







# INSTALLATION OPERATION AND SERVICE MANUAL

  	<p><b>GAS FIRED RESIDENTIAL AND COMMERCIAL STAINLESS STEEL TANK HEATERS</b></p> <p><b>TH SERIES</b></p> <p><b>HOT WATER SUPPLY</b></p> <p><i>Models; TH082 ,102, 152, 202, 252, 292, 392, 502</i></p>	  
---	---	---

**WARNING:**

If the information in these instructions is not followed exactly, a fire or explosion may result causing property damage, personal injury or death

Do not store or use gasoline or other flammable vapours and liquids in the vicinity of this or any other appliance.

**WHAT TO DO IF YOU SMELL GAS**

- o Do not try to light any appliance,
- o Do not touch any electrical switch; do not use any phone in your building,
- o Immediately call your gas supplier from a neighbour's phone. Follow the gas supplier's instructions,
- o If you cannot reach your gas supplier, call the fire department.

**Qualified installer, service agency or the gas supplier must perform installation and service.**

**To the Installer:** After installation, these instructions must be given to the end user or left on or near the appliance.

**To the End User:** This booklet contains important information about this appliance. Retain for future reference.



**CAMUS HYDRONICS LTD.**

6226 Netherhart Road, Mississauga, Ontario, L5T 1B7

99-0079  
Rev. 0.1



## **TABLE OF CONTENTS**

PART 1	GENERAL INFORMATION.....	1
1.1	INTRODUCTION.....	1
1.2	SPECIAL INSTRUCTIONS TO OWNER.....	1
1.3	CHECKING EQUIPMENT.....	1
1.4	DISPLAY UNIT.....	1
1.5	SEQUENCE OF OPERATION.....	1
1.5.2	Heat Transfer Process.....	2
1.5.3	End of Sequence.....	2
1.6	INSTALLATION CODES.....	2
1.7	WARRANTY.....	2
1.8	REMOVAL OF EXISTING APPLIANCE.....	3
1.9	BOILER/FURNACE ROOM OPERATING CONDITION.....	3
1.10	LOCATION OF UNIT.....	3
1.11	CLEARANCE FROM COMBUSTIBLE MATERIAL.....	4
PART 2	AIR INLET AND VENTING.....	7
2.1	GENERAL VENTING GUIDE.....	7
2.2	CATEGORY IV VENTING (TH 082 – 502).....	7
2.2.1	Approved Venting Materials Category IV.....	8
2.3	CATEGORY II VENTING (TH 202 - 502).....	8
2.3.1	Approved Venting Materials Category II.....	8
2.4	COMBINED COMBUSTION AIR INLET.....	8
2.5	VENT TERMINATION AND AIR INLET CLEARANCES.....	9
2.5.1	Sidewall Venting.....	9
2.5.2	Sidewall Air Inlet.....	9
2.5.3	Sidewall Concentric Vent/ Air.....	10
2.6	Vertical Direct Venting.....	10
PART 3	GAS CONNECTION.....	12
3.1	GAS CONNECTION.....	12
3.2	GAS PIPING.....	12
3.3	INSTALL PIPING.....	12
3.4	CHECKING GAS SUPPLY PRESSURE.....	12
3.5	HIGH and LOW GAS PRESSURE SWITCHES (Optional).....	13
3.6	AIR/GAS RATIO VALVE.....	13
3.7	BURNER.....	13
PART 4	WATER CONNECTION.....	14
4.1	INLET AND OUTLET CONNECTIONS.....	14
4.2	MINIMUM PIPE SIZE REQUIREMENTS.....	14
4.3	HEAT EXCHANGER.....	14
4.4	LOW WATER TEMPERATURE SYSTEMS.....	14
4.5	PIPING ARRANGEMENTS.....	14
4.5.1	Field Supplied Components.....	14
4.6	FLOW PROVING DEVICE.....	15
4.7	T&P RELIEF VALVE.....	15
4.8	STAINLESS STEEL STORAGE TANK.....	15
PART 5	ELECTRICAL & CONTROLS.....	15
5.1	ELECTRICAL CONECTIONS.....	15
5.2	HIGH LIMIT.....	15
5.3	TH CONTROLLER.....	15
5.3.1	Service Parts.....	16
5.3.2	Ignition Module Lockout Functions.....	16
5.4	ERROR TABLE.....	16

5.4.1	Lockout Codes.....	16
5.4.2	Alert Codes .....	16
PART 6	CONTROL PANEL.....	17
6.1	TH CONTROLLER.....	17
6.2	SETTING THE TH CONTROLLER.....	17
6.3	DOMESTIC HOT WATER OPERATION.....	17
PART 7	COMPONENTS .....	17
7.1	DIRECT SPARK IGNITER.....	17
7.2	FLAME SENSOR.....	17
7.3	COMBUSTION AIR FAN .....	18
7.4	GAS VALVE .....	18
7.5	OUTER JACKET.....	18
PART 8	TH CONTROL PANEL.....	19
8.1	INTRODUCTION TO THE TH CONTROL PANEL.....	20
8.2	USER MODE.....	21
8.3	SETUP MODE.....	22
8.4	DIAGNOSTIC MODE .....	23
PART 9	TROUBLESHOOTING.....	25
9.1	SETTING THE CORRECT COMBUSTION.....	28
9.2	GAS VALVE ADJUSTMENT PROCEDURE .....	28
PART 10	MAINTENANCE .....	30
10.1	EXAMINE THE VENTING SYSTEM .....	30
10.2	VISUALLY CHECK MAIN BURNER FLAMES .....	30
10.3	CLEANING BOILER HEAT EXCHANGER .....	30
10.4	CONDENSATE TREATMENT .....	31
10.4.1	Condensate Volume.....	31
10.5	IGNITER AND FLAME SENSOR ELECTRODES.....	31
10.6	CHECK IGNITER GROUND WIRING.....	31
10.7	BURNER MAINTENANCE .....	31
10.7.1	Burner Removal and Cleaning .....	31
10.8	REMOVAL OF COMBUSTION CHAMBER LINING.....	32
10.9	COMBUSTION AND VENTILATION AIR.....	32
10.10	CONTROL CIRCUIT VOLTAGE.....	32
10.11	COMBUSTIBLE MATERIALS.....	32
10.12	FREEZE PROTECTION FOR INDOOR & OUTDOOR INSTALLATIONS .....	32
PART 11	INSTALLATIONS.....	33
11.1	CHECKING THE INSTALLATION .....	33
11.2	CHECKING THE CONSTRUCTION.....	33
11.3	INSPECT & RECHARGE CONDENSATE COLLECTION/NEUTRALIZING RESERVOIR .....	33
11.4	WATER CONNECTIONS .....	33
11.5	SUMMARY.....	33
11.6	TEMPERATURE RISE AT FULL FIRING RATE .....	34
11.7	SETTING THE CORRECT COMBUSTION.....	34
11.8	APPLIANCE .....	34
11.9	IGNITION CYCLE.....	35
PART 12	SUGGESTED PIPING DIAGRAMS.....	36
PART 13	EXPLODED VIEW & PARTS LIST .....	37
PART 14	ELECTRICAL DIAGRAMS.....	41
14.1	TH 82- 502 INTERNALWIRING DIAGRAM .....	41
14.2	DETAILED CONNECTOR DESCRIPTION .....	42



# PART 1 GENERAL INFORMATION

## 1.1 INTRODUCTION

The **TH Series** is a fan assisted heater based on a push through design which offers several venting options. Heat output is controlled by a one to one air/gas ratio control gas valve which provides seamless modulation. The heater provides domestic hot water at working pressures up to 160 PSI. It is designed for use with a fully pumped and pressurized water system. The water heater will automatically modulate to provide heat outputs from 100% down to approximately 20% of rated input.

The TH utilizes a negative pressure gas valve. The operation of the fan will generate a negative pressure in the venturi, which draws in a matching amount of gas through the valve.

During operation the TH maintains a steady state efficiency across the entire range of modulation. Air and gas are metered in precise proportion (1:1 Ratio) allowing combustion characteristics which determine efficiency to remain the same over the entire operating range.

The TH is designed so that all of the sensible heating value and most of the latent heat is being transferred to the water.

## 1.2 SPECIAL INSTRUCTIONS TO OWNER

This manual supplies information for the installation, operation and servicing of the appliance. It is strongly recommended that this manual be reviewed completely before proceeding with an installation

### CAUTION

It is important that all gas appliances are installed by a qualified installer/technician that is trained by Camus Hydronics. It is in your own interest and that of safety to ensure that all local codes, and all the following "NOTES" and "WARNINGS" are complied with. Installing, servicing or adjusting this appliance should be performed only by a qualified installer/technician that is trained by Camus Hydronics. The serviceman must utilize a combustion analyzer with CO<sub>2</sub>, CO to set the appliance according to Camus Hydronics' recommendations, prior to commissioning.

### NOTE

RETAIN THIS MANUAL FOR FUTURE REFERENCE

## 1.3 CHECKING EQUIPMENT

Check for signs of shipping damage upon receiving equipment. Pay particular attention to parts accompanying the boiler, which may show signs of being hit or otherwise being mishandled. Verify total number of pieces shown on packing slip with those actually received. In case there is damage or a shortage, immediately notify carrier.

## 1.4 DISPLAY UNIT

The display unit will indicate status and will display selected temperature. Refer to Part 8 TH Control Panel, which provides details to modes and error codes displayed on the appliance.

## 1.5 SEQUENCE OF OPERATION

- 1) The power switch is placed in the "ON" position.
- 2) Minimum 120 VAC 60Hz single phase (15A circuit) is supplied to the Terminal Strip.
- 3) 24 VAC power is supplied to the TH Controller which provides all setup and ignition control functions.
- 4) A heat request is detected by the DHW Sensor.
- 5) After the appliance water pump starts, flow is proven by the flow proving device.
- 6) The TH Controller initiates a start-up sequence once it receives a heat demand.
- 7) Voltage is sent to the electrically commutated DC motor of the combustion fan after the internal safety checks are satisfied.
- 8) The fan will run at Pre-Purge speed until the Pre-Purge timer is satisfied. Once this is complete the TH Controller provides a signal to modulate down to ignition fan speed.
- 9) The TH Controller supplies voltage to the air/gas ratio control valve. The air/gas ratio control valve senses the pressure across the venturi and supplies gas to pre-mix with air.
- 10) The igniter will continue to spark for 6 seconds, with the gas valve opened 2 seconds after the initial spark is generated with the fan running at ignition speed.
- 11) Spark igniter lights the air/gas mixture. The TH Controller looks for a minimum flame rectification signal of 0.8  $\mu$ A DC from the flame sensor during the Main Flame Establishing Period. If the signal is present the TH Controller will allow the gas valve to remain open. The burner is now firing at starting input rate.
- 12) The fan is kept at ignition speed until the stabilization timer is satisfied.
- 13) The boiler will modulate to the correct fan speed to meet the heat demand. The modulation rate is controlled via Pulse Width Modulation (PWM) signals provided by the TH Controller.
- 14) The fan speed will slowly decrease as the heat request nears the heat demand. If the heat demand is sustained for a long duration of time the boiler will get to a point of steady-state and the fan will rotate at a constant speed.
- 15) When the heat demand is satisfied or is removed the burner will shut off and the fan speed will ramp up to the preset Post-Purge speed until the Post-Purge Timer is satisfied.
- 16) The pump continues to circulate until the post-pump time is satisfied.
- 17) The boiler will then go into Standby as it waits for the next heat demand.

Figure 1: TH Ignition Cycle

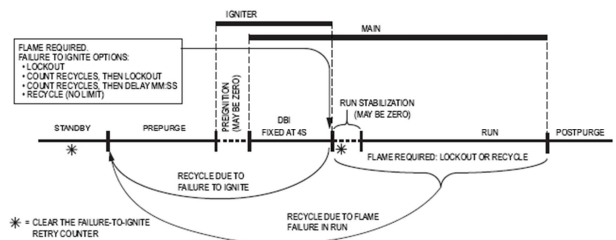

Note:

1. If a flame signal is detected at the end of the pre-purge period a lockout will occur.
2. If at the end of the safety period (6 sec) no flame is detected the control will go to post-purge to remove the unburned gas. After this, a re-ignition attempt is started following the same cycle. The number of re-ignition attempts is limited to 2 after which a lockout occurs.
3. The burner can only be on continuously for a period of 24 hours. After this the burner is switched off and a restart sequence follows.
4. Sparking stops 2 seconds before the end of the ignition period to allow for ionisation detection.

### 1.5.2 Heat Transfer Process

- 1) Burner input continues to increase until DHW water temperature reaches the setpoint temperature.
- 2) Burner input may stabilize at a fixed rate where demand equals input.
- 3) Burner input will decrease when DHW water temperature approaches temperature setpoint.

### 1.5.3 End of Sequence

- 1) Setpoint temperature is satisfied.
- 2) Power to the gas valve is turned off.
- 3) Combustion air fan ramps to a stop over the factory preprogrammed time period.

WARNING
To minimize the possibility of serious personal injury, fire or damage to your appliance, never violate the following safety rules.

DO NOT
Do not use this appliance if any part of it has been <b>under water</b> . The possible damage to a flooded appliance can be extensive and present numerous safety hazards. Any appliance that has been <b>under water</b> must be replaced

WHAT TO DO IF YOU SMELL GAS
Do not try to light any appliance. • Do not touch any electric switch: do not use any phone in your building. • Immediately call your gas supplier from a neighbor's phone. Follow the gas supplier's instructions. • If you cannot reach your gas supplier, call the fire department.

IMPORTANT
Consult and follow local Building and Fire Regulations and other Safety Codes that apply to this installation. Contact the local gas utility company to inspect and authorize all gas and flue connections.
<b>Installation and service must be performed by a qualified technician/installer, and trained by Camus Hydronics.</b>

WARNING
Should overheating occur or the gas supply fails to shut off, <b>DO NOT</b> turn off or disconnect the electrical supply to the pump. Shut off the gas supply at a location external to the appliance.

- Boilers and water heaters are heat producing appliances. To avoid damage or injury, do not store materials against the appliance or the vent-air inlet system. Use proper care to avoid unnecessary contact (especially children) with the appliance and vent-air inlet components.
- Never cover appliance, lean anything against it, store trash or debris near it, stand on it or in any way block the flow of fresh air to appliance.
- **UNDER NO CIRCUMSTANCES** may flammable materials such as gasoline or paint thinner be used or stored in the vicinity of this appliance, vent-air inlet system or any location from which fumes could reach the appliance or vent-air inlet system.
- A gas appliance that draws combustion air from the equipment room where it is installed must have a supply of fresh air circulating around it during burner operation for proper gas combustion and proper venting.

## 1.6 INSTALLATION CODES

The equipment shall be installed in accordance with those installation regulations enforced in the local area where the installation is to be made. These shall be carefully followed in all cases. Authorities having jurisdiction shall be consulted before installations are made. In the absence of such requirements, the installation shall conform to the latest edition or current as amended of the National Fuel Gas Code, ANSI Z223.1 and/or CAN/CGA-B149 Installation Code. All electrical wiring must be done in accordance with the requirements of the authority having jurisdiction or, in the absence of such requirements, with national electrical code, ANSI/NFPA70 and/or the Canadian electrical code part 1 CSA C22.1. Where required by the authority having jurisdiction, the installation must conform to American Society of Mechanical Engineers Safety Code for Controls and Safety Devices for Automatically Fired Boilers, ASME CSD-1. All boilers must conform to the latest edition of the ASME Boiler and Pressure Vessel Code, Section II. Where required by the authority having jurisdiction, the installation must comply with the CSA International, CAN/CGA-B149 and/or local codes. This appliance meets the safe lighting performance criteria with the gas manifold and control assembly provided, as specified in the ANSI standards for gas-fired units, ANSI Z21.10.3b-2008.

## 1.7 WARRANTY

- Factory warranty (shipped with unit) does not apply to units improperly installed or improperly operated.
- Factory warranty shall apply only when the appliance is installed in accordance with local plumbing and building codes, ordinances and regulations, the printed instructions provided with it and good industry practices.
- Excessive **water hardness** causing a lime build-up in the stainless steel coils or tubes is not a fault of the appliance and is not covered by warranty. Consult the factory for recommendations for use in hard water areas. (See Water Treatment and Water Chemistry)
- Using or storing **corrosive chemicals** in the vicinity of this appliance will attack the stainless steel jacket, the stainless steel venting, heat exchanger coils, wiring and brass fittings and voids warranty.

- Damage caused by **freezing or dry firing** voids warranty.
- This appliance is not to be used for **temporary heating** of buildings under construction.
- The manufacturer shall **NOT** be held liable for any personal injury or property damage due to ice formation or the dislodging of ice from the vent system or the vent termination

### 1.8 REMOVAL OF EXISTING APPLIANCE

When an existing appliance is removed from a common venting system, the common venting system is likely to be too large for proper venting of the appliances remaining connected to it .At the time of removal of an existing appliance, the following steps must be followed with each appliance remaining connected to the common venting system placed in operation, while the other appliances remaining connected to the common venting system are not in operation.

- Seal any unused openings in the common venting system.
- Visually inspect the venting system for proper size and horizontal pitch and determine that there is no blockage, restriction, leakage, corrosion or other deficiency, which could cause an unsafe condition.
- Insofar as is practical, close all building doors and windows and all doors between the spaces in which the appliances remaining connected to the common venting system are located and other spaces of the building. If applicable turn on the clothes dryers and any appliances not connected to the common venting system. Turn on any exhaust fans, such as range hoods and bathroom exhausts, so they will operate at maximum speed. Do not operate a summer exhaust fan. Close fireplace dampers.
- Place in operation the appliance being inspected. Follow the lighting instructions. Adjust thermostat so that appliance operates continuously.
- Test for spillage at the draft control device relief opening after 5 minutes of main burner operation.
- After it has been determined that each appliance remaining connected to the common venting system properly vents when tested as outlined above, return doors, windows, exhaust fans, fireplace dampers and any other gas-burning appliance to their previous condition of use.
- Any improper operation of the common venting system should be corrected so that the installation conforms to the National Fuel Gas Code, ANSI Z223.1 and/or CAN/CGA B149, Installation Codes. When resizing any portion of the common venting system, the common venting system should be resized to approach the minimum size as determined using the appropriate tables in Part 11 of the National Fuel Gas Code, ANSI Z223.1 and /or CAN/CGA B149, Installation Codes.

Heat exchanger surfaces and vent piping should be checked every six months for deterioration and carbon deposits. Remove all soot or other obstructions from the chimney and flue, which might impede draft action. Replace any damaged or deteriorated parts of the venting system.

A qualified service technician should follow this procedure

when inspecting and cleaning the heat exchanger and vent pipe.

- 1) Turn off electrical power and main manual gas shut-off and allow appliance to cool down.
- 2) Remove the vent pipe at connection to heat exchanger and check heat exchanger and vent for obstruction and clean as necessary.
- 3) Remove burner from appliance and carefully clean as required. Never brush or wipe the knitted metal fiber surface. Use a garden hose or gently wash under the tap. Vacuum out any deposits found in the heat exchanger.

#### CAUTION

Never use a pressure washer or compressed air to clean the burner.

- 4) Reinstall parts removed in steps 2 and 3. Be sure that vent pipe has proper pitch and is properly sealed. Replace any damaged gasket or refractory. Tighten fan flange mounting nuts to 3 ft-lb.
- 5) Restore electrical power and gas supply to appliance.
- 6) Place appliance in operation using lighting instructions provided.
- 7) Confirm proper operation of all safety devices
- 8) Check for gas leaks and proper vent operation.

#### NOTE

**Experience has shown that improper installation or system design, rather than faulty equipment, is the cause of most operating problems**

### 1.9 BOILER/FURNACE ROOM OPERATING CONDITION

- Due to low jacket losses from the appliance, temperatures in the vicinity of the boiler room may drop significantly; supplemental heat is required to maintain ambient temperature at minimum of 40°F.

### 1.10 LOCATION OF UNIT

Install this appliance in a clean, dry location with adequate service clearance.

- Do not locate this appliance in an area where it will be subject to freezing unless precautions are taken. Radiant losses from the TH are minimal and should not be relied on to keep the appliance room warm.
- The appliance should be located close to a floor drain in an area where leakage from the appliance or connections will not result in damage to the adjacent area or to lower floors in the structure, it is recommended that a suitable drain pan, adequately drained, be installed under the unit. Under no circumstances is the manufacturer to be held responsible for water damage in connection with this unit, or any of its components.
- If the appliance is installed above the level of the building's radiation system, a low water cut-off device must be installed in the appliance outlet at a minimum of 3 ft (1M) above the heat exchanger inlet/outlet connections. Some local codes require the installation of a low water cut-off on all systems
- When placing the appliance beware that a minimum clearance of 24" must be provided at the front to allow easy access to the heat exchanger.
- The appliance must be installed so that the ignition system components are protected from water

(dripping, spraying, etc.) during appliance operation and service (circulator replacement, control replacement, etc.)

- Appliances located in a residential garage and in adjacent spaces that open to the garage and are not part of the living space of a dwelling unit must be installed so that all burners and burner ignition devices have a minimum clearance of not less than 18" (46cm) above the floor. The appliance must be located or protected so that it is not subject to physical damage by a moving vehicle.
- **DO NOT** install this appliance in any location where gasoline or flammable vapors are likely to be present.
- Appliance must be installed on a level floor. Maintain required clearances from combustible surfaces.
- The appliance designed for indoor installation (Indoor Models) must be installed indoors where it is protected from exposure to wind, rain and weather.
- The appliance designed for outdoor installation (Outdoor Models) must be installed outdoors. For outdoor installations, always consider the use of a shelter such as a garden shed in lieu of direct exposure of the appliance to the elements. The additional protection afforded by the shelter will help to minimize nuisance problems with electrical connections and will allow easier servicing of the appliance under severe weather conditions.

### 1.11 CLEARANCE FROM COMBUSTIBLE MATERIAL

This appliance is suitable for alcove (a closet without a door) installation with minimum clearances to combustibles as follows:

**Table 2: Clearance from Combustibles**

Clearances from Combustibles	
TOP:	0"
SIDES:	0"
REAR:	12"
VENT (Vent Adapter/ Stainless Steel):	1"
VENT (PVC/CPVC):	0"
FRONT:	6"

**Figure 1: TH Clearance from Combustibles**

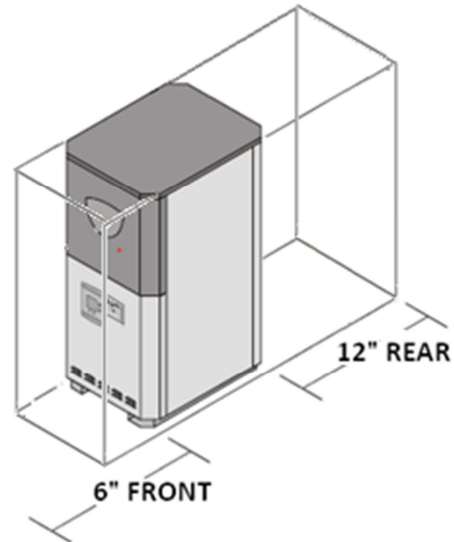

**NOTE**

Clearances from combustible construction are noted on the appliance rating plate

**Table 3: TH Service Clearances**

Input [BTU/hr]	Service Clearance, Inches (cm)				
	Front	Top	Right Side	Left Side	Rear
80,000	24" (61cm)	18" (46cm)	0" (0cm)	24" (61cm)	12" (31 cm)
100,000	24" (61cm)	18" (46cm)	0" (0cm)	24" (61cm)	12" (31 cm)
150,000	24" (61cm)	18" (46cm)	0" (0cm)	24" (61 cm)	12" (31cm)
199,000	24" (61cm)	18" (46cm)	0" (0cm)	24" (61 cm)	12" (31 cm)
250,000	24" (61cm)	18" (46cm)	0" (0cm)	24" (61 cm)	12" (31 cm)
299,000	24" (61cm)	18" (46cm)	0" (0cm)	24" (61 cm)	12" (31cm)
399,000	24" (61cm)	18" (46cm)	0" (0cm)	24" (61 cm)	12" (31 cm)
500,000	24" (61cm)	18" (46cm)	0" (0cm)	24" (61 cm)	12" (31 cm)

**Figure 2: TH Model Dimensions**

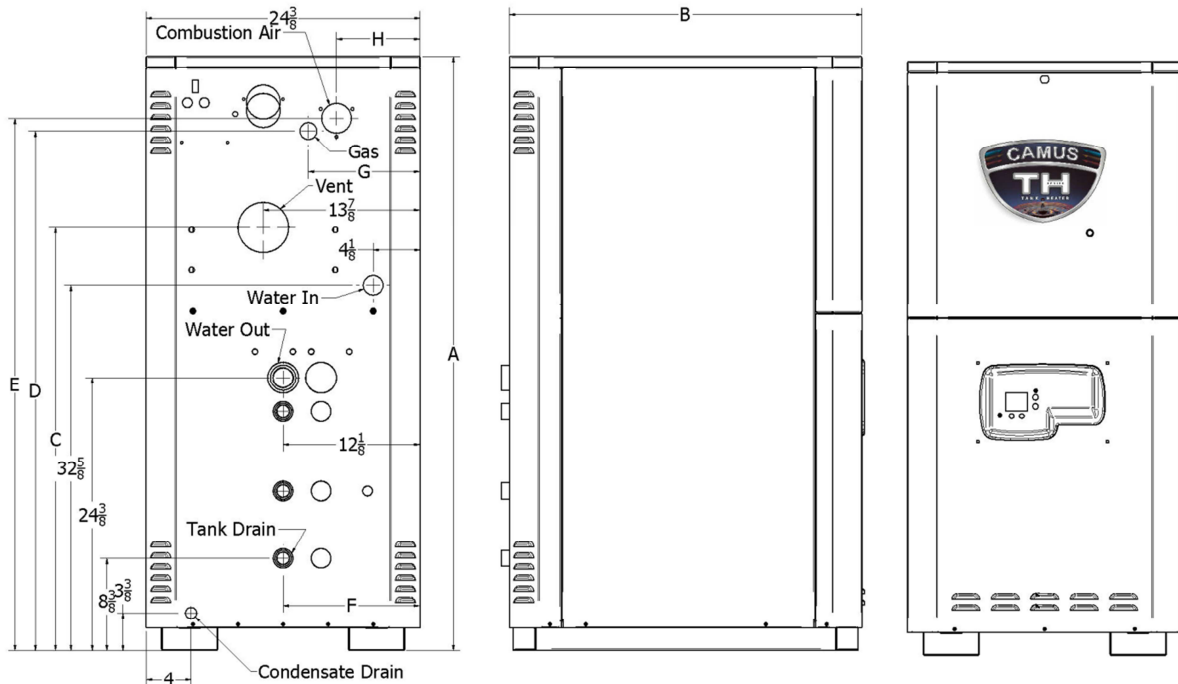
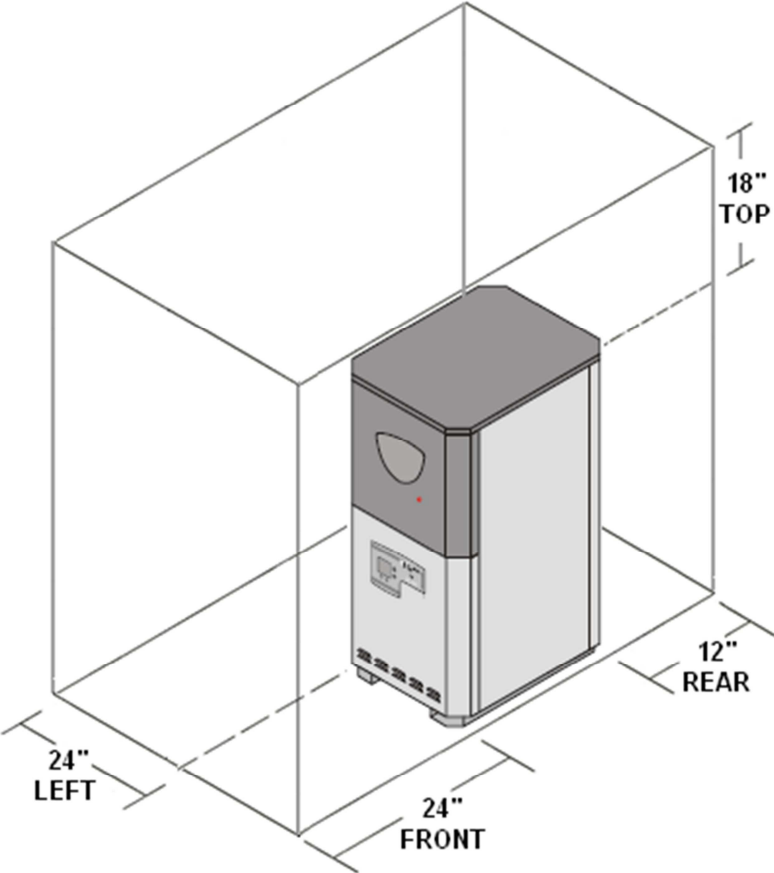

**Table 4: Appliance Dimensions and Specifications**

Input [BTU/hr]	Dim. "A" [in.]	Dim. "B" [in.]	Dim. "C" [in.]	Dim. "D" [in.]	Dim. "E" [in.]	Dim. "F" [in.]	Dim. "G" [in.]	Dim. "H" [in.]	Equivalent Length of Vent & Air Intake Pipes at Recommended Diameter, [in.]				Water Conn. at Boiler [in.] NPT	Gas Conn. at Boiler [in.] NPT
									Category IV			CAT.II Comb. Vents		
									Over 25' and up to 100'	Over 15' and up to 25'	Up to 15'			
80,000	53	22 1/4	46 1/4	46 3/8	47 1/2	8 3/4	9 7/8	7 3/8	3	3	2	-	1	1/2
100,000	53	22 1/4	46 1/4	46 3/8	47 1/2	8 3/4	9 7/8	7 3/8	3	3	2	-	1	1/2
150,000	53	22 1/4	46 1/4	46 3/8	47 1/2	8 3/4	9 7/8	7 3/8	3	3	2	-	1	1/2
199,000	53	31 1/4	37 3/4	46 3/8	47 1/2	12 1/8	9 7/8	7 3/8	3	3	2	4	1	1/2
250,000	53	31 1/4	37 3/4	46 3/8	47 1/2	12 1/8	9 7/8	7 3/8	3	3	2	4	1 1/4	1/2
299,000	65 1/2	31 1/4	37 1/2	58 3/8	53 7/8	12 1/8	11 3/8	8 7/8	4	3	3	5	1 1/4	3/4
399,000	65 1/2	31 1/4	37 1/2	58 3/8	53 7/8	12 1/8	11 3/8	8 7/8	4	3	3	5	1 1/2	1
500,000	65 1/2	31 1/4	37 1/2	58 3/8	53 7/8	12 1/8	11 3/8	8 7/8	4	3	3	6	1 1/2	1

Maintain minimum specified clearances for adequate operation. All installations must allow sufficient space for servicing the vent connections, water pipe connections, circulating pump, bypass piping and other auxiliary equipment, as well as the appliance

**Figure 3: TH Service Clearances**





## PART 2 AIR INLET AND VENTING

### **⚠ DANGER**

It is extremely important to follow these venting instructions carefully. Failure to do so can cause severe personal injury, death or substantial property damage.

### 2.1 GENERAL VENTING GUIDE

- Single pipe vent with common air from room.

Figure 4: Venting Configuration

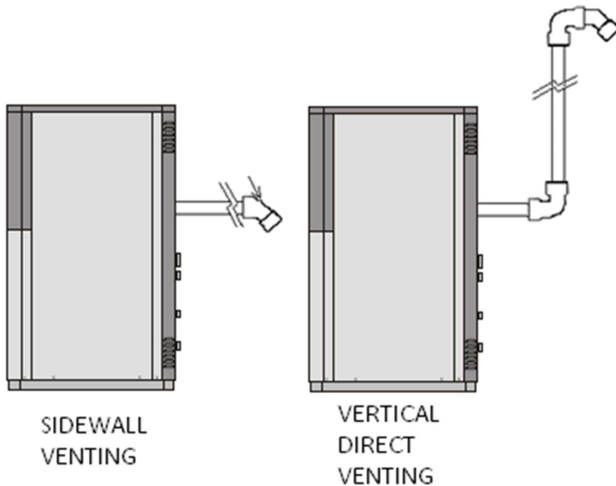

The TH is a category II/IV condensing appliance, 97% efficient unit.

The TH may be vented with manufactured prefabricated UL/ULC listed vents of AL29-4C or 316L stainless steel or with plastic vent certified to UL/ULC S636, such as, IPEX System 636 CPVC or IPEX System 636 PVC or as permitted by local jurisdictions.

- The TH must be vented and supplied with combustion and ventilation air as described in this section. Ensure that the venting and combustion air supply complies with these instructions regarding the vent system, air system, and combustion air quality.
- Installations must be in accordance with Part 7, "Venting of Equipment", of the latest edition of the National Fuel Gas Code, ANSI Z223.1 for US installations or the latest edition of CAN/CGA Standard B149 Installation Code for Gas Burning Appliances and Equipment in Canada.
- The distance of the vent terminal from adjacent buildings, windows that open and building openings MUST comply with the latest edition of the National Fuel Gas Code, ANSI Z223.1 for U.S. installations or CAN/CGA Standard B149 Installation Code for Canadian Installations.
- Vent connection is made directly to the flue outlet opening on the rear of the unit. The connection from the appliance vent to the stack must be made as direct as possible. The first 3 feet of vent from the appliance flue outlet must be readily accessible for visual inspection.
- Vent connectors serving appliances vented by natural draft shall not be connected into any portion of a mechanical draft system operating under positive pressure.

- A UL listed concentric vent/air intake kit may be used with the TH.
- Horizontal runs of vent pipe shall be securely supported (approximately every 4 feet) to prevent sagging and maintain a minimum upward slope of 1/4" per foot from the appliance to the vent terminal.
- The weight of the venting system must not rest on the unit. Adequate support of the venting system must be provided in compliance with local codes and other applicable codes.
- All connections should be secured and sealed per the vent manufacturer's specifications. When a positive vent system is disconnected for any reason, the flue must be reassembled and resealed according to the vent manufacturer's instructions.
- Do not use an existing chimney as a raceway if another appliance or fireplace is vented through the chimney.
- Inspect completed vent and air supply piping thoroughly to ensure all connections are sealed and are in compliance with the instructions provided and satisfy requirements of all applicable codes.

#### NOTE

All vent pipes must be properly assembled and supported, and the exhaust must be pitched a minimum of 1/4 inch per foot back to the boiler. All components used to fabricate and assemble the vent system are to originate from the same supplier.

When determining equivalent inlet air and vent lengths of 3" diameter add 3 to 5 feet for each 90° elbow and 2 to 3 feet for each 45° elbow, depending on centerline radius of the elbow.

Example: 30 feet of CPVC pipe + (3 x 5 feet) 90° elbows + (1 x 3 feet) 45° elbow = 48 equivalent feet of piping for centerline radius of 1.5D, where D is the pipe diameter.

### 2.2 CATEGORY IV VENTING (TH 082 – 502)

A category IV appliance is individually vented through a dedicated vent.

The TH shall be vented as a Category II/ IV condensing appliance as per table 4.

The appliance shall be vented using sealed positive vent suitable for a condensing appliance with the following venting options:

- 1) Sidewall or rooftop termination where both the vent and combustion air inlet air are in the same zone. The inlet and vent terminals are to be installed with a minimum 12" separation distance between centerline of inlet and centerline of exhaust. Refer to Fig. 5, 6, and 7 for sidewall termination and Fig. 8 for rooftop termination.
- 2) Sidewall termination with vent and combustion air inlet from separate zones.
- 3) Single Pipe thru wall or rooftop venting with combustion air inlet from the boiler room.

#### NOTE

Vent Option 3 not recommended for R-2000 homes or equivalent air tight construction.

**2.2.1 Approved Venting Materials Category IV**

- 1) PVC and CPVC (Chlorinated Polyvinyl Chloride) Schedule 40 or 80 approved to ULC S636.
- 2) Manufactured prefabricated UL/ULC listed vent of AL29-4C or 316L stainless steel. Use of 316L is limited to use in applications where there is no possibility of contaminants in the air such as refrigerants, chlorine etc.
- 3) PVC-DWV approved to comply with ANSI/ASTM D2665 (US Jurisdictions ONLY when permitted)
- 4) PVC Schedule 40 approved to comply with ANSI/ASTM D1785. (US Jurisdictions ONLY when permitted)
- 5) CPVC Schedule 40 approved to comply with ANSI/ASTM F441. (US Jurisdictions ONLY when permitted)
- 6) Polypropylene approved to comply with ULC S636

**Table 5: Maximum Flue Temperature for Various Vent Materials**

Vent Material	Maximum Flue Temperature [°F]
PVC	149
CPVC	194
PPE	230
AL29-4C	300+, limited only by rating of seals
316L Stainless Steel	300+, limited only by rating of seals

**Air Inlet (Supply Air or Fresh Air) Piping**

- PVC
- CPVC (Chlorinated Polyvinyl Chloride)
- ABS (Acrylonitrile-Butadiene-Styrene)
- PPE (Polypropylene)
- Single wall, Galvanized
- Single wall, Stainless steel
- Single wall, Aluminum

Single wall air inlet pipes are to be insulated 5 feet from the wall toward the interior of the building to minimize external sweating.

The following air intake options shall be utilized:

- Outside air sealed direct (vertical or horizontal)
- Outside air ducted to jacket flange
- Indoor Air

**Table 6: Required Vent and Air Inlet Diameters**

Input [BTU/hr]	Equivalent Length of Vent & Air Intake Pipes at Recommended Diameter*			
	Category IV			Category II
	Over 25' and up to 100'	Over 15' and up to 25'	Up to 15'	
80,000	3"	2"	2"	-
100,000	3"	2"	2"	-
150,000	3"	2"	2"	-
199,000	3"	3"	2"	4"
250,000	3"	3"	2"	4"
299,000	4"	3"	3"	5"
399,000	4"	3"	3"	5"
500,000	4"	3"	3"	6"

\* Consult factory for recommendations applicable to venting combinations not shown above.

**2.3 CATEGORY II VENTING (TH 202 - 502)**

A category II appliance may be combined into a common negative pressure venting system designed to ASHRAE requirements using a proven vent sizing program. Vent designs are to be certified by a qualified professional designer acceptable to the authority having jurisdiction.

The TH may be vented as a Category II appliance using sealed vent suitable for a condensing appliance.

**2.3.1 Approved Venting Materials Category II**

- 1) PVC and CPVC (Chlorinated Polyvinyl Chloride) Schedule 40 or 80 approved to ULC S636.
- 2) Manufactured prefabricated UL/ULC listed vent of AL29-4C or 316L stainless steel. Use of 316L is limited to use in where there is no possibility of contaminants in the air such as refrigerants, chlorine etc.
- 3) PVC-DWV approved to comply with ANSI/ASTM D2665 (US Jurisdictions ONLY when permitted).
- 4) PVC Schedule 40 approved to comply with ANSI/ASTM D1785. (US Jurisdictions ONLY when permitted)
- 5) CPVC Schedule 40 approved to comply with ANSI/ASTM F441. (US Jurisdictions ONLY when permitted).
- 6) Polypropylene approved to comply with ULC S636

**Air Inlet (Supply Air or Fresh Air) Piping**

- PVC
- CPVC (Chlorinated Polyvinyl Chloride)
- ABS (Acrylonitrile-Butadiene-Styrene)
- PPE (Polypropylene)
- Single wall, Galvanized
- Single wall, Stainless steel
- Single wall, Aluminum

Single wall air inlet pipes are to be insulated 5 feet from the wall toward the interior of the building to minimize external sweating.

The following air intake options shall be utilized:

- Outside air sealed direct (vertical or horizontal)
- Outside air ducted to jacket flange
- Indoor Air

**NOTE**

Sealed combustion is required when the TH is placed in a space with other fan-assisted appliances.

**2.4 COMBINED COMBUSTION AIR INLET**

The TH may be installed with a combined combustion air inlet.

The combined combustion air inlet pipe sizing can be calculated using the method shown below:

Equivalent pipe diameter = Sq Root [(d<sub>1</sub>)<sup>2</sup> + (d<sub>2</sub>)<sup>2</sup> + (d<sub>3</sub>)<sup>2</sup> + ... + (d<sub>n</sub>)<sup>2</sup>], where d<sub>n</sub> = individual pipe diameter

- Example: Find the equivalent pipe diameter of three air inlet pipes, 3" (7.6cm), 3" (7.6cm) and 4" (10.2cm)

Equivalent pipe diameter = Sq Root[(3)<sup>2</sup> + (3)<sup>2</sup> + (4)<sup>2</sup>] = Sq Root(34) = 5.8", select 6" (15.3cm) equivalent diameter pipe.



The air inlet point for multiple air inlets must be provided with an exterior opening which has a free area equal to or greater than the total area of all air inlet pipes connected to the common air inlet. This exterior opening for combustion air must connect directly to the outdoors. The total length of the combined air inlet pipe must not exceed a maximum of 100 equivalent feet (30.5m). Deduct the restriction in an area provided by any screens, grills or louvers installed in the common air inlet point. Screens, grills or louvers installed in the common air inlet can reduce the free area of the opening from 25 to 75% based on the materials used. Calculate and compensate accordingly.

## 2.5 VENT TERMINATION AND AIR INLET CLEARANCES

### 2.5.1 Sidewall Venting

- The first 3 feet (1m) of vent from the appliance flue outlet must be readily accessible for inspection.

Figure 5: Sidewall Vertical Configuration

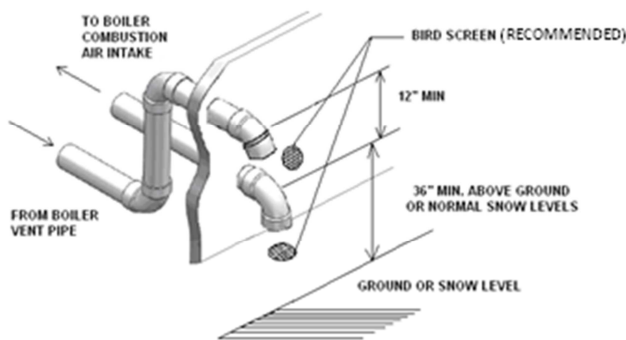

- \* Always check local codes for minimum distance above ground or snow levels

Figure 6: Sidewall Horizontal Configuration

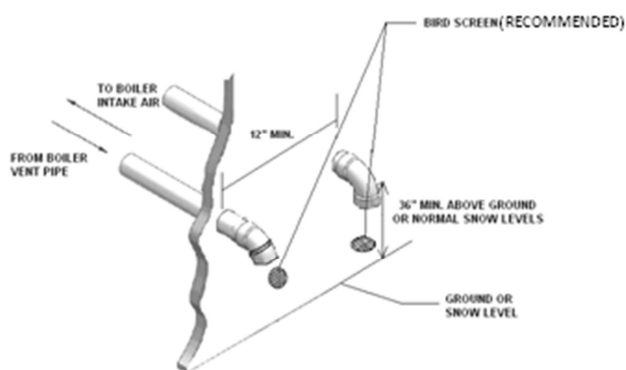

- \* Always check local codes for minimum distance above ground or snow levels

### Location of Vent Termination

- The total length of vent piping must not exceed the limits stated in Table 6.
- The bottom of the vent terminal shall be located at least 3 feet (1m) above grade or above normal snow levels. In all cases the appliance shall be installed in accordance with local codes
- The TH can vent up to 100 equivalent feet. Elbows can range from 3 to 5 feet in equivalent length depending on the centerline radius. Vent sizes are

3" for Models 82 to 252 and 4" for Models 292 to 502 for equivalent vent lengths of up to 100'.

- The vent outlet shall terminate at least 12" (0.30m) away from any forced air inlet. The vent must be at least 7 feet (2.15m) above grade when located adjacent to public walkways due to normal formation of water vapour in the combustion process.
- The vent outlet MUST NOT terminate below a forced air inlet at any distance
- The vent cannot terminate below grade. Position the vent termination where vapours will not damage walls or plants or may be otherwise objectionable.
- The vent terminal shall not be installed closer than 3 feet (1m) from an inside corner of an L-shaped structure, window well, stairwell, alcove, courtyard or other recessed area as wind eddies could affect boiler performance or cause recirculation.
- DO NOT terminate closer than 4 feet (1.25m) horizontally and vertically from any electric meter, gas meter, regulator, relief valve, or other equipment. In all cases local codes take precedence
- Position terminations so they are not likely to be damaged by foreign objects, or exposed to a build-up of debris.
- The vent piping must terminate in an elbow pointed outward or away from the air inlet.
- Flue gas condensate can freeze on exterior walls or on the vent cap. Frozen condensate on the vent cap can result in a blocked flue condition. Keep the vent cap/terminal clear of snow, ice, leaves, debris etc. Some discolouration to exterior building surfaces is to be expected. Adjacent brick or masonry surfaces should be protected with a rust resistant sheet metal plate.
- Perform regularly scheduled inspections to ensure that the vent terminal is unobstructed.

### 2.5.2 Sidewall Air Inlet

Figure 7: Sidewall Vent and Air Inlet Configuration

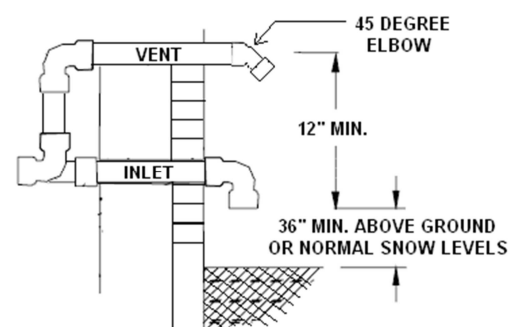

- \* Please check local codes for minimum distance above ground or snow levels

### Location of a Sidewall Air Inlet Cap

- The total length of piping for air inlet must not exceed the limits stated in Table 6.
- The point of termination for the sidewall air inlet cap must be located a minimum of 12 inches (0.30m) away from the flue gas termination, but never above.

- 3) The air piping must terminate in a down-turned elbow to avoid recirculation of flue products into the inlet air stream.
- 4) DO NOT terminate closer than 4 feet (1.25m) horizontally and vertically from any electric meter, gas meter, regulator, relief valve, or other equipment. In all cases local codes take precedence
- 5) DO NOT terminate the air inlet in a window well, stairwell, alcove, courtyard or other recessed area as wind eddies could affect performance or cause recirculation.
- 6) The air inlet cannot terminate below grade.
- 7) Locate terminations so they are not likely to be damaged by foreign objects, or exposed to build-up of debris.
- 8) Perform regularly scheduled inspections to ensure that the air inlet terminal is unobstructed.

### Termination and Fittings

- 1) The air inlet opening must be at least 12 inches (0.30m) away from (never above) the vent termination and at least 3 feet (1m) above grade or above normal maximum snow levels.

### 2.5.3 Sidewall Concentric Vent/ Air

A listed concentric vent kit can be used with the TH appliance. Both combustion air and vent pipes must terminate outside the structure.

- 1) The total length of piping for venting or air must not exceed the limits stated in Table 8.
- 2) The bottom of the termination shall be located at least 3 feet (1m) above grade or above normal snow levels. In all cases the appliance shall be installed in accordance with local codes
- 3) The termination MUST NOT terminate below a forced air inlet at any distance
- 4) The termination cannot terminate below grade. Position the termination where vapours will not damage walls or plants or may be otherwise objectionable.
- 5) The termination shall not be installed closer than 3 feet (1m) from an inside corner of an L-shaped structure, window well, stairwell, alcove, courtyard or other recessed area as wind eddies could affect boiler performance or cause recirculation.
- 6) DO NOT terminate closer than 4 feet (1.25m) horizontally and vertically from any electric meter, gas meter, regulator, relief valve, or other equipment. In all cases local codes take precedence
- 7) Position termination so they are not likely to be damaged by foreign objects, or exposed to a build-up of debris.
- 8) Flue gas condensate can freeze on exterior walls or on the vent cap. Frozen condensate on the vent cap can result in a blocked flue condition. Keep the vent cap/terminal clear of snow, ice, leaves, debris etc. Some discolouration to exterior building surfaces is to be expected. Adjacent brick or masonry surfaces should be protected with a rust resistant sheet metal plate.
- 9) Perform regularly scheduled inspections to ensure that the termination is unobstructed.

- 10) Operate the appliance for one heat cycle to ensure combustion air and vent pipes are properly connected to the concentric vent termination connections.

**CAUTION**

Do not operate appliance with the rain cap removed as this may result in the recirculation of flue products. Water may also flow into the combustion air pipe and into the burner enclosure.

**Figure 8: Concentric Sidewall Termination**

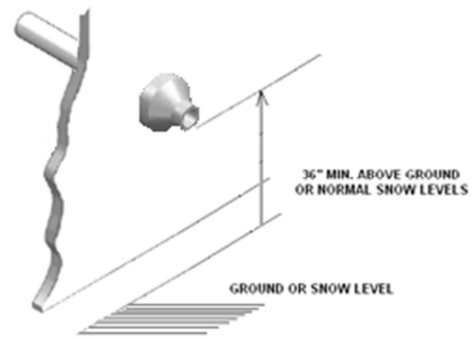

**Figure 9: Concentric Vent Sidewall**

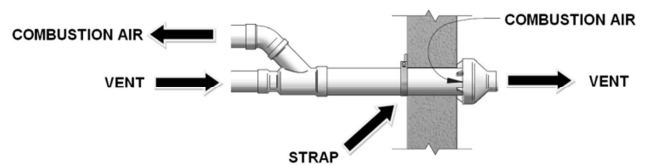

## 2.6 Vertical Direct Venting

### Location of Vent Termination

- 1) The total length of piping for venting must not exceed the limits stated in Table 6.
- 2) The vent piping must terminate in a 90° elbow if plastic piping is used or in an approved vent cap if using metal venting. The vent outlet must be at least 1 foot away and 1 foot above from the air inlet opening which must terminate in a double elbow facing downwards.
- 3) The vertical termination must be a minimum of 3 feet (1m) above the point of exit.
- 4) A vertical termination less than 10 feet (3.05m) from a parapet wall must be a minimum of 2 feet (0.61m) higher than the parapet wall.
- 5) DO NOT terminate closer than 4 feet (1.25m) horizontally and vertically from any electric meter, gas meter, regulator, relief valve, or other equipment. In all cases local codes take precedence.
- 6) Position the air inlet and vent terminations so they are not likely to be damaged by foreign objects, or exposed to build-up of debris.
- 7) Perform regularly scheduled inspections to ensure that the vent terminal is unobstructed.

### Location of a Vertical Air Inlet Opening

- 1) The total length of piping for inlet air must not exceed the limits given in Table 6.
- 2) The air inlet consists of two 90° elbows installed at the point of termination for the vertical air inlet pipe. A 90° elbow and a 90° street elbow may be used to make this assembly. If a straight piece of pipe is used between the two elbows, it should not exceed 6" (0.15m) in length. The air inlet opening must be at least 1 foot below the vent opening. The air piping must be no further than 2 feet (0.6m) from the center of the vent pipe. This arrangement avoids exhaust gases from re-circulating into the inlet air stream. Refer to Figure 8.
- 3) Air inlet must terminate at least 3 feet (1.0m) above the roof or normal snow levels and at least 1 foot (0.3m) below the vent termination.
- 4) Locate terminations so they are not likely to be damaged by foreign objects or exposed to build-up of debris.
- 5) Perform regularly scheduled inspections to ensure that the air inlet terminal is unobstructed.

**Figure 10: Vertical Direct Venting Configuration**

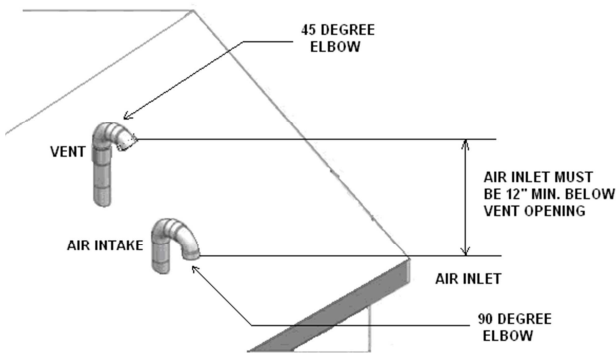

### Vertical Concentric Vent/ Air

A concentric vent kit can be used with the TH appliance. Both combustion air and vent pipes must terminate outside the structure.

- 1) The total length of piping for venting or air must not exceed the limits stated in Table 8.
- 2) The bottom of the termination shall be located at least 3 feet (1m) above grade or above normal snow levels. In all cases the appliance shall be installed in accordance with local codes
- 3) The termination **MUST NOT** terminate below a forced air inlet at any distance
- 4) The termination cannot terminate below grade. Position the termination where vapours will not damage walls or plants or may be otherwise objectionable.
- 5) The termination shall not be installed closer than 3 feet (1m) from an inside corner of an L-shaped structure, window well, stairwell, alcove, courtyard or other recessed area as wind eddies could affect boiler performance or cause recirculation.
- 6) **DO NOT** terminate closer than 4 feet (1.25m) horizontally and vertically from any electric meter, gas meter, regulator, relief valve, or other equipment. In all cases local codes take precedence

- 7) Position termination so they are not likely to be damaged by foreign objects, or exposed to a build-up of debris.
- 8) Flue gas condensate can freeze on exterior walls or on the vent cap. Frozen condensate on the vent cap can result in a blocked flue condition. Keep the vent cap/terminal clear of snow, ice, leaves, debris etc. Some discoloration to exterior building surfaces is to be expected. Adjacent brick or masonry surfaces should be protected with a rust resistant sheet metal plate.
- 9) Perform regularly scheduled inspections to ensure that the termination is unobstructed.
- 10) Operate the appliance for one heat cycle to ensure combustion air and vent pipes are properly connected to the concentric vent termination connections.

<b>CAUTION</b>
Do not operate appliance with the rain cap removed as this may result in the recirculation of flue products. Water may also flow into the combustion air pipe and into the burner enclosure.

**Figure 11: Concentric Vent Vertical Venting**

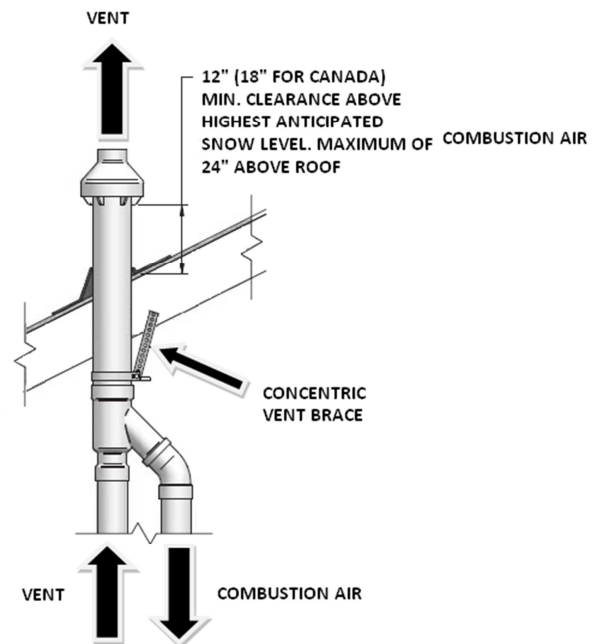

### Length of Air Inlet Pipe

The maximum total length of the sidewall or vertical roof top combustion air inlet pipe as installed from the appliance to the air inlet cap must not exceed 100 equivalent feet (30.5m) in length. Subtract 3 to 5 feet (1 to 1.5m) of equivalent length depending on centerline radius for each 90° elbow installed in the air inlet pipe system. Pressure drop in each 45° elbow will be half as much, 2 to 3 feet (0.6 to 1.0m).

## PART 3 GAS CONNECTION

Verify that the appliance is supplied with the type of gas specified on the rating plate. Consult factory for installations at high altitude.

### 3.1 GAS CONNECTION

- Safe operation of unit requires properly sized gas supply piping. See gas line sizing data.
- Gas pipe size may be larger than appliance connection.
- Installation of a union at the appliance gas line connection is required for ease of service and removal of the gas train.
- Install a manual main gas shutoff valve, outside of the appliance gas connection as require by local codes.
- A trap (drip leg) MUST be provided in the inlet gas connection to the appliance.
- Optional gas controls may require routing of bleeds and vents to the atmosphere, outside the building when required by local codes.

**Table 7: Recommended Gas Pipe Size**

Single Appliance Installation  
(For distance from natural gas meter or propane second stage regulator)

Input Btu/Hr, x1000	0-100 FT		101-200 FT		201-300 FT	
	NAT.	L.P.	NAT.	L.P.	NAT.	L.P.
80	¾"	½"	¾"	½"	1"	¾"
100	¾"	½"	1"	¾"	1"	¾"
150	1"	¾"	1 ¼"	1"	1 ¼"	1"
199	1"	¾"	1 ¼"	1"	1 ¼"	1"
250	1 ¼"	1"	1 ¼"	1"	1 ½"	1 ¼"
299	1 ¼"	1"	1 ½"	1 ¼"	1 ½"	1 ¼"
399	1 ¼"	1"	1 ½"	1 ¼"	2"	1 ½"
500	1 ½"	1 ¼"	2"	1 ½"	2"	1 ½"
600	1 ½"	1 ¼"	2"	1 ½"	2"	1 ½"
700	2"	1 ½"	3"	2 ½"	3"	2 ½"
800	2"	1 ½"	3"	2 ½"	3"	2 ½"

### 3.2 GAS PIPING

All gas connections must be made with pipe joint compound resistant to the action of liquefied petroleum and natural gas. All piping must comply with local codes and ordinances.

### 3.3 INSTALL PIPING

- The gas line should be sufficient to handle the total installed capacity. Verify pipe size with your gas supplier.
- Use approved piping as per code free from burrs.
- Install a manual main gas shutoff valve at the appliance gas inlet, outside of the appliance and before the gas valve.
- Run pipe to the Appliance gas inlet.
- Install a sediment trap in the supply line to the Appliance gas inlet.
- Apply a moderate amount of good quality pipe compound.
- For LP gas, consult your LP gas supplier for expert installation.

The appliance and its individual gas shut-off valve must be disconnected from the supply piping when pressure testing the gas supply piping at pressures above ½ PSI

**Table 8: Gas Pressures at Inlet to Appliance**

	PROPANE	NATURAL GAS
Minimum (inches W.C.)	11	3
Maximum (inches W.C.)	11	14

The gas supply line must be of adequate size to prevent undue pressure drop and must never be smaller than the size of the connection on the appliance. Sizing based on Table 8 is recommended, depending on model.

Before operating the appliance, the complete gas train and all connections must be tested using soap solution.

Verify that the appliance is supplied with the type of gas specified on the rating plate. Heating values of local natural gas are to be between 950 and 1010 Btu/ft<sup>3</sup>. Consult factory if heating values are outside this range or if a gas with a mixture of constituents is being used.

### 3.4 CHECKING GAS SUPPLY PRESSURE

- Turn the main power switch to "OFF" position.
- Shut off gas supply at the manual gas cock in the gas piping to the appliance. If fuel supply is LP gas, shut off gas supply at the tank.
- Remove the 1/8" hex plug from the gas pressure test port located on the inlet gas supply connection at the rear of the appliance. Install a fitting in the inlet pressure tapping suitable to connect to a manometer or magnahelic gauge. Range of scale should be 0 to 14 inch W.C. or greater to check inlet pressure
- Turn on gas supply at the field installed manual gas cock; turn on LP gas at tank if required.
- Turn the power switch to "ON" position.
- Adjust the thermostat set point to call for heat.
- Observe the gas supply pressure as the burner fires at 100% of rated input. Supply pressure is to remain stable.
- Ensure inlet pressure is within specified range. Minimum and maximum gas supply pressures are specified in Table 8.
- If gas pressure is out of range, contact the gas utility, gas supplier, qualified installer or service agency to determine necessary steps to provide proper gas pressure to the control.
- If gas supply pressure is within normal range, proceed to remove gas manometer and replace pressure tap fittings in the gas piping to the appliance. Turn the power switch to "OFF" position.
- Turn on gas supply at the manual valve; turn on LP gas at tank if required.
- Turn the power switch to "ON" position.
- Adjust the thermostat temperature set point to the desired water temperature so the appliance will call for heat.
- Check appliance performance by cycling the system while you observe burner response. The burner should ignite promptly. Flame profile should be stable, see section 10.2, Visually Check Main Burner Flames. Turn system off and allow burner to cool, then cycle burner again to ensure proper ignition and flame characteristics.

### IMPORTANT

Upon completion of initial installation or following any repair work on the gas system, leak test all gas connections with a soap solution while the main burner is firing. Immediately repair any leak found in the gas train or related components. DO NOT operate an appliance with a leak in the gas train, valves or related gas piping.

### 3.5 HIGH and LOW GAS PRESSURE SWITCHES (Optional)

High and low gas pressure switches are available as an option and are wired in series with the blocked flue switch. The high gas pressure switch is used to monitor the differential gas pressure between the outlet of the control valve and the fan inlet. If differential gas pressure exceeds the maximum setting of the pressure switch, the appliance will shut down and a low air condition will be indicated on the display panel. The low gas pressure switch is to monitor the minimum incoming gas supply pressure supplied to the gas train. If gas pressure falls below the minimum setting of the pressure switch, the appliance will shut down and a low air condition will be displayed on the display panel.

### 3.6 AIR/GAS RATIO VALVE

The main gas valve supplying gas to the burner on this appliance utilizes a servo pressure regulator providing a slow opening, fast closing safety shut off and air/gas ratio control for the gas combustion process. The valve is a 1:1 negative pressure gas valve. The valve performs the functions of a pressure regulator, safety shutoff, and air/gas ratio control. Full closing of the valve seat occurs in less than 0.8 seconds when the valve is de-energized. Operation of the gas valve in combination with the combustion air fan allows the burner input rate to vary from 20% to 100% based on temperature demand. The inlet gas supply pressure must be maintained within the specified minimum and maximum pressures.

The air/gas ratio is preset at the factory and adjustment is not usually required if gas supply pressure is maintained within the specified range.

There are no serviceable parts on the air/gas ratio valve control.

Figure 12: TH 82 – 252 1:1 Air/Gas Ratio Control Valve

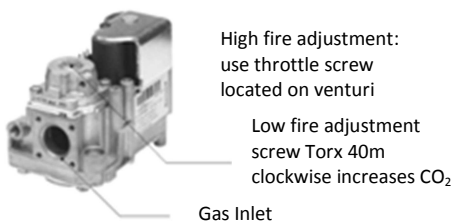

Figure 13: TH 292 – 392 1:1 Air/Gas Ratio Control Valve

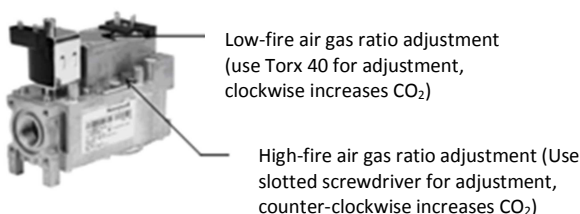
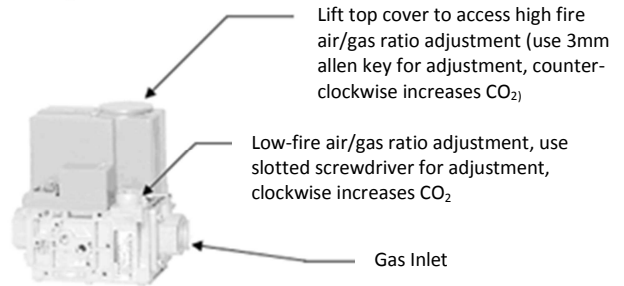

Figure 14: TH 502 1:1 Air/Gas Ratio Control Valve



### 3.7 BURNER

Figure 15: TH Burner



This appliance uses a single cylindrical burner installed horizontally into the cavity located in the center of the heat exchanger. There is a unique burner for each one of the TH models.

**Burners may NOT** be interchanged between different Btu/hr input models. The burner consists of a round mounting flange welded to a ported stainless steel mixing tube. This stainless steel tube is covered with a close fitting, knitted stainless steel metal fiber alloy material that forms the burner outer surface. The burner is setup to operate in blue mode and infrared operating condition should be avoided. Infrared operation will occur only if air to gas adjustments is incorrect. If infrared operation is noted the cause must be corrected.

The burner should be removed for inspection and cleaning on an annual basis. An appliance installed in a dust or dirt contaminated environment will require inspection and cleaning on a more frequent schedule. The fan assisted combustion process may force airborne dust and dirt contaminants, contained in the combustion air, into the burner. With sustained operation, non-combustible contaminants may reduce burner surface area, reduce burner input or cause non-warrantable damage to the burner.

Airborne contaminants such as dust, dirt, concrete dust or dry wall dust can be drawn into the burner with the combustion air and block the burner surface area. **DO NOT** operate this appliance during construction.

The spark igniter and flame sensor are removable from the combustion chamber mounting door without removing the burner assembly.

**Never use an open flame (match, lighter, etc.) to check gas connections.**



## PART 4 WATER CONNECTION

- Check all applicable local heating, plumbing and building safety codes before proceeding.
- If the appliance is installed above radiation level it must be provided with a low water cut-off device at the time of appliance installation (available from Camus). Some local codes require the installation of a low water cut-off on all systems.
- A temperature and pressure relief valve is supplied with each TH. The relief valve must be mounted in a vertical position and piped to the floor in a manner acceptable to the enforcing authority.
- Be sure to provide unions and gate valves at inlet and outlet to the appliance so that it can be easily isolated for service.
- This appliance is a low mass stainless steel tube design which provides for instant heat transfer. All appliances are supplied with an internal suitable specific pump mounted in place. When replacing the pump, replace with one of equal or better-performance.
- An air vent is supplied on the heat exchanger header to eliminate trapped air. Install venting devices at high points in the system as well to eliminate trapped air in the piping.
- Use suitable pipe hangers or floor stands to support the weight of all water and gas piping.
- The TH must be installed so that the gas ignition system components are protected from water (dripping, spraying, rain, etc.) during appliance operation and service (circulator replacement, control replacement, etc.)

### 4.1 INLET AND OUTLET CONNECTIONS

- All water connections must meet American National Standard Pipe Threads (NPT).
- For ease of service, install unions on inlet and outlet of the appliance. The connection to the appliance marked "Inlet" on the header should be used for return from the system. The connection on the header marked "Outlet" is to be connected to the supply side of the system.

### 4.2 MINIMUM PIPE SIZE REQUIREMENTS

Minimum water pipe connections are as follows for TH single unit installations. The equivalent number of straight feet of pipe for each valve and fitting in the connecting piping must be considered to properly arrive at the total equivalent feet of straight pipe in the field installed piping to the appliance. Consult factory if longer piping distances are required for a specific application. It is recommended to use copper piping for all system piping to reduce the possibility of the formation of deposits, which may result in heat exchanger starvation.

System pipe size must be in accordance with Table 9 (depending on model). Connection sizes at the heater are given in Table 4.

Table 9: Minimal System Pipe Size

Input, Btu/Hr	Water Size, NPT [in.]
80,000	1
100,000	1
150,000	1
199,000	1
250,000	1 1/4
299,000	1 1/4
399,000	1 1/2
500,000	1 1/2

### 4.3 HEAT EXCHANGER

This appliance uses precision formed stainless steel tubing to maximize the heat transfer process and achieve 97% steady-state efficiency. This heat exchanger is designed to withstand 160 PSIG working pressure.

A factory installed circulating pump ensures proper water flow during burner operation and creates enough velocity inside the stainless steel tubes and headers that prevents scaling.

### 4.4 LOW WATER TEMPERATURE SYSTEMS

In combination applications where the heating system requires supply water temperatures below 110°F, connections may be made directly to the TH (Refer to Figure 35). At incoming temperatures of 80°F or lower the TH achieves maximum efficiency. Inlet temperatures must not drop below 40°F to prevent freezing.

### 4.5 PIPING ARRANGEMENTS

#### 4.5.1 Field Supplied Components

##### 1) Heater system piping

Boiler system piping MUST be sized according to Table 9. Reducing the pipe size can restrict the flow rate through the tank and cause an excessive pressure drop.

##### 2) Isolation Valves

Use only full port ball valves. Failure to supply full port ball valves may result in reduced flow rate through the tank.

##### 3) Anti-Scald Mixing Valve

An anti-scaled mixing valve is recommended when DHW storage is above 120°F.

##### 4) Unions

Recommended for ease of serviceability.

##### 5) System Temperature Sensor

A system temperature sensor is to be installed in the main header at a point to detect controlled temperature and where it will not lead to short-cycling of the boiler.

**Table 10: Flow and Pressure Drop at a Given Temperature Rise (DHW)**

Input, Btu/Hr	20 F (11.1 °C) Temp Rise	
	USGPM (min. flow)	ΔP Ft.
80,000	7.5	11.5
100,000	9.4	26.9
150,000	14.0	27.8
199,000	19.2	25.9
250,000	23.5	28.3
299,000	28.8	25.8
399,000	38.4	23.9
500,000	48.6	29.4

**4.6 FLOW PROVING DEVICE**

**Figure 16: Flow Proving Device**



The flow proving device is designed to detect when flow is present. This is done by detecting the amount of current (amperes) that exists in the live wire to the pump. When the current becomes too low a flow switch error is displayed indicating a lack of water flow inside the boiler.

Wall Mount	
LED Illuminated	Symptom
TRIP ON	Normal operation
TRIP OFF	Current under trip point

**4.7 T&P RELIEF VALVE**

This appliance is supplied with a T&P relief valve sized in accordance with ASME Boiler and Pressure Vessel Code, Section IV. To prevent water damage, the discharge from the relief valve shall be piped to a suitable floor drain for disposal when relief occurs. No reducing couplings or other restrictions shall be installed in the discharge line. The discharge line shall allow complete drainage of the valve and line. Relief valves should be manually operated at least once a year.

**CAUTION**  
Avoid contact with hot discharge water

**4.8 STAINLESS STEEL STORAGE TANK**

The TH is equipped with a stainless steel storage tank. A 20 gallon tank is supplied with TH Models 082 – 152, and a 40 gallon tank is supplied with TH Models 202 – 502. The storage tanks are CSA certified and are rated to operate at a maximum working pressure of 160 psig.

**PART 5 ELECTRICAL & CONTROLS**

**⚠ DANGER**  
IT IS EXTREMELY IMPORTANT THAT THIS UNIT BE PROPERLY GROUNDED!

**5.1 ELECTRICAL CONNECTIONS**

Minimum 120VAC 60Hz single phase (15A circuit) is required for the TH models TH-082 through TH-502. The appliance, when installed, must be electrically grounded in accordance with the requirements of the authority having jurisdiction or in the absence of such requirements, with the latest edition of the National Electrical Code ANSI/NFPA No. 70. When the unit is installed in Canada, it must conform to the Canadian Electrical Code, C22.1, Part 1 and/or local Electrical Codes.

- All wiring between the appliance and field installed devices shall be made with wire having minimum 220°F (105°C) rating.
- Line voltage wire exterior to the appliance must be enclosed in approved conduit or approved metal clad cable.
- The pump must run continuously when appliance is being fired.
- To avoid serious damage, DO NOT ENERGIZE the appliance until the system is full of water. Ensure that all air is removed from the pump housing and piping before beginning initial operation. Serious damage may result if the appliance is operated without proper flow.
- Provide the appliance with proper overload protection.

**5.2 HIGH LIMIT**

A manual reset fail-safe high limit aqua-stat control is internal to the TH controller and the control bulb is installed in a dry well in the heat exchanger outlet. The setting of this control limits maximum discharge water temperature to 210°F. The temperature of the outlet water in the heat exchanger must drop a minimum of 5°F (2.7°C) below the setting of the high limit control before the reset function can be activated.

**5.3 TH CONTROLLER**

This appliance uses a direct spark ignition control system. The operation of the TH Controller for the direct spark igniter proves the presence of main flame using a flame sensor proof current (0.8µA). A status point alarm of Flame Fail will be displayed on the main panel if the boiler fails to light after three (3) ignition attempts.

**Table 11: Connector Description**

Connector	Connector Description
J1	Flame Sensor, Ground Rod
J2	Fan Modulation
J3	Display
J4	24VAC Power
J5	Gas Valve, Safety Interlock String
J6	Safety Annunciation, Remote Operator
J8	24VAC Power, Outlet Sensor
J9	Inlet/DHW, Stack Sensor

**5.3.1 Service Parts**

The TH Controller is not repairable. Any modification or repairs will invalidate the warranty and may create hazardous conditions that result in property damage, personal injury, fire, explosion and/or toxic gases. A faulty direct spark igniter **MUST** be replaced with a new factory part. **DO NOT** use general purpose field replacement parts. Each appliance has one TH Controller, one direct spark igniter and one flame sensor. A list of recommended spare parts is available.

**5.3.2 Ignition Module Lockout Functions**

The TH Controller may lockout in either a lockout condition requiring pushing the reset button to recycle the control for a CSD1 requirement or an alert condition. A typical lockout fault for the TH Controller occurs when the fan modulation signal is disconnected. Pushing the reset button on the control panel is the only way to reset the TH Controller that is in a lockout condition. Turning the main power "OFF" and then "ON" or cycling the thermostat will not reset a lockout condition. Wait five seconds after turning on the main power before pushing the RESET button when the TH Controller is in a lockout condition. Wait for the status LCD display to refresh indicating that the TH Controller is ready before releasing the reset button.

The TH Controller will go into an alert condition, for example, if the supply sensor is disconnected, flow switch, or air switch are not made. If the fault is not corrected, the boiler will stay in an alert condition. Once the fault is corrected, the boiler will automatically return to normal operating state

**5.4 ERROR TABLE**

The following tables provide a description of all the possible errors with the TH boiler. Errors can be divided into two groups. Alert errors (will disappear when error is gone) and lockout errors (can only be reset by the RESET button).

When the control is in error the pump will be running. This is done to prevent the freezing of the central heating circuit when the boiler is in error during the winter period. For some non-volatile lockouts the pump will not be running, see table below for more details.

**5.4.1 Lockout Codes**

**Table 12: Lockout Codes**

#	Description
0	None
1-31	Internal hardware error
47	Flame rod to ground leakage
48	Static Flame
49	24VAC low/high
64	Fan speed not proved, ignition failure
67	Blocked flue condition
79	Heater Outlet high limit tripped
91	Inlet sensor fault
92	Outlet sensor fault
93	DHW sensor fault
95	Stack sensor fault
105	Flame detected out of sequence
106, 107, 108	Flame lost during run
109, 110	Ignition Failure Occured
132	Fan Speed Fault

**5.4.2 Alert Codes**

**Table 13: Alert Codes**

#	Description
0	None
29	Burner Switch was turned OFF
30	Burner Switch was turned ON
61	Anti-short Cycle
62	Fan speed not proved
63	LCI off
64	Burner control firing rate < absolute min rate
66	Burner control rate (non-firing) was invalid, % vs. RPM
67, 68	Flow Switch, Blocked Flue Switch
75	Absolute max fan speed was out of range
76	Absolute min fan speed was out of range
79	Outlet high limit tripped
82	Stack limit tripped
91	Inlet sensor fault
92	Outlet sensor fault
93	DHW sensor fault
95	Stack sensor fault
291	Flame was not on at end of Ignition period
294	Abnormal Recycle
303	Safety string failed to close
309	Not safe to start due to high limit
310	Flow Switch or Blocked Flue Switch tripped during Burn state
318	Stuck reset switch
361	Internal hardware error
-	
500	



## PART 6 CONTROL PANEL

### 6.1 TH CONTROLLER

The appliance is provided with an operator interface panel at the front. The TH Controller can be accessed by removing the black-coloured top cover steel jacket which is held on by two (2) screws. The front upper jacket can simply be removed by pulling the panel towards you.

The Boiler Temperature Controller (BTC) for this appliance is a proprietary Camus TH Controller. It initiates the local call for heat and sets the target temperature, inlet water temperature. This controller provides the following:

- Readings of inlet and outlet water temperatures stack temperatures, domestic hot water temperature, flame current, status of heater operation, etc.
- Operation as an auto reset high limit.
- Adjustable target temperature
- Molex, Lumberg and OST connectors for ease of service.
- Error message display.

### 6.2 SETTING THE TH CONTROLLER

Press the 'Next' button to view the desired setting. When the desired setting is satisfied press the **[UP]/[DOWN]** key and this will save the last setting. In normal operating mode the DHW/Inlet temperature and the status of the heater is shown.

### 6.3 DOMESTIC HOT WATER OPERATION

#### DHW Storage Tank with Temperature Sensor

The DHW temperature is measured with the heat exchanger inlet sensor and set with parameter DHW setpoint. When the DHW sensor drops below 'DHW setpoint – DHW on hysteresis' the control detects a demand for the storage tank and activates the pump. If the DHW temperature continues to drop the ignition sequence will begin. When the burner is lit the load is PID-modulated so the supply is regulated towards DHW setpoint. The burner will fire at steady-state or it shall shut off if the DHW temperature is greater than 'DHW setpoint + DHW off hysteresis'. The on-board pump will continue to circulate until the pump overrun timer is satisfied.

Frost Protection: To prevent freezing of the heat exchanger, the on-board pump is turned on if the DHW temperature is below 45°F. The on-board pump remains on until the DHW temperature exceeds 50°F. When this occurs the DHW pump continues to circulate until the post-pump timer is satisfied. If the DHW temperature continues to fall below 38°F the controller requests a minimum modulation fire rate. This operation continues until the DHW temperature exceeds 50°F.

## PART 7 COMPONENTS

### 7.1 DIRECT SPARK IGNITER

The direct spark igniter is inserted directly through the combustion chamber front door and held in place by two torx screws. Care must be taken when removing and/or installing the igniter. Always remove the igniter prior to removing the fan assembly for inspection of the burner and heat exchanger.

**Figure 17: Direct Spark Igniter**



During a trial for ignition sequence a properly operating igniter will generate a continuous spark with a 9/64" (3.6mm) spark gap. It is recommended to clean the direct spark igniter using steel wool as required. **DO NOT** use sandpaper or grit-cloth since this will contaminate the metal surface.

### 7.2 FLAME SENSOR

The flame sensor is inserted directly through the combustion chamber front door and is screwed into the combustion chamber front door. Care must be taken, when installing the flame sensor, to align it perpendicular to the fan flange and parallel to the burner tube and not to over tighten.

**Figure 18: Flame Sensor**

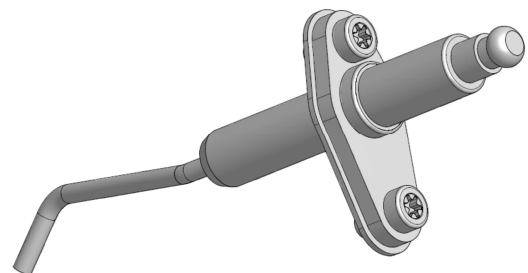

The ignition module relies on the flame sensor to provide a flame rectification signal. Oxide deposits, improper placement or damaged ceramic insulator will result in insufficient signal leading to ignition module lock out. For proper operation minimum 0.8  $\mu$ A DC must be fed back to the module. Oxide deposit on the sensor rod must be removed with steel-wool. **DO NOT** use sand-paper since this will contaminate the metal surface.

### **7.3 COMBUSTION AIR FAN**

TH uses a modulating air fan to provide combustible air/gas mix to the burner and push the products of combustion through the heat exchanger and venting system. The fan assembly consists of a sealed housing and fan wheel constructed from spark resistant cast aluminum. The fan is operated by a fully enclosed 120 VAC, Single-Phase EC/DC electric motor. The fan housing and motor assembly is fully sealed and SHOULD NOT be field serviced. The power draw of the motor is proportional to the modulated gas input rate of the appliance.

### **7.4 GAS VALVE**

**Figure 19: Venturi and Gas Valve Arrangement**

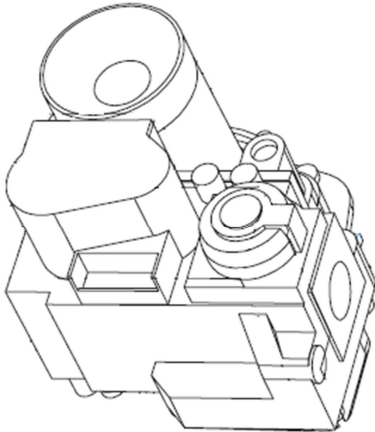

The Gas Valve supplied with the TH is a combined valve/venturi assembly. A servo pressure regulator is incorporated into the gas valve to provide stable gas supply. Pressure taps are provided to check inlet and outlet gas pressures. An internal fine mesh screen is incorporated in the inlet of the gas valve to prevent debris from entering the combustion chamber. Gas valves are factory set at low and high fire and modulates to maintain combustion characteristics across the full operating range.

### **7.5 OUTER JACKET**

The outer jacket assembly is constructed from mirror finish stainless steel. This ensures a long life for the jacket assembly, with full integrity

## PART 8 TH CONTROL PANEL

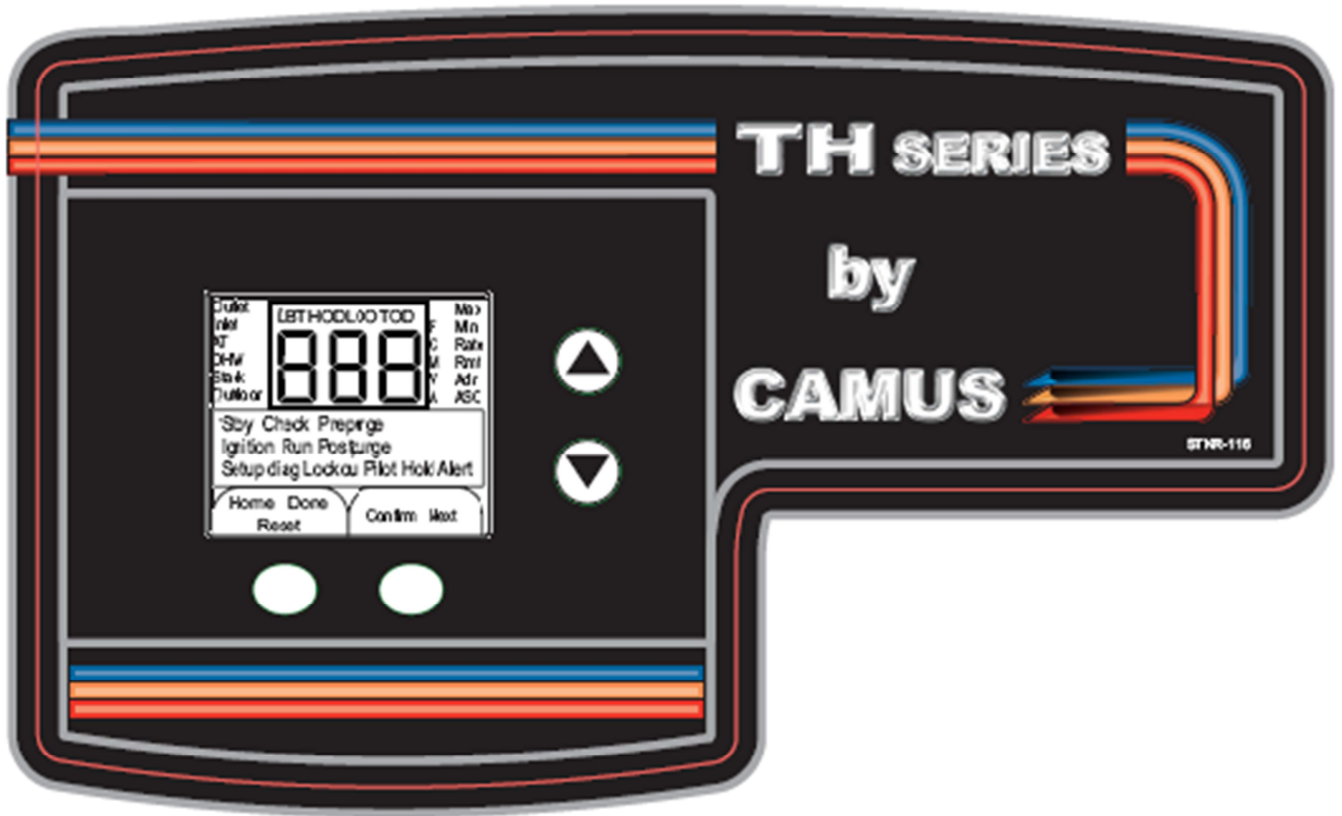

### HOME/DONE/RESET

- Reset Lockout errors
- Return to previous menu mode

### CONFIRM/NEXT

- Scroll forward through the parameter structure
- Store parameter value



- Pressing the button changes the setpoints in one degree increments
- Pressing and holding the button changes the setpoints in five degree increments



- Pressing the button changes the setpoints in one degree decrements
- Pressing and holding the button changes the setpoints in five degree decrements

## 8.1 INTRODUCTION TO THE TH CONTROL PANEL

The menu structure for the TH Control Panel was designed to be intuitive and easy to use for a first time user. To maintain the TH boiler at its correct settings three levels of security is provided. User, Setup and Diagnostic with an increasing amount of parameters that can be adjusted with each higher level of access. This is done to provide an easy means of communication for the end user and a more in-depth approach for factory and installers when installing and troubleshooting.

Figure 20: TH Control Panel Layout

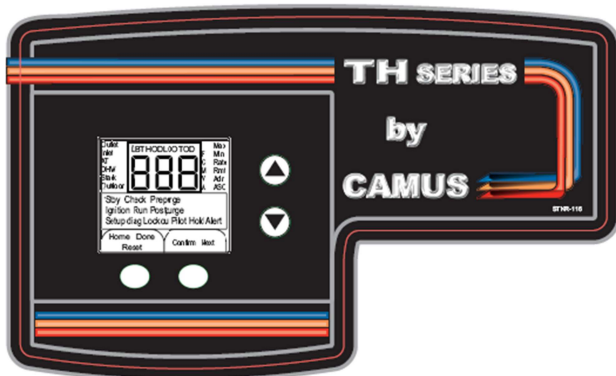

Table 14: TH Control Panel Key Functions

KEY	KEY DESCRIPTION
HOME/DONE/RESET	<ul style="list-style-type: none"> <li>- Reset Lockout errors</li> <li>- Return to previous menu mode</li> </ul>
CONFIRM/NEXT	<ul style="list-style-type: none"> <li>- Scroll forward through the parameter structure</li> <li>- Store parameter value</li> </ul>
UP	<ul style="list-style-type: none"> <li>- Pressing the button changes the setpoints in one degree increments</li> <li>- Pressing and holding the button changes the setpoints in five degree increments</li> </ul>
DOWN	<ul style="list-style-type: none"> <li>- Pressing the button changes the setpoints in one degree decrements</li> <li>- Pressing and holding the button changes the setpoints in five degree decrements</li> </ul>

### Startup Display

Upon startup of the TH all text on the LCD will be shown for 2 seconds, followed by the software version number for an additional 2 seconds. The Version # relates to the version of software uploaded onto the boiler control.

The display panel then defaults to the outlet temperature display and communicates with the TH Controller. At this time dashes will be displayed in the numerical part of the LCD, along with 'Outlet' and '°F'.

Figure 21: TH Home Screen



After a certain period of user inactivity the display times out and switches to the home screen. Setpoint changes made prior to the timeout will be saved. Pressing the Done button after changing a setpoint also saves the new setpoint.

Table 15: Timeouts in User Mode

Screen Displayed	Length of Inactivity that Causes Timeout
DHW Water Setpoint Temp	10 seconds
Outlet Water Temp	1 minute
Inlet Water Temp	
Delta T	
DHW Water Temp	
Stack Temp	
Outdoor Temp	
Firing Rate	

Table 16: Timeouts in Setup Mode





Screen Displayed	Length of Inactivity that Causes Timeout
Temperature Scale	1 minute
Outdoor Reset	
Remote Firing Control	5 minutes
Anti-short Cycle	

Table 17: Timeouts in Diagnostic Mode

Screen Displayed	Length of Inactivity that Causes Timeout
Flame Current	5 minutes
Alert Code	
Lockout Code	
Maximum Outlet Temperature	
Maximum Stack Temperature	
Maximum DHW Temperature	
Minimum Firing Rate	
Maximum Firing Rate	
Manual Firing Rate	

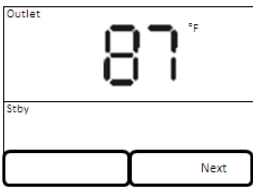
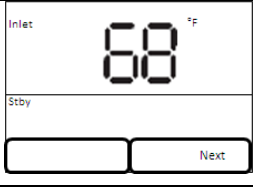
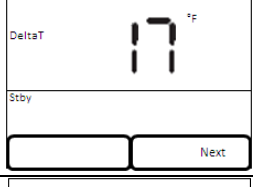
## 8.2 USER MODE

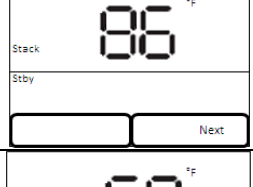
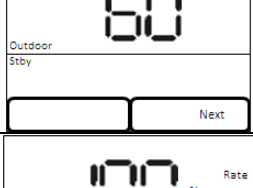
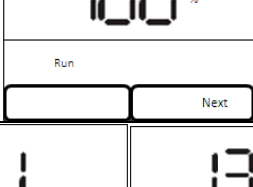
- 1) To access the User menu press the 'Next' button to scroll through the parameters.





Display	Display Readout	Description
	Outlet Water Temperature	Display current heater Supply/ Outlet Water Temperature. When <b>[UP]/[DOWN]</b> is pressed this allows the DHW setpoint temperature to be changed. Range: 32 – 230°F (0 – 110°C) <b>Default: 145°F (63°C)</b>
	Inlet water Temperature	Display current heater Return/Inlet Water Temperature
	Delta Temperature	Display delta T temperature [(Outlet Temperature) – (Inlet Temperature)]
	DHW Temperature	Display DHW temperature. When <b>[UP]/[DOWN]</b> is pressed this allows the DHW setpoint temperature to be changed. Range: 32 – 230°F (0 – 110°C) Default: 145°F (63°C)
	Stack Temperature	Display Stack Temperature
	Outdoor Temperature	Display Outdoor Temperature (if equipped)
	Firing Rate	Display current boiler firing rate value
	Lead Lag Header Temperature (not used)	Display and modify current Lead Lag setpoint temperature

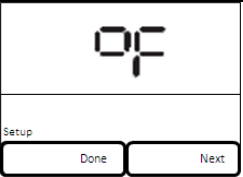
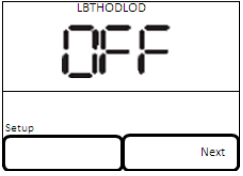
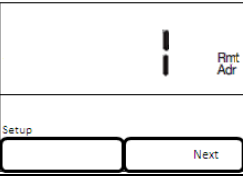
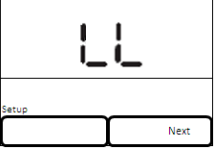

### 8.3 SETUP MODE

From User Mode:

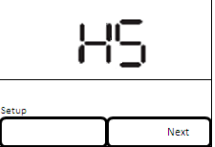
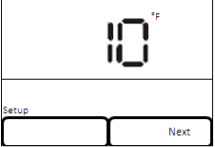
- 1) Press and hold the **[UP]/[DOWN]** buttons for 3 seconds.
- 2) The 'Setup' icon will be displayed in the Operating Mode portion of the display. The user can change screens by pressing the 'Next' button

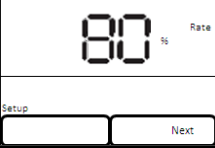
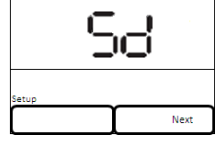
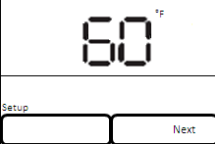
**NOTE:** Accessing the Setup Mode will put the TH Control Board into Standby. If the heater is firing, the TH Control Board will post-purge and go to Standby. The system will remain in Standby until the Done button is pressed or the inactive timeout time has elapsed.

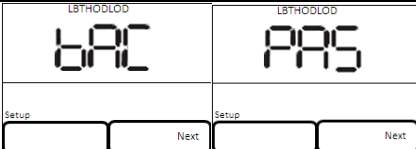

Display		Display Readout	Description
		Temperature Scale	Set display to either degrees Fahrenheit or degrees Celcius Range: °F, °C
		LBTHODLOD (not used)	LBT Low Boiler Reset Temperature Range: Off, On: 32 to 230°F (0 – 110°C) Default: Off
			HOD High Outdoor Reset Temperature Range: Off, On: -40 to 230°F (-40 – 110°C) Default: Off
			LOD Low Outdoor Reset Temperature Range: Off, On: -40 to 230°F (-40 – 110°C) Default: Off
		Remote Firing Address	Setting the Modbus address on the Honeywell SOLA. Default: 1
		Lead Lag (not used)	Current status of Lead Lag is shown. "Ldr" (master), "SLA" (slave) or "OFF" along with the setup icon.
		Lead Lag Hysteresis (not used)	On/Off hysteresis Default: 10°F
		Base load (not used)	Indicates current base load in percentage Default: 80%
		Warm Weather Shutdown (not used)	The "Sd" icon will blink when waiting for the current WWSD value from the R7910.

	<p>Password (not used)</p>	<p>A 3-digit code "225" is required to restore the controller to its default settings. A Plug-in Module (PIM) is required to perform a backup.</p>
	<p>Anti-short cycle</p>	<p>Preset time must be satisfied before heater is allowed to start the ignition sequence. Range: 0 to 10 minutes Default: 0.3</p>

#### 8.4 DIAGNOSTIC MODE

From USER mode:

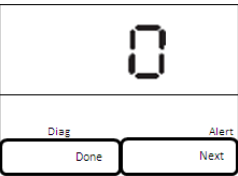
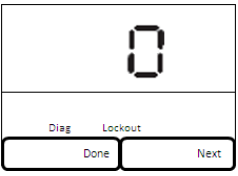
- 1) Press and hold the 'Next' button for 3 seconds.
- 2) The 'Diag' icon will be displayed in the Operating Mode portion of the display. The installer can change screens by pressing the 'Next' button

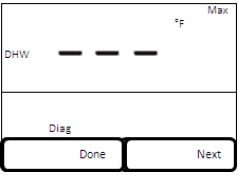
<b>Display</b>	<b>Display Readout</b>	<b>Description</b>
	<p>Flame Current</p>	<p>High Fire: 20 - 22μA Low Fire: 11 - 13μA</p>
	<p>Alert Code</p>	<p>Alerts do not require manual intervention. The last received alert code is displayed in User mode. To clear the alert code, press the Reset button.  Refer to Table 13 in Section 5.4.2 for more details. Alerts are automatic reset errors.</p>
	<p>Lockout Code</p>	<p>Lockouts cause the boiler to shutdown and require a manual reset to clear the error. The last received lockout code is displayed. Pressing the 'Reset' button clears the Lockout code and resets the TH Control.  Refer to Table 12 in Section 5.4.1 for more details. Lockouts require a manual reset on the TH display panel.</p>
	<p>Maximum Outlet Temperature</p>	<p>When outlet temperature exceeds this value. This results in an alert code being flashed.  Default: 210°F (99°C)</p>
	<p>DHW Maximum Temperature</p>	<p>This parameter does not apply to the TH as the inlet sensor to the heat exchanger acts as the DHW sensor.  Default: - - -, N/A</p>

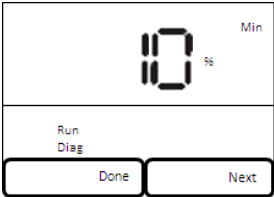
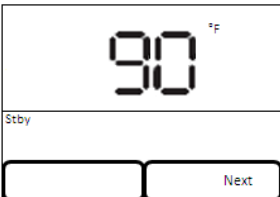
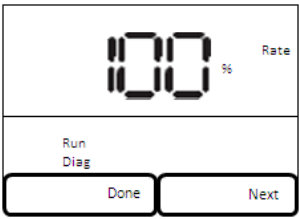
Display	Display Readout	Description
	Maximum Stack Temperature	<p>When stack temperature approaches this value the boiler will automatically reduce firing rate. If temperature continues to climb this will result in the boiler shutting down while displaying an alert code.</p> <p>PVC: 149°F (65°C)  CPVC: 194°F (90°C)  PPE: 230°F (110°C)  AL29-4C: 300°F (149°C)  316L Stainless Steel: 300°F (149°C)</p>
	Minimum Firing Rate	<p>Min icon is flashing and the Diag icon is solid. The heater will fire at the displayed modulation rate.</p> <p>The firing rate value displayed is alternated with the outlet temperature display.</p> <p>After 5 minutes of inactivity or when the 'Done' button is pressed the TH returns to normal operation.</p>
	Maximum Firing Rate	<p>Max icon is flashing and the Diag icon is solid. The heater will fire at the displayed modulation rate.</p> <p>The firing rate value displayed is alternated with the outlet temperature display.</p> <p>After 5 minutes of inactivity or when the 'Done' button is pressed the TH returns to normal operation.</p>
	Manual Firing Rate	<p>Max icon is flashing and the Diag icon is solid. TH is initially forced to 90% of firing rate (if not already operating).</p> <p>To manually adjust firing rate. Press the <b>[UP]/[DOWN]</b> button once changes the firing rate by 1%.</p> <p>Low Fire: 10%  High Fire: 90%</p> <p>After 5 minutes of inactivity or when the 'Done' button is pressed the TH returns to normal operation.</p>



## PART 9 TROUBLESHOOTING

COMPONENT	FAILURE MODE	ANALYSIS
<b>Incoming Power</b>	<ul style="list-style-type: none"> <li>• Two wires interchanged</li> </ul>	<ul style="list-style-type: none"> <li>• No effect on safety</li> <li>• Live and Neutral wires are interchanged.</li> </ul>
<b>Transformer Tripped</b>	<ul style="list-style-type: none"> <li>• The 24Volts and 120 Volts wired are interchanged</li> </ul>	<ul style="list-style-type: none"> <li>• Transformer immediately burns out, replace transformer</li> </ul>
<b>Pump Fails to Circulate</b>	<ul style="list-style-type: none"> <li>• Wiring Issue</li> </ul>	<ul style="list-style-type: none"> <li>• Check that wires are correctly wired from the TH Controller to the pump delay relay.</li> <li>• Check that 24VAC is delivered to pump coil.</li> </ul>
	<ul style="list-style-type: none"> <li>• Faulty Pump on a wet rotor pump</li> </ul>	<ul style="list-style-type: none"> <li>• Pump impeller may be stuck. Use a flat head screwdriver on face of pump to turn impeller manually</li> <li>• Replace Pump</li> </ul>
	<ul style="list-style-type: none"> <li>• Air in the piping system</li> </ul>	<ul style="list-style-type: none"> <li>• Purge all air from the piping system</li> </ul>
	<ul style="list-style-type: none"> <li>• Internal Fault on TH Controller</li> </ul>	<ul style="list-style-type: none"> <li>• Replace TH Controller</li> </ul>
<b>Relief Valve</b>	<ul style="list-style-type: none"> <li>• System pressure exceeds relief valve setting</li> </ul>	<ul style="list-style-type: none"> <li>• Replace the standard relief valve with a higher rated valve up to the maximum pressure of the heat exchanger.</li> <li>• Improperly sized expansion tank.</li> </ul>
<b>Flow Proving Device</b>	<ul style="list-style-type: none"> <li>• Flow Proving Device contacts are open</li> </ul>	<ul style="list-style-type: none"> <li>• Verify LED's on current sensing transformer during a heat demand</li> <li>• Verify for closed valves or obstructions in boiler piping</li> <li>• Verify that all air has been purged from the system</li> <li>• Verify that wiring is correct</li> </ul>
<b>Flame Failure</b> (Pressing the manual RESET on the TH Control Panel will be required to restart the ignition sequence)	<ul style="list-style-type: none"> <li>• The boiler has failed to ignite the burner after 5 unsuccessful attempts</li> </ul>	<ul style="list-style-type: none"> <li>• Verify that all air has been purged from gas line</li> <li>• Inspect spark electrode and related wiring for damage and connection errors</li> <li>• Verify that the ignition fan speed is set to 3000 RPM through fan diagnostics screen.</li> <li>• Verify that boiler is properly grounded</li> <li>• Verify incoming gas supply pressure and that it coincides with Table 8.</li> <li>• Verify that the vent/ air inlet piping (if equipped) are correctly installed and obstructions are not present.</li> <li>• Verify 24 VAC is being supplied to the gas valve transformer from the TH Controller during ignition. Check wiring from TH Controller, Gas Valve Transformer and Gas Valve Relay. If a signal cannot be detected, the TH Controller needs to be replaced</li> <li>• If 24 VAC is present, check the outlet of the valve to ensure that gas is flowing. With a manometer connected to the outlet pressure tap of the gas valve a negative pressure should be present during pre-purge. When the valve is energized a change in pressure should occur, if no change is detected the gas valve has failed to open or it is passing insufficient amount of gas. If this is an initial startup increase the low fire gas setting by ¼ turn clockwise.</li> <li>• Inspect flame sensor and associated wiring. Replace if necessary</li> <li>• Inspect the burner. Refer to Burner Maintenance in section 10.7</li> <li>• Replace the TH Controller</li> </ul>

SYMPTOM	FAILURE MODE	ANALYSIS
<p><b>Flame Disappears During a Run Cycle</b> (Pressing the manual RESET on the TH Control Panel will be required to restart the ignition sequence)</p>	<ul style="list-style-type: none"> <li>The TH boiler was running and flame signal suddenly disappeared. This condition occurred 3 times.</li> <li>Lockout: 47</li> <li>Alert: 291, 292, 293, 294</li> </ul>	<ul style="list-style-type: none"> <li>Verify that minimum fan speed is greater than 2500 RPM</li> <li>Verify that all air has been purged from gas line</li> <li>Inspect spark electrode and related wiring for damage and connection errors.</li> <li>Verify that boiler is properly grounded</li> <li>Verify incoming gas supply pressure and that it coincides with Table 8.</li> <li>Verify that the gas line connections to the boiler are adequate</li> <li>Verify that the vent/ air inlet piping (if equipped) are correctly installed and obstructions are not present</li> <li>Verify 120 VAC is being supplied to the transformer from the TH Controller during ignition. If a signal cannot be detected, the TH Controller needs to be replaced</li> <li>Verify that 24 VAC is being supplied to the gas valve during ignition. If a signal cannot be detected, the transformer needs to be replaced</li> <li>Inspect flame sensor and associated wiring. Replace if necessary</li> <li>Inspect the burner. Refer to Burner Maintenance in section 10.7</li> <li>Replace the TH Controller if necessary</li> </ul>
<p><b>Noisy Operation</b></p>	<ul style="list-style-type: none"> <li>Supply Gas Issue</li> </ul>	<ul style="list-style-type: none"> <li>Refer to Part 3 Gas Connection in this manual.</li> <li>Natural Gas Pressure should read between 3" w.c. and 14" w.c.</li> <li>L.P. Gas Pressure should be at 11" w.c.</li> </ul>
	<ul style="list-style-type: none"> <li>Air/Gas Mixture Issue</li> </ul>	<ul style="list-style-type: none"> <li>Refer to Gas Valve Adjustment Procedure in section 9.2 of this manual for the proper combustion setting.</li> </ul>
	<ul style="list-style-type: none"> <li>Air Inlet and/or Vent configuration</li> </ul>	<ul style="list-style-type: none"> <li>Refer to Part 2 Air Inlet and Venting</li> </ul>
	<ul style="list-style-type: none"> <li>Dirty/ Damaged Burner</li> </ul>	<ul style="list-style-type: none"> <li>Refer to Burner Maintenance in section 10.7 of this manual for the burner removal and inspection procedure. Clean or replace the burner, if required.</li> </ul>
	<ul style="list-style-type: none"> <li>Air in the piping system</li> </ul>	<ul style="list-style-type: none"> <li>Purge all air from the piping system</li> </ul>
	<ul style="list-style-type: none"> <li>Incorrect Igniter Gap</li> </ul>	<ul style="list-style-type: none"> <li>Check that spark gap is 9/64"</li> </ul>
<p><b>Auto Reset High Limit Trips</b></p>	<ul style="list-style-type: none"> <li>The supply/ outlet temperature has exceeded the setpoint temperature specified.</li> </ul>	<ul style="list-style-type: none"> <li>Verify that the system is full of water and that all air has been properly purged from the system.</li> <li>Verify that the boiler is piped properly. Refer to Piping Diagrams in Section 12 of this manual.</li> <li>Verify that 120VAC is being supplied to the boiler pump on a call for heat. If voltage cannot be detected check wiring.</li> <li>Verify that the pump is circulating when 120VAC is detected. If not, pump impeller may be stuck. Use a flat head screwdriver on face of pump to turn impeller manually</li> <li>If 120VAC is present during a call for heat, but the pump still does not circulate, replace the pump.</li> <li>Replace the main TH Controller if necessary</li> </ul>

SYMPTOM	FAILURE MODE	ANALYSIS
<b>Manual Reset High Limit Trips</b> (Pressing the manual RESET on the TH Control Panel will be required to restart the ignition sequence)	<ul style="list-style-type: none"> <li>Manual Reset Safety High Limit tripped, supply/outlet temperature in excess of 210°F</li> <li>Alert: 309, 310, 311, 312, 313, 314, 315</li> </ul>	<ul style="list-style-type: none"> <li>Verify that the capillary tube is broken. If this is the case, replace Manual Reset High Limit</li> <li>Verify that the system is full of water and that all air has been properly purged from the system.</li> <li>Verify that the boiler is piped properly. Refer to Piping Diagrams in Section 12 of this manual.</li> <li>Verify that 120 VAC is being supplied to the boiler pump on a call for heat. If voltage cannot be detected check wiring.</li> <li>Verify that the pump is circulating when 120 VAC is supplied. If so, pump impeller may be stuck. Use a flat head screwdriver on face of pump to turn impeller manually.</li> <li>If 120 VAC is present during a call for heat, but the pump still does not circulate, replace pump.</li> </ul>
<b>Fan Speed Too Low</b>	<ul style="list-style-type: none"> <li>Actual fan RPM is 30% slower than target fan speed.</li> <li>Alert: 60, 76</li> </ul>	<ul style="list-style-type: none"> <li>Verify wiring connections at the fan and TH Controller.</li> <li>Replace the fan</li> <li>Replace the TH Controller.</li> </ul>
<b>Fan Speed Too High</b>	<ul style="list-style-type: none"> <li>Actual fan RPM is 30% faster than what is required.</li> <li>Alert: 59, 75</li> </ul>	<ul style="list-style-type: none"> <li>Vent/ Air Inlet Lengths exceed the maximum allowed equivalent lengths. Refer to Air Inlet and Venting Section in Part 2 of this manual.</li> <li>Verify that there are no obstructions in the vent/ air inlet pipes or at terminations</li> <li>Verify wiring connections at the fan and TH Controller.</li> <li>Replace the fan</li> <li>Replace the TH Controller.</li> </ul>
<b>Temperature Overshoot</b>	<ul style="list-style-type: none"> <li>Stack temperature has exceeded the limit set on the boiler.</li> <li>Lockout: 82</li> </ul>	<ul style="list-style-type: none"> <li>The stack temperature has exceeded the maximum temperature allowed.</li> <li>Measure the resistance of the flue sensor at room temperature, it should be approximately 10kΩ.</li> </ul>
	<ul style="list-style-type: none"> <li>The supply/outlet temperature has exceeded the setpoint temperature specified.</li> <li>Alert: 79</li> </ul>	<ul style="list-style-type: none"> <li>Verify that the system is full of water and that all air has been properly purged from the system</li> <li>Verify that the boiler is piped properly. Refer to Piping Diagrams in Section 12 of this manual</li> <li>Verify that 120 VAC is being supplied to the heater pump on a call for heat. If voltage cannot be detected check wiring</li> <li>Verify that the pump is circulating when 120 VAC is supplied. If so, pump impeller may be stuck. Use a flat head screwdriver on face of pump to turn impeller manually</li> <li>If 120 VAC is present during a call for heat, but the pump still does not circulate, replace the pump.</li> <li>Replace the TH Controller, if necessary.</li> </ul>
<b>Sensor Not Connected</b>	<ul style="list-style-type: none"> <li>Supply/ Outlet sensor, Alert: 92</li> <li>Return/ Inlet sensor, Alert: 91</li> <li>Flue sensor, Alert: 95</li> <li>DHW sensor, Alert: 93</li> </ul>	<ul style="list-style-type: none"> <li>Verify that the sensors are connected</li> <li>Verify that they are wired correctly.</li> <li>Measure the resistance of the sensors, 10kΩ sensors.</li> <li>Replace the sensor if necessary</li> </ul>
<b>Fan Not Turning</b>	<ul style="list-style-type: none"> <li>Fan refuses to rotate</li> </ul>	<ul style="list-style-type: none"> <li>Check fan power wires</li> <li>Fan signal wires are interchanged</li> <li>Minimum fan speed must be greater than 1500 RPM</li> </ul>
<b>Air Switch</b>	<ul style="list-style-type: none"> <li>Blocked flue error</li> <li>Alert: 67</li> </ul>	<ul style="list-style-type: none"> <li>Air Switch wire(s) is/are loose</li> <li>Air Switch is set too tight, reduce sensitivity by turning screw ¼ turn clockwise.</li> </ul>
<b>Flame Detection is out of Sync</b>	<ul style="list-style-type: none"> <li>Flame detection is present when no visible signs of a flame exist</li> <li>Lockout: 105, 158</li> </ul>	<ul style="list-style-type: none"> <li>Verify supply voltage for proper polarity.</li> <li>Check external wiring for voltage feedback</li> <li>Check internal wiring for proper connections</li> <li>Check the flame sensor and verify that it is clean</li> <li>Replace TH Controller</li> </ul>
<b>Blank Display Screen</b>	<ul style="list-style-type: none"> <li>Blank display screen</li> </ul>	<ul style="list-style-type: none"> <li>Check wire connections from TH Controller to DyanMax display</li> </ul>

### 9.1 SETTING THE CORRECT COMBUSTION

- 1) Switch the main power off to the boiler by placing the toggle switch in the 'OFF' position
- 2) Switch the main power on to the boiler and adjust setpoint so that boiler begins ignition sequence.
- 3) Observe the boiler as it goes through its startup cycle and operates at high fire. This cycle is detailed on Figure 33 in section 11.9 Ignition Cycle.
- 4) Insert the combustion measurement probe into the stack when high fire operation is observed. Check to see that fan is running at maximum fan speed using the Control Panel.
- 5) The combustion values should reside in the range listed in Table 18. If combustion values are not within this range refer to Section 9.2 Gas Valve Adjustment Procedure to correct this issue.

**Table 18: Combustion Values**

	Natural Gas		Propane	
	CO <sub>2</sub>	CO	CO <sub>2</sub>	CO
<b>Max. Fire</b>	8.5% - 9.0%	<100 PPM	9.5% - 10.0%	<100 PPM
<b>Min. Fire</b>	8.0% - 8.5%	<100 PPM	9.0% - 9.5%	<100 PPM

- 6) When the combustion values are satisfied record these values as Camus requires these for warranty purposes.
- 7) Remove the combustion measurement device and switch the main power off to the boiler by placing the toggle switch in the 'OFF' position.
- 8) Replace the flue temperature sensor back to its proper location.

### 9.2 GAS VALVE ADJUSTMENT PROCEDURE

If adjustment of the gas valve is required use the following procedure.

In order to perform adjustments to the gas valve the TH must be firing before proceeding.

TH 082 – 252

**Figure 22: Venturi & Gas Valve Assembly**

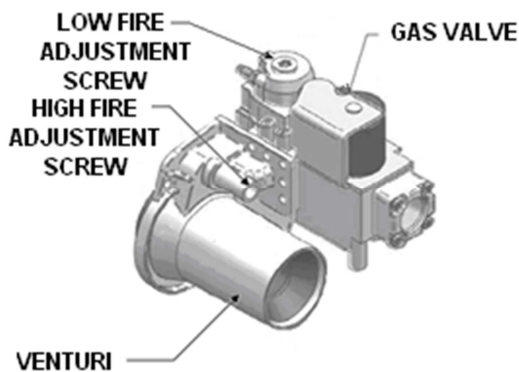

#### To adjust the high-fire setting

Press and hold the 'Next' button for 3 seconds to enter the diagnostic menu on the TH Control Panel. Press 'Next' until the following screen appears:

**Figure 23: High Fire Adjustment Screen**

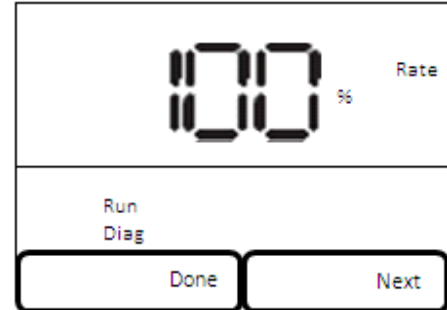

Locate the input adjustment screw on the side of the venturi. Turn the screw 1/8 turn in either way for each adjustment to keep track of the adjustments. After adjusting the screw wait a moment for the combustion levels to stabilize before attempting to make any further adjustments. Continue this procedure until combustion levels are satisfied.

	Increase CO2	Decrease CO2
<b>High Fire Adjustment</b>	 Counter-Clock Wise	 Clockwise

To return to normal operation press 'Done'.

#### To adjust the low fire setting

Press and hold the 'Next' button for 3 seconds to enter the diagnostic menu on the TH Control Panel. Press 'Next' until the following screen appears:

**Figure 24: Low Fire Adjustment Screen**

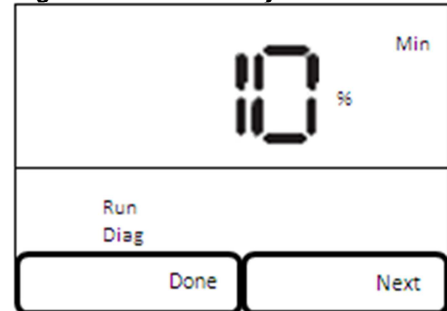

The TH should respond immediately and fire at minimum fan speed. When this is achieved locate the low fire adjustment screw as illustrated in Figure 22. This screw is covered with a cap, which can be removed using a Torx 40 screwdriver. When the correct combustion values are achieved replace the screw cap back on to the gas valve.

	Increase CO2	Decrease CO2
<b>Low Fire Adjustment</b>	 Clockwise	 Counter-Clock Wise

To return to normal operation press 'Done'.

**TH 292 – 392**

**Figure 25: TH 292 – 392 Gas Valve**

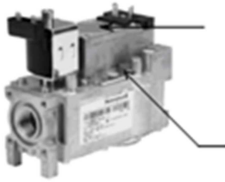

Low-fire air gas ratio adjustment (use Torx 40 for adjustment, clockwise increases CO<sub>2</sub>)

High-fire air gas ratio adjustment (Use slotted screwdriver for adjustment, counter-clockwise increases CO<sub>2</sub>)

To adjust the high-fire setting

Press and hold the 'Next' button for 3 seconds to enter the diagnostic menu on the TH Control Panel. Press 'Next' until the following screen appears:

**Figure 26: High Fire Adjustment Screen**



Locate the high-fire adjustment screw on the top side of the gas valve. The screw can be identified by a red cylinder casing around the screw. Turn the screw 1/8 turn in either way for each adjustment to keep track of the adjustments. After adjusting the screw wait a moment for the combustion levels to stabilize before attempting to make any further adjustments. Continue this procedure until combustion levels are satisfied.

	Increase CO <sub>2</sub>	Decrease CO <sub>2</sub>
<b>High Fire Adjustment</b>	 Counter-Clock Wise	 Clockwise

To return to normal operation press 'Done'.

To adjust the low fire setting

Press and hold the 'Next' button for 3 seconds to enter the diagnostic menu on the TH Control Panel. Press 'Next' until the following screen appears:

**Figure 27: Low Fire Adjustment Screen**

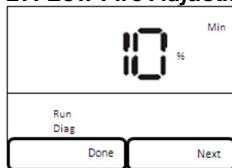

The TH should respond immediately and fire at 1500 RPM. When this is achieved locate the low fire adjustment screw as illustrated in Figure 25. When the correct combustion values are achieved replace the screw cap back on to the gas valve.

	Increase CO <sub>2</sub>	Decrease CO <sub>2</sub>
<b>Low Fire Adjustment</b>	 Clockwise	 Counter-Clock Wise

To return to normal operation press 'Done'.

**TH 502**

**Figure 28: TH 502 Gas Valve**

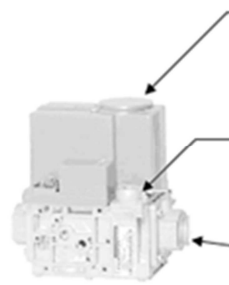

Lift top cover to access high fire air/gas ratio adjustment (use 3mm allen key for adjustment, counter-clockwise increases CO<sub>2</sub>)

Low-fire air/gas ratio adjustment, use slotted screwdriver for adjustment, clockwise increases CO<sub>2</sub>

Gas Inlet

To adjust the high-fire setting

Press and hold the 'Next' button for 3 seconds to enter the diagnostic menu on the TH Control Panel. Press 'Next' until the following screen appears:

**Figure 29: High Fire Adjustment Screen**

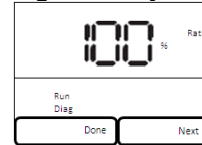

Locate the input adjustment screw on the top side of the gas valve. Turn the screw 1/8 turn in either way for each adjustment to keep track of the adjustments. After adjusting the screw wait a moment for the combustion levels to stabilize before attempting to make any further adjustments. Continue this procedure until combustion levels are satisfied.

	Increase CO <sub>2</sub>	Decrease CO <sub>2</sub>
<b>High Fire Adjustment</b>	 Counter-Clock Wise	 Clockwise

To return to normal operation press 'Done'.

To adjust the low fire setting

Press and hold the 'Next' button for 3 seconds to enter the diagnostic menu on the TH Control Panel. Press 'Next' until the following screen appears:

**Figure 30: Low Fire Adjustment Screen**



The TH should respond immediately and fire at 1500 RPM. When this is achieved locate the low fire adjustment screw as illustrated in Figure 28. When the correct combustion values are achieved replace the screw cap back on to the gas valve.

	Increase CO <sub>2</sub>	Decrease CO <sub>2</sub>
<b>Low Fire Adjustment</b>	 Clockwise	 Counter-Clock Wise

To return to normal operation press 'Done'.

## PART 10 MAINTENANCE

### CAUTION

It is important that all gas appliances be serviced by a qualified technician trained by Camus Hydronics. It is in your own interest and that of safety to ensure that all local codes, and all the "NOTES" and "WARNINGS" in this manual are complied with. To service or adjust this appliance, it is imperative that the serviceman utilize a combustion analyzer to read CO<sub>2</sub> and CO according to Camus Hydronics recommendations.

Listed below are items that must be checked to ensure safe reliable operations. Verify proper operation after servicing.

### 10.1 EXAMINE THE VENTING SYSTEM

Examine the venting system at least once a year. Check more often in the first year to determine inspection interval. Check all joints and pipe connections for tightness, corrosion or deterioration. Flush the condensate drain hose with water to clean. Clean screens in the venting air inlet system as required. Have the entire system, including the venting system, periodically inspected by a qualified service agency.

### 10.2 VISUALLY CHECK MAIN BURNER FLAMES

At each start up after long shutdown periods or at least every six months. A burner view port is located on the combustion chamber front door.

### CAUTION

The area around the burner view port is hot and direct contact could result in burns

**Figure 31: Normal Burner Flame Profile (short dense and blue)**

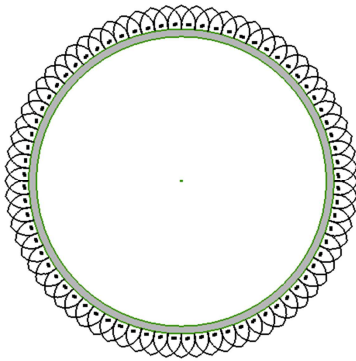

- **Normal Flame:** A normal flame at 100% of burner input is blue, with a well defined flame and no flame lifting.
- **Yellow Tip:** Yellow tipping can be caused by blockage or partial obstruction of air flow to the burner.
- **Yellow Flames:** Yellow flames can be caused by blockage of primary air flow to the burner or excessive gas input. This condition **MUST** be corrected immediately.

If improper flame is observed, examine the venting system; ensure proper gas supply and adequate supply of combustion and ventilation air.

## 10.3 CLEANING BOILER HEAT EXCHANGER

**Figure 32: Heat Exchanger & Burner Assembly**

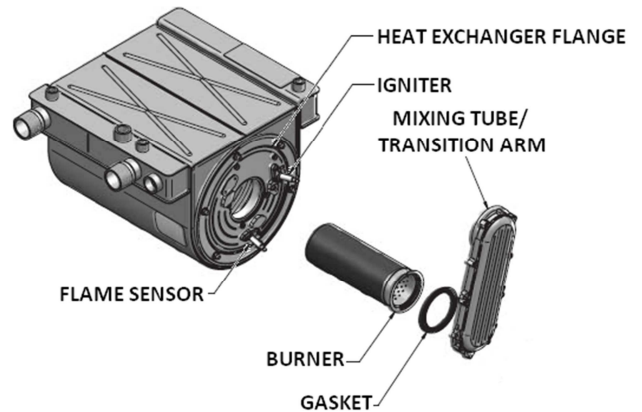

- 1) Shut down boiler:
  - a) Turn the main power off to the boiler
  - b) Shut off gas supply at the main manual valve in the gas piping of the main appliance
  - c) **DO NOT** drain the boiler unless it will be exposed to freezing temperatures. If using antifreeze prevention fluid in the heat exchanger, **DO NOT** drain.
- 2) Allow time for the boiler to cool to room temperature if it has been firing.
- 3) Remove the upper sheetmetal jacket.
- 4) Remove igniter and flame sensor electrodes. If necessary, clean with steel wool. **DO NOT** use sandpaper.
- 5) Remove the fan/ mixing tube assembly from the heat exchanger door.
- 6) Remove burner.
- 7) Examine burner and clean if required as per 10.7.1.
- 8) Examine heat exchanger surfaces to determine if cleaning is required. If cleaning is required remove the (6) nuts fastening the heat exchanger flange from the heat exchanger.
- 9) Use a vacuum cleaner to remove any debris that has collected on the heat exchanger surfaces. **DO NOT** use any type of solvent.
- 10) Finish cleaning by wiping down the boiler heating surfaces with a clean, damp cloth.
- 11) Re-install the heat exchanger door by evenly torquing down the (6) nuts to 3 ft-lbs, burner, igniter and flame sensor, and fan/ mixing tube assembly. Fasten the nuts back to the heat exchanger assembly.
- 12) Re-connect the fan assembly to the boiler mixing tube.

### NOTE

All gaskets on disassembled components must be replaced with new gaskets/sealant on re-assembly, if required. Gasket kits are available from the factory



### **CAUTION**

When the vent system is disconnected for any reason it must be reassembled and resealed according to vent manufacturer's instruction

## **10.4 CONDENSATE TREATMENT**

Condensate occurs when the products of combustion are cooled below their dew point in the heat transfer process. The liquid condensate formed from this high efficiency heat transfer process is mildly acidic. The condensate will typically have a pH ranging from 4.0 to 5.0 as it is discharged from the condensate drain of the appliance. The condensate collection box where the condensate is collected is constructed of a non-corrosive plastic. All materials external to the appliance in contact with the condensate must be corrosion resistant. Condensate must be able to flow freely from the appliance. All condensate flow is accomplished by gravity requiring a minimum downward slope of 1/4" per foot (21mm/m) to ensure proper flow to a suitable drain. A neutralizer box is mounted inside each TH. All condensate piping and connections must be easily accessible for routine maintenance and inspection. Use solid piping when running condensate line across the floor. Check neutralized pH level regularly or as required by local jurisdiction. Replace neutralizer medium as required.

### **10.4.1 Condensate Volume**

There are several factors affecting amount of condensation created by the appliance, however for rough approximation use.

Condensation Volume, US Gallon/Hr = Input, MBH/1000 x 5.0

Many codes will require the acidic condensate to be neutralized before it can be placed in a drain system. A neutralizer to control the pH of the liquid discharged to a drain system is provided with every TH boiler. The neutralizer consists of an industrial grade, non-corrosive plastic reservoir for collection of the condensate. The condensate collects in the reservoir where it is in direct contact with calcium carbonate neutralizer medium. As the reservoir fills, it provides an extended residence time to neutralize the condensate. Residency time in the neutralizer reservoir allows time for the pH to be raised. Prime the neutralizer reservoir with 1 litre of water.

As the condensate migrates through the reservoir in typical applications the pH is controlled to a range of 5.5 to 6.0 before exiting the system. Always check with local codes for specific requirements.

## **10.5 IGNITER AND FLAME SENSOR ELECTRODES**

The direct spark igniter is to be checked at every service interval. Clean the direct spark igniter as required to maintain peak ignition efficiency.

- 1) Turn off main electrical power to the appliance.
- 2) Turn off main manual gas shutoff to the appliance.
- 3) Locate the direct spark igniter and flame sensor.
- 4) Disconnect the power lead to the direct spark igniter and flame sensor
- 5) Loosen and remove the two (2) torx screws that hold the igniter and flame sensor to the heat exchanger flange.

- 6) Pull the igniter horizontally out of the heat exchanger flange. Use care, do not hit or break the igniter leads.
- 7) Remove any debris that has accumulated on the electrodes using steel wool. If the electrodes cannot be cleaned to their original appearance, replacements are needed. Do not use sand-paper since this will contaminate the surface.
- 8) Check that the igniter and flame sensor gaskets are still in good condition (no tears or seams). If the gaskets are in good condition the electrodes can be re-installed back to the heat exchanger flange.
- 9) Check that the igniter gap is 9/64".

## **10.6 CHECK IGNITER GROUND WIRING**

- 1) Inspect boiler ground wire from the heat exchanger flange to J1-3 of the TH Controller. Check boiler ground wire continuity.
- 2) Verify that all wiring is in good condition and is securely anchored.

## **10.7 BURNER MAINTENANCE**

The burner should be removed for inspection and cleaning on an annual basis. An appliance installed in a dust or dirt contaminated environment will require inspection and cleaning on a more frequent schedule. The fan assisted combustion process may force airborne dust and dirt contaminants, contained in the combustion air, into the burner. With sustained operation, non-combustible contaminants may reduce burner port area, reduce burner input or cause non-warrantable damage to the burner. Never operate this appliance during construction.

Airborne contaminants such as dust, dirt, concrete dust or dry wall dust can be drawn into the burner with the combustion air and block the burner port area.

### **10.7.1 Burner Removal and Cleaning**

Access to the burner will require the following steps:

- Turn off main electrical power to the appliance.
- Turn off main manual gas shutoff to the appliance
- Remove the front cover.
- Disconnect the gas supply connection to the fan inlet.
- Disconnect the fan motor power wires at the harness.
- Remove the direct spark igniter and the flame sensor.
- Remove the three (3) T-25 screws holding the front burner flange in place to gain access to the burner.
- The burner can now be pulled horizontally out of the heat exchanger cavity.
- Use care to prevent damage to the knitted metal fiber of the burner surface.
- Wash the burner with water, such as a garden hose. Never wipe or brush the surface of the burner.
- For optimal results immerse the burner port area in a solution of dishwashing detergent and hot water. **DO NOT** use chlorine based solvents or cleaning agents on the burner. Allow the burner to remain in the solution for a short period of time to remove, dust, dirt and oil or grease laden contaminants.

- Rinse the burner thoroughly with clean water to remove any residue from the detergent cleaner
- The burner should be air dried after removal from the cleaning solution and rinsing.
- Check all gaskets and replace as necessary. Gaskets affected by heat will not reseal properly and must be replaced.
- Replace the burner in the reverse order that it was removed.

**NOTE**

When the combustion air fan is removed for any reason, the inlet to the burner must be covered to prevent further foreign objects from falling into the burner. Always look inside the burner to check for dents. Do not place a burner back into operation if the inner distribution screen has been dented during the service operation, call the factory for recommendations. Use care when removing and handling the burner, Sharp objects or impact may damage or tear the metal fiber surface rendering the burner unfit for service.

**10.8 REMOVAL OF COMBUSTION CHAMBER LINING**

The combustion chamber insulation in this appliance contains ceramic fiber material. Ceramic fibers can be converted to cristobalite in very high temperature applications. The International Agency for Research on Cancer (IARC) has concluded, "Crystalline silica in this form of quartz or cristobalite from occupational sources is carcinogenic to humans (Group 1)". Normal operating temperatures in this appliance are below the level to convert ceramic fibers to cristobalite. Abnormal operating conditions would have to be created to convert the ceramic fibers in this appliance to cristobalite.

The ceramic fiber material used in this appliance is an irritant; when handling or replacing the ceramic materials it is advisable that the installer follow these safety guidelines.

- Avoid breathing dust and contact with skin and eyes.
  - Use NIOSH certified dust respirator (N95). This type of respirator is based on the OSHA requirements for cristobalite at the time this documentation was written. Other types of respirators may be needed depending on the job site conditions. Current NIOSH recommendations can be found on the NIOSH website at <http://www.cdc.gov/niosh/homepage.html>. NIOSH approved respirators, manufacturers, and phone numbers are also listed on this website.
  - Wear long-sleeved, loose fitting clothing, gloves, and eye protection
- Apply enough water to the combustion chamber lining to prevent airborne dust.
- Remove the combustion chamber lining from the water heater and place it in a plastic bag for disposal.
- Wash potentially contaminated clothes separately from other clothing. Rinse clothes washer thoroughly.

**NIOSH stated First Aid**

- Eye: Irrigate immediately
- Breathing: Fresh air

**10.9 COMBUSTION AND VENTILATION AIR**

Check frequently to be sure that the flow of combustion air to the appliance is not obstructed unless air is piped directly to the heater. Combustion air must be provided to the mechanical room with openings sized per the requirements of the current B149 or National Fuel Gas Code. The TH is setup to allow outdoor combustion air to be connected directly to the appliance.

**10.10 CONTROL CIRCUIT VOLTAGE**

This appliance uses a transformer to supply a low voltage control circuit. The voltage on the secondary side should be 24 to 28VAC when measured with a voltmeter. A secondary voltage of 21VAC or less supplied to 24VAC components may cause operational problems.

**10.11 COMBUSTIBLE MATERIALS**

**CAUTION**

Keep appliance clear from combustible materials; do not store **GASOLINE** and other flammable vapors and liquids in the proximity of the appliance.

**10.12 FREEZE PROTECTION FOR INDOOR & OUTDOOR INSTALLATIONS**

Installations are not recommended in areas where the danger of freezing exists. Proper freeze protection must be provided for appliances installed outdoors, in unheated mechanical rooms or where temperatures may drop to the freezing point or lower. If freeze protection is not provided for the system, a low ambient temperature alarm is recommended for the mechanical room. Damage to the appliance by freezing is non-warrantable.

- **Location** - Heating boilers, hot water supply boilers or water heaters must be located in a room having a temperature of at least 40°F (5°C).
- **Caution** - A mechanical room operating under a negative pressure may experience a downdraft in the flue of an appliance that is not firing. The cold outside air may be pulled down the flue and freeze a heat exchanger. This condition must be corrected to provide adequate freeze protection.
- **Shut-down and draining** - If for any reason, the unit is to be shut off in a space where danger of freezing exists, the following precautionary measures must be taken:
  - Shut off gas supply.
  - Shut off water supply.
  - Shut off electrical supply.
  - Drain the main exchanger and tank completely.
  - Ensure that the pump and connecting piping are fully drained.



## PART 11 INSTALLATIONS

### WARNING

Before starting the boiler, smell near the floor and around the boiler for any gas odours or any unusual odour. Remove the stainless steel jacket and smell the interior of the boiler. If there is any sign of a gas leak, do not proceed with startup. Repair all the leaks before attempting to start the boiler.

### WARNING

Propane boilers ONLY – Your local propane supplier adds an odorant to the propane gas to allow for propane gas leak detection. In some cases, the added odorant can fade and the gas may not give off any noticeable odour. Before startup have the local propane supplier check for the correct odorant level in the gas.

### 11.1 CHECKING THE INSTALLATION

- Inspect the connections for water, gas and electricity.
- Inlet gas pressure must be a minimum of 3" W.C. for natural gas and 11" W.C. for propane.
- With the heater off, open the main gas supply valve and vent the trapped air from the piping leading to the heater. Confirm that all gas connections to the heater are tight and that there are no missing test plugs.

Refer to Section 9.1 Setting the Correct Combustion of the manual for recommendations on setting combustion characteristics

### 11.2 CHECKING THE CONSTRUCTION

- Check the boiler wiring to see that it agrees with the wiring diagram supplied.
- Confirm that all terminal strips and field connections are identified.
- Confirm that the TH Controller control is set in the proper mode. In remote mode an external controller determines the set point and the stage contacts on the TH Controller are always closed. Auto reset limits are fixed in all Modes.
- With the heater running, check for flue gas leaks along the inner cabinet joints and around the flue outlet.
- Repair any leaks prior to proceeding to the next step.
- At the factory, adjustments were made to achieve proper input and acceptable burner performance at full input and at minimum input.

### 11.3 INSPECT & RECHARGE CONDENSATE COLLECTION/NEUTRALIZING RESERVOIR

- 1) Inspect the condensate reservoir in the TH, making sure the collection box is intact.
- 2) Remove screw holding lid on to condensate collection box. Remove lid from the condensate collection box
- 3) Examine neutralizer medium and refill as necessary with fresh medium
- 4) Fill with fresh water until the water begins to flow out of drain
- 5) Re-install the lid and hold-down screw on the condensate collection box.

### WARNING

The condensate collection box must be filled with water to prevent flue gas emissions from escaping during boiler operation.

### CAUTION

A leak in a boiler "System" will cause the fill system to introduce fresh water constantly, which may cause the tubes to accumulate a line/scale build up. Lime/scale buildup leading to heat exchanger failure is **NOT** covered by warranty.

### 11.4 WATER CONNECTIONS

System pipe size must be in accordance with Table 9 (depending on model). Connection sizes at the heater are given in Tables 4. Any reduction in recommended pipe size may decrease flow resulting in high temperature rise across the heat exchanger, boiler noise, flashing to steam and non-warrantable heat exchanger damage.

### 11.5 SUMMARY

#### a) Typical Heater Installations

##### General Plumbing Rules

- 1) Check all local codes.
- 2) For serviceability, always install unions.
- 3) Always pipe pressure relief valve to an open drain.
- 4) Locate system air vents at highest point of system.
- 5) Expansion tank must be installed near the heater and on the suction side of the system pump.
- 6) Support all water piping.
- 7) Place drip pan underneath heater. (if required)

#### b) Placing the Heater in Operation

##### Pre-Start Check List

- 1) Review the location of the heater, clearances from combustible surfaces and available service clearances.
- 2) Review Part 2 Venting. Ensure that all vent components are fabricated from the correct category of materials with adequate clearance from combustibles.
- 3) Fill the condensate collector with fresh water until water begins to pour out the drain.
- 4) Ensure that the heater condensate drain and all vent system condensate drains are properly routed to an acceptable floor drain.
- 5) Review the vent termination point for proper location and clearances.
- 6) If a separate combustion air pipe is used, ensure that it is properly sized, sealed and terminated.
- 7) Review the water piping from the heater to the system. The heater must be installed in a primary/ secondary piping system. Review the diameter and equivalent length of the installed piping to and from the heater to ensure proper flow.
- 8) Ensure that a properly sized system pump is installed with an expansion tank.
- 9) Check system pressure. Ensure a minimum of 18-20 PSIG with the system hot and not more than 90% of the rated pressure of the relief valve.

- 10) Review the installed gas piping from the meter to the boiler. Ensure that the gas pipe, meter and any regulators are adequately sized.
- 11) Review the field wiring and electrical service for the heater controls. Ensure that the electrical service(s) is adequately sized.

#### Heater Set-Up

- 1) Ensure that the heater and piping system are full of water. Bleed all air from the pump housing and secondary loop.
- 2) Check system for any water leaks.
- 3) Check system for installation of glycol or water treatment where required. Where glycol has been used to maintain the temperature rise across the appliance confirm that the recommended flow for pure water has been increased by 15% and the head loss by 20%.

#### Boiler Operational Checks

- 1) Turn the heater main power switch to the "ON" position.
- 2) Verify operation of the display on the front panel.
- 3) Program the adjustable points.
- 4) Push the reset button if a lockout error is displayed.
- 5) Install a manometer on the gas supply to the heater and verify minimum gas supply pressure as the burner fires at 100% of rated input.
- 6) Verify operation of safeties as necessary (low water cut-off, high limit, gas pressure, etc.).

#### Heater Operation

- 1) Appliance should begin the start-up process for the sequence of operation.
- 2) The boiler will fire at 50% of rated input on initial start-up and adjust input as required to meet system demand.
- 3) Based on system demand, the appliance will modulate accordingly.
- 4) As system demand is satisfied, the burner will fire at minimum fire for the given demand and the heater will cycle off when the demand ceases or is interrupted. When this occurs the combustion air fan will decelerate at a pre-programmed rate before the appliance shuts down.

### 11.6 TEMPERATURE RISE AT FULL FIRING RATE

- 1) The pump must run continuously when the burner is firing.
- 2) With the pump running and the burner in the water heater in the off cycle, the Return/Inlet temperature and Supply/Outlet temperature readings on the TH Control Panel should read approximately the same temperatures.
- 3) Turn the hot water heater on and allow time for the temperature to stabilize. Check the temperature rise when the burner is firing at 100% of rated input.
- 4) Compare the temperature rise on the Control Panel with the required temperature rise at the required flow rate on Table 19.
- 5) Should adjustment be needed, proceed as follows:

- 6) The TH uses stainless steel heat exchanger tubes which are not sensitive to higher water velocity. If temperature rise is lower than anticipated it is not necessary to reduce flow.

**If the temperature rise is too high, the water velocity is too low. Adjust as follows:**

- 1) Check for flow restrictions. Check for debris in strainers
- 2) Check the pump to be sure it is running properly and that the pump motor is running in the proper direction.
- 3) Common manifold piping for multiple unit installations will require larger minimum pipe sizes.

The required temperature rise and the recommended pump size are based on the heating of potable water with normal hardness within a typical range of 7.5 to 17.0 grains per gallon. Consult the factory when heating potable water exceeding these specifications. Damage to the heat exchanger as a result of scaling or corrosive water conditions in non-warrantable.

**Table 19: Temperature Rise Across Heat Exchanger**

MODEL [BTU/hr]	TEMPERATURE RISE ACROSS HEAT EXCHANGER	
	20°F (11.1°C)	
	USGPM	ΔP-Ft.
80,000	7.5	11.5
100,000	9.4	26.9
150,000	14.0	27.8
199,000	19.2	25.9
250,000	23.5	28.3
299,000	28.8	25.8
399,000	38.4	23.9
500,000	48.6	29.4

CAUTION
Temperature rise cannot be adjusted when the burner is firing at less than 100% of input rate.
CAUTION
Adequate care <b>MUST</b> be taken to prevent potential scald injury when storing water at 140°F (60°C) and hotter.

WARNING
Should overheating occur or the gas supply fail to shut off, do not turn off or disconnect the electrical supply to the pump, instead, shut off the gas supply at a location external to the appliance

### 11.7 SETTING THE CORRECT COMBUSTION

Refer to Section 9.1 Setting the Correct Combustion.

### 11.8 APPLIANCE

- Remove manometers and tighten test port screws.
- Fill out start up report for each heater. Be sure to record all settings and readings. Retain a copy of report for future reference.
- Start up is now complete and heater may be placed into service.

### 11.9 IGNITION CYCLE

The ignition cycle is shown in the table below. The values are the default factory settings.

**Figure 33: TH Ignition Cycle**

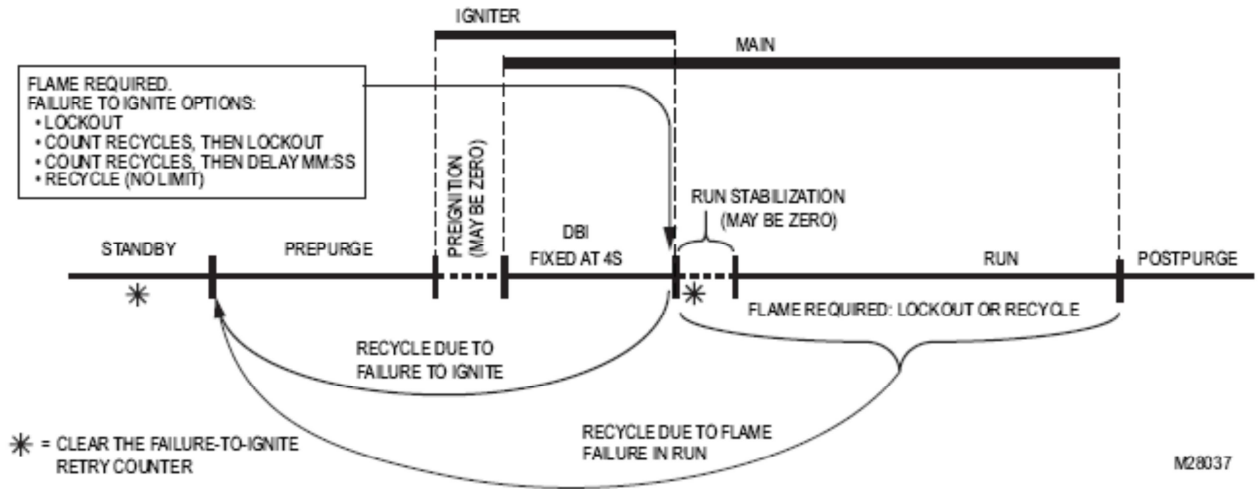

## PART 12 SUGGESTED PIPING DIAGRAMS

Figure 34: Dedicated DHW Suggested Piping Arrangement

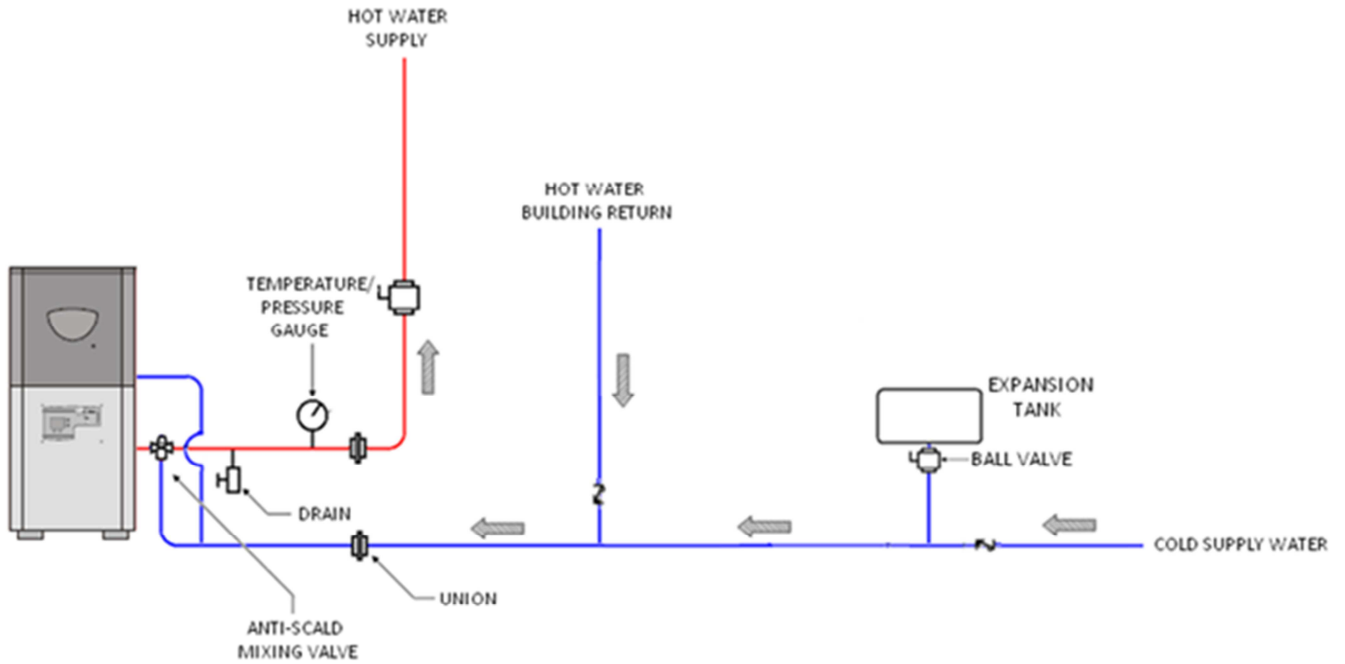
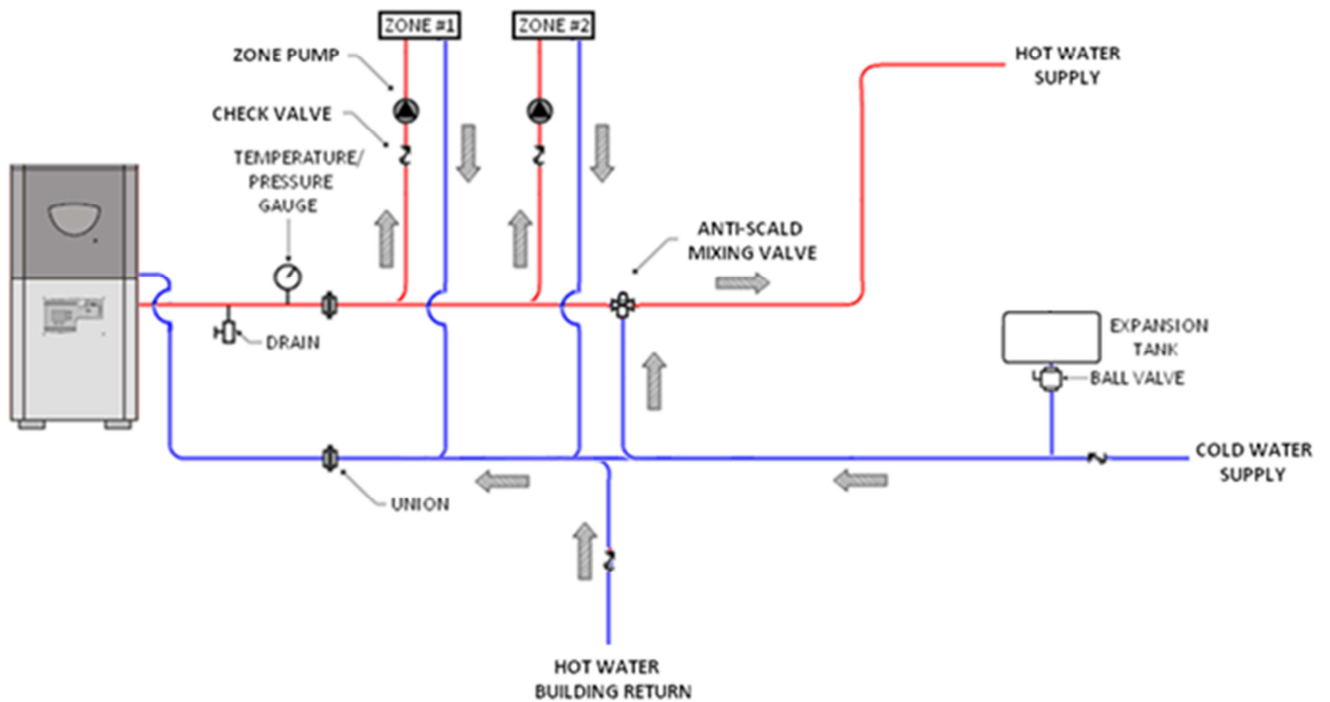
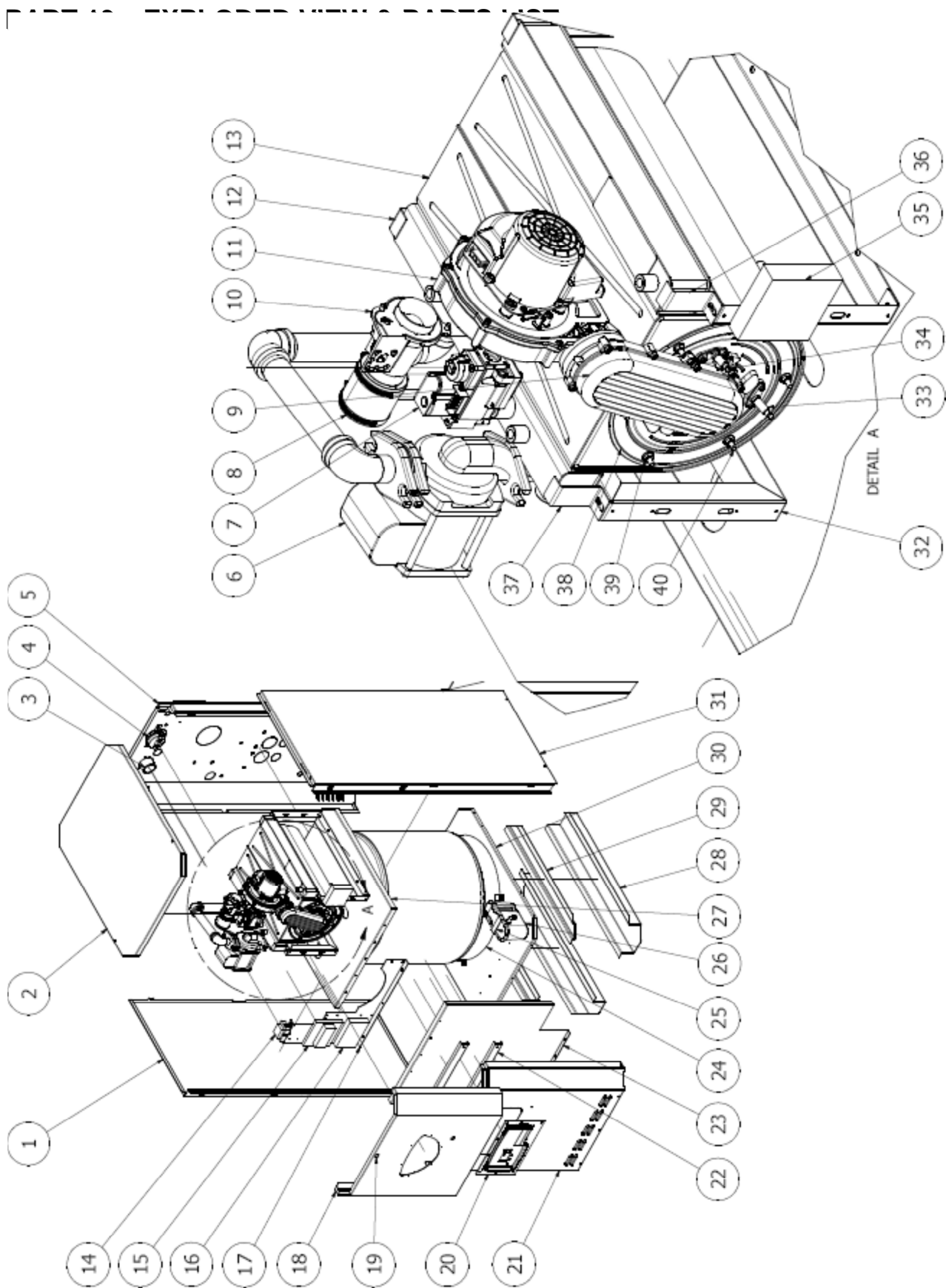

Figure 35: Combination Application Suggested Piping Arrangement



NOTE: HEATING ZONE PUMPS MUST BE EXERCISED ON A REGULAR BASIS DURING SUMMER MONTHS WHEN HEATING IS NOT REQUIRED.



Ref #	Name of Part	Part ID	ALL	82	102	152	202	252	292	392	502	
1	Outer Jacket - Left	14-5625		X	X	X						
		14-5605					X	X				
2	Outer Jacket – Top Cover	14-5629		X	X	X						
		14-5609					X	X	X	X	X	
3	Air Intake Adapter	44-0008		X	X	X	X	X				
		300704							X	X		
		44-0010										X
4	Blocked Flue Switch	8021205256	X									
5	Outer Jacket - Back	14-5604		X	X	X	X	X				
6	Pump (Armstrong)	E7B		X	X							
		E9B				X	X	X				
		E12B								X	X	
		H54B										X
		E33B								X	X	X
	Pump (Wilo)	Star 16 BFX			X							
		Star 30 BU				X						
		TOP S 1.5x20B					X					
		TOP S 1.5x30B						X		X	X	
		TOP S 1.5x40B							X			X
7	Gas Valve	VK8115V1036		X	X	X	X	X				
		VR8615B1044							X	X		
		V8730C1015										X
8	Expandable Air Inlet Adapter	14-0379		X	X	X	X	X	X	X		
		44-0009										X
9	Transition Arm	GM20-70-020-01		X	X	X	X	X	X	X		
		GM10-15-997-03										
10	Venturi	459000-444-003		X	X							
		459000-444-001				X						
		459000-446-051					X	X				
		45900450-010								X	X	
		VMU300A1046										X
11	Combustion Fan	55667.11221		X	X							
		55667.21120				X						
		55667.21080					X	X				
		55667.21200							X	X		
		55667.14002										X
12	Rear Bracket	14-5411		X	X	X						
		14-5520-20-25					X	X				
13	Heat Exchanger	4+1		X	X							
		5 + 2				X						
		8 + 4					X	X				
		10 + 6							X			
		15 + 8								X		
		18 + 10										X
14	40VA Transformer	HCT-01E0BB06	X									
15	Pump Relay	LY1F	X									
16	Ignition Control	R7910B1009	X									
17	Control Panel	14-5614		X	X	X	X	X				



Ref #	Name of Part	Part ID	ALL	82	102	152	202	252	292	392	502
18	Outer Jacket – Front Top	14-5608		X	X	X	X	X			
		14-5648							X	X	X
19	¼ Turn Lock	Floor Mount	X								
20	Bezel	15-6001-H	X								
21	Outer Jacket – Front Bottom	14-5607	X								
22	Bezel Support	14-5615	X								
23	Inner Jacket – Front	14-5610	X								
24	SS Tank	15-0021		X	X	X					
		15-0014					X	X	X	X	X
25	Bracket for Neutralizer Box	14-5525	X								
26	Condensate Neutralizer Box	15-6010	X								
27	HX Base Support	14-5631		X	X	X					
		14-5611					X	X	X	X	X
28	Support Leg	14-5621		X	X	X					
		14-5601					X	X	X	X	X
29	Stiffner under Support Leg	14-5622		X	X	X					
		14-5602					X	X	X	X	X
30	Base	14-5623		X	X	X					
		14-5603					X	X	X	X	X
31	Outer Jacket – Right	14-5626		X	X	X					
		14-5606					X	X	X	X	X
32	HX Support	14-5632		X	X	X					
		14-5612					X	X			
33	Flame Sensor	GM10-35-109	X								
34	Igniter	GM10-35-108	X								
35	Current Transformer	CSS-0A-200-001	X								
36	Right Bracket	14-5513-20-25	X								
37	Left Bracket	14-5410		X	X						
		14-5518-20-25				X	X	X	X	X	X
38	Heat Exchanger Flange	GM20-65-028-01		X	X	X					
		GM20-65-033-01					X	X	X	X	X
39	Heat Exchanger Flange Nuts	GM10-05-012	X								
40	Igniter/Flame Sensor Screws	GM10-05-020	X								
41	Igniter Gasket	GM10-25-018	X								
42	Flame Sensor Gasket	GM10-25-004	X								
43	Burner Refractory	GM10-25-098-01		X	X	X					
		GM10-25-107					X	X	X	X	X
44	Automatic Air Vent	FV-4M1	X								
45	Flue Sensor	NTC-SENSOR-003	X								
46	Sensor Wire	CABLE HARNESS	X								
52	TH Fan Discharge Orifice	14-0377		X	X	X	X	X			

Ref #	Name of Part	Part ID	ALL	82	102	152	202	252	292	392	502
53	Expandable Air Inlet Adapter w/o Pressure Test Point	1056-22		X	X	X	X	X	X	X	
		1056-33									X
47	Burner	80,000 BTU		X							
		100,000 BTU			X						
		150,000 BTU					X				
		199,000 BTU						X			
		250,000 BTU							X		
		299,000 BTU								X	
		399,000 BTU									X
48	Burner Gasket	GM10-25-074-09	X								
49	Gas Valve Elbow	45900400-132/B		X	X	X	X	X			
		45900400-144/B							X	X	X
50	Gas Valve Wire Harness	45900441-015B		X	X	X	X	X			
		45900400-144/B							X	X	
51	½" Fire Valve	USA0509101T		X	X	X	X	X			
52	Flex Pipe	2" Diameter		X	X	X	X	X	X	X	
		3" Diameter									X
53	Metal Latch	6521-00-0551-YT	X								
54	Strike	7800-02									
55	On/Off Switch	W51A152A	X								
56	Display	S7910B1006	X								
57	Gas Valve Relay	T9CP1A54-24	X								
58	TH Wire Harness	77-0037	X								
	Not shown in Exploded View										

# PART 14 ELECTRICAL DIAGRAMS

## 14.1 TH 82- 502 INTERNAL WIRING DIAGRAM

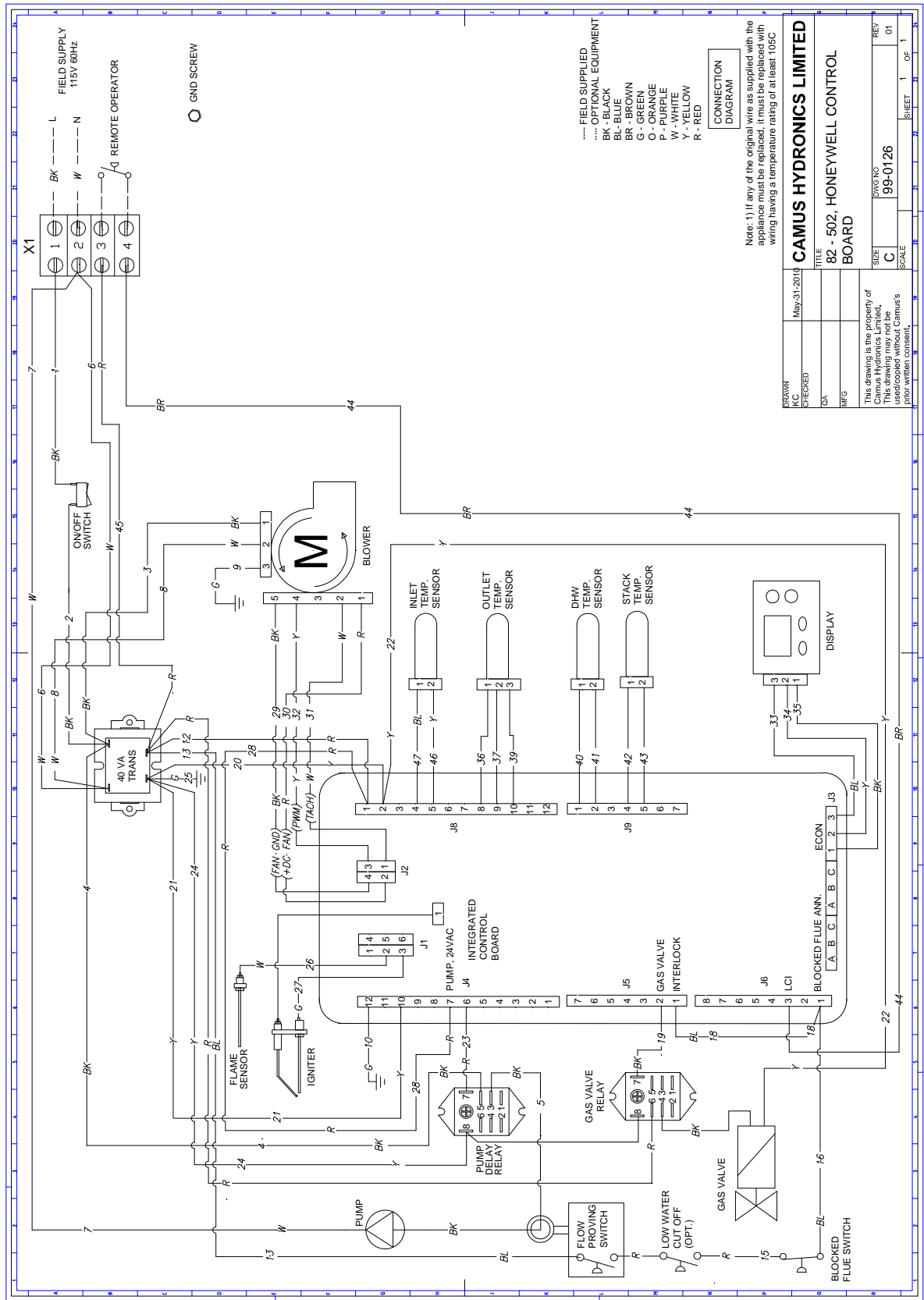

#### 14.2 DETAILED CONNECTOR DESCRIPTION

Connector	Pin #	Connector Description
J1		Flame Sensor and Ground
	1	Not Used
	2	Flame Sensor
	3	Ground
	4	Not Used
	5	
	6	
J2		Fan PWM Modulation
	1	Fan Tachometer Signal
	2	Fan Signal, +DC
	3	Fan Pulse Width Modulation (PWM) Signal
	4	Fan Signal, -DC
J3		On-Board Pump
	1	Display, Data Send
	2	Display, Data Receive
	3	Display, Common
J4		24VAC Power
	1-9	Not Used
	10	24VAC
	11	Not Used
	12	Ground
J5		Gas Valve, Safety String
	1	Safety String, Return
	2	Gas Valve, 24VAC
	3-7	Not Used
J6		Safety Annunciator
	1	Blocked Flue Switch
	2	Flow Switch
	3	Flow Switch
	4-8	Not Used

Connector	Pin #	Connector Description	
J8		24VAC Power, Outlet Sensor	
	1	24VAC	
	2	24 VAC Return	
	3	Remote Operator	
	4-7	Not Used	
	8	Outlet Sensor & High Limit	
	9		
	10		
		11-12	Not Used
	J9	1	Inlet (DHW) Sensor
2		Not Used	
3			
4			
5		Outlet Sensor	
T1		Spark Igniter	

# CONDENSING BOILER LIMITED WARRANTY

Camus Hydronics Limited ("Camus") extends the following LIMITED WARRANTY to the owner of this appliance, provided that the product has been installed and operated in accordance with the Installation Manual provided with the equipment. Camus will furnish a replacement for, or at Camus option repair, any part that within the period specified below, shall fail in normal use and service at its original installation location due to any defect in workmanship, material or design. The repaired or replacement part will be warranted for only the unexpired portion of the original warranty.

## THIS LIMITED WARRANTY DOES NOT COVER

1. Failure to properly install, operate or maintain the equipment in accordance with Camus' manual
2. Abuse, alteration, accident, fire, flood, foundation problems and the like
3. Sediment or lime build-up, freezing, or other conditions causing inadequate water circulation
4. Pitting and erosion caused by high water velocity;
5. Failure of connected systems devices, such as pump or controller
6. Use of non-factory authorized accessories or other components in conjunction with the system;
7. Failing to eliminate air from, or replenish water in, the connected water system
8. Chemical contamination of combustion air or use of chemical additives to water
9. Production of noise, odours, discolouration or rusty water
10. Damage to surroundings or property caused by leakage or malfunction
11. All labour costs associated with the replacement and/or repair of the unit
12. Any failed component of the hydronic system not manufactured as part of the boiler.

## HEAT EXCHANGER

If within TWELVE years after initial installation of the appliance, a heat exchanger shall prove upon examination by Camus to be defective in material, thermal shock, leakage or workmanship, Camus will exchange or repair such part or portion on the following pro rated limited warranty

Years into Warranty	% of List Price
8	30
9	40
10	50
11	60
12	70

This term is reduced to SIX years if the appliance is used for other than hydronic space heating. Heat Exchanger shall be warranted for (20) years from date of installation against "Thermal Shock" (excluded, however, if caused by appliance operation at large changes exceeding 150°F between the water temperature at inlet and appliance temperature or operating at temperatures exceeding 230°F).

## BURNER

If within FIVE years after initial installation of the appliance, a burner shall prove upon examination by Camus to be defective in material or workmanship, Camus will exchange or repair such part or portion.

## STAINLESS STEEL STORAGE TANK

If within TEN years after initial installation of the appliance, a stainless steel storage tank shall prove upon examination by Camus to be defective in material or workmanship, Camus will exchange or repair such part or portion.

## ANY OTHER PART

If any other part fails within one (1) year after installation, or eighteen (18) months from date of factory shipment based on Camus' records, whichever comes first. Camus will furnish a replacement or repair that part. Replacement parts will be shipped f.o.b. our factory.

## DURATION OF LIMITED WARRANTY

Any limited warranty, including the warranty of merchantability imposed on the sale of the boiler under the laws of the state or province of sale are limited in duration to one year from date of original installation.

## STATE LAW & LIMITED WARRANTY

*Some states or provinces do not allow:*

- a) Limitations on how long an implied warranty lasts
  - b) Limitations on incidental or consequential damages.
- The listed limitations may or may not apply to you. This warranty gives you specific legal rights, and you may also have other rights which may vary from state to state and province to province.

## CONDITIONS

*We will not:*

- a) Repair or replace any boiler, or part, subject to conditions outlined in 'This Limited Warranty Does Not Cover'
- b) Reimburse any costs associated with repair and/or replacement
- c) Replace and/or repair any boiler without complete model number/serial number
- d) Replace any boiler without prior receipt of actual rating plate from the appliance.

## HOW TO MAKE A CLAIM

Any claim under this warranty shall be made directly to Camus Hydronics Limited Canadian Head Office

## SERVICE LABOR RESPONSIBILITY

Camus shall not be responsible for any labour expenses to service, repair or replace the components supplied. Such costs are the responsibility of the owner.

## DISCLAIMERS

Camus shall not be responsible for any water damage. Provisions should be made that in the event of a water/appliance or fitting leak, the resulting flow of water will not cause damage to its surroundings.

Name of Owner			
Name of Dealer			
Address			
Model No.			
Serial #:			
Date of Installation:		Date of Initial Operation:	

6226 Netherhart Road, Mississauga, Ontario, L5T 1B7, CANADA

CAMUS Hydronics is a manufacturer of replacement parts for most copper finned water heaters and heating boilers as well as a



The CAMUS CERTIFIED! Seal assures you that Reliability, Efficiency & serviceability are built into every single unit! For more information

supplier of specialty HVAC products. Our service line is open 24 hours, 7 days a week!

on our innovative products from CAMUS Hydronics Limited, call 905-696-7800 today.



**CAMUS HYDRONICS LTD.**

**6226 Netherhart Road, Mississauga, Ontario L5T 1B7**

**TEL: 905-696-7800 FAX: 905-696-8801**