

INSTALLATION OPERATION AND SERVICE MANUAL

   	<p>GAS FIRED WALL HUNG & FLOOR MOUNT RESIDENTIAL COMMERCIAL STAINLESS STEEL BOILERS</p>  <p>DynaMax HS SERIES</p> <p>HYDRONIC HEATING <i>Models; DMH081, 101, 151, 201, 251, 211, 261, 291, 391, 501, 601, 701, 801</i></p> <p>HOT WATER SUPPLY <i>Models; DMW082, 102, 152, 202, 252, 212, 262, 292, 392, 502, 602, 702, 802</i></p> <p>COMBINATION HEATING/HOT WATER SUPPLY <i>Models; DMC083, 103, 153, 203, 253, 213, 263, 293, 393, 503, 603, 703, 803</i></p>	  
---	--	---

WARNING:
If the information in these instructions is not followed exactly, a fire or explosion may result causing property damage, personal injury or death

Do not store or use gasoline or other flammable vapours and liquids in the vicinity of this or any other appliance.

WHAT TO DO IF YOU SMELL GAS

- Do not try to light any appliance,
- Do not touch any electrical switch; do not use any phone in your building,
- Immediately call your gas supplier from a neighbour's phone. Follow the gas supplier's instructions,
- If you cannot reach your gas supplier, call the fire department.

Qualified installer, service agency or the gas supplier must perform installation and service.

To the Installer: After installation, these instructions must be given to the end user or left on or near the appliance.

To the End User: This booklet contains important information about this appliance. Retain for future reference.



Contents

PART 1	GENERAL INFORMATION	1
1.1	INTRODUCTION.....	1
1.2	SPECIAL INSTRUCTIONS TO OWNER.....	1
1.3	CHECKING EQUIPMENT	1
1.4	DISPLAY UNIT	1
1.5	SEQUENCE OF OPERATION	1
1.5.1	Heat Transfer Process	1
1.5.2	End of Sequence.....	2
1.6	INSTALLATION CODES.....	2
1.7	WARRANTY	2
1.8	REMOVAL OF EXISTING APPLIANCE.....	3
1.9	BOILER/FURNACE ROOM OPERATING CONDITION	3
1.10	LOCATION OF UNIT	3
1.11	CLEARANCE FROM COMBUSTIBLE MATERIAL	4
PART 2	AIR INLET AND VENTING	8
2.1	GENERAL VENTING GUIDE	8
2.2	CATEGORY IV VENTING.....	8
2.2.1	Approved Venting Materials Category IV.....	8
2.3	CATEGORY II VENTING	9
2.3.1	Approved Venting Materials Category II.....	9
2.4	COMBINED COMBUSTION AIR INLET.....	10
2.5	VENT TERMINATION AND AIR INLET CLEARANCES.....	10
2.5.1	Sidewall Venting.....	10
2.5.2	Sidewall Air Inlet	11
2.5.3	Sidewall Concentric Vent/Air	11
2.6	Vertical Direct Venting.....	12
PART 3	GAS CONNECTION	13
3.1	GAS CONNECTION.....	13
3.2	GAS PIPING	13
3.3	INSTALL PIPING	13
3.4	CHECKING GAS SUPPLY PRESSURE	13
3.5	HIGH and LOW GAS PRESSURE SWITCHES (Optional)	14
3.6	AIR/GAS RATIO VALVE	14
3.7	BURNER.....	14
PART 4	WATER CONNECTION.....	15
4.1	FREEZE PROTECTION OUTDOOR INSTALLATION	15
4.2	WARNING REGARDING CHILLED WATER SYSTEMS	16
4.3	INLET AND OUTLET CONNECTIONS	16
4.4	MINIMUM PIPE SIZE REQUIREMENTS	16
4.5	HEAT EXCHANGER	16
4.6	LOW WATER TEMPERATURE SYSTEMS.....	16
4.7	PIPING ARRANGEMENTS	16
4.7.1	Field Supplied Components	16
4.8	FLOW PROVING DEVICE (wall mount models and combination models only).....	18
4.9	WATER FLOW SWITCH (Floor mount hydronic and DHW models only).....	18
4.10	LOW WATER CUTOFF (If Equipped)	18
4.11	RELIEF VALVE	18
4.12	DHW TUNING VALVE (combination models only)	18
PART 5	ELECTRICAL & CONTROLS.....	19
5.1	ELECTRICAL CONNECTIONS	19
5.2	HIGH LIMIT.....	19
5.3	DYNAMAX HS CONTROLLER.....	19
5.3.1	SERVICE PARTS	19
5.3.2	IGNITION MODULE LOCKOUT FUNCTIONS	20
5.4	ERROR TABLE	20

5.4.1	Manual Reset Codes.....	20
5.4.2	Automatic Reset Codes	20
PART 6	CONTROL PANEL	21
6.1	DYNAMAX HS CONTROLLER.....	21
6.2	SETTING THE DYNAMAX HS CONTROLLER.....	21
PART 7	COMPONENTS.....	37
7.1	DIRECT SPARK IGNITER	37
7.2	FLAME SENSOR	37
7.3	COMBUSTION AIR FAN	37
7.4	GAS VALVE	37
7.5	OUTER JACKET	37
PART 8	TROUBLESHOOTING.....	38
8.1	SETTING THE CORRECT COMBUSTION.....	47
8.2	GAS VALVE ADJUSTMENT PROCEDURE	47
PART 9	MAINTENANCE.....	49
9.1	EXAMINE THE VENTING SYSTEM	49
9.2	VISUALLY CHECK MAIN BURNER FLAMES.....	49
9.3	CLEANING BOILER HEAT EXCHANGER	49
9.4	CONDENSATE TREATMENT.....	50
9.5	IGNITER AND FLAME SENSOR ELECTRODES	50
9.6	CHECK IGNITER GROUND WIRING	50
9.7	BURNER MAINTENANCE	51
9.7.1	Burner Removal and Cleaning.....	51
9.8	REMOVAL OF COMBUSTION CHAMBER LINING	51
9.9	COMBUSTION AND VENTILATION AIR	51
9.10	GAS VALVE VOLTAGE	52
9.11	COMBUSTIBLE MATERIALS	52
9.12	FREEZE PROTECTION FOR INDOOR & OUTDOOR INSTALLATIONS	52
9.13	FREEZE PROTECTION FOR A HEATING BOILER SYSTEM (Optional).....	52
PART 10	INSTALLATIONS	53
10.1	CHECKING THE INSTALLATION.....	53
10.2	CHECKING THE CONSTRUCTION	53
10.3	HEATING BOILER INSTALLATIONS.....	53
10.4	INSPECT & RECHARGE CONDENSATE COLLECTION/NEUTRALIZING RESERVOIR	53
10.5	WATER CONNECTIONS	53
10.6	PIPING LENGTHS	53
10.7	SUMMARY.....	54
10.8	DOMESTIC HOT WATER WITH STORAGE TANK	54
10.9	DOMESTIC HOT WATER WITH PLATE HEAT EXCHANGER	54
10.10	TEMPERATURE RISE AT FULL FIRING RATE	55
10.11	LEAD LAG SETUP	56
10.12	LOCAL/REMOTE SWITCH	57
10.13	MODBUS/LOCAL SWITCH	57
10.14	APPLIANCE	57
PART 13	PIPING DIAGRAMS	58
PART 14	EXPLODED VIEW & PARTS LIST.....	63
PART 15	ELECTRICAL DIAGRAMS.....	72
15.1	DM 80- 299 INTERNAL WIRING DIAGRAM.....	72
15.2	DM 399 – 800 INTERNAL WIRING DIAGRAM.....	73
15.2	FIELD WIRING.....	75
15.2.1	System Sensor	75
15.2.2	Lead Lag Setup	75

PART 1 GENERAL INFORMATION

1.1 INTRODUCTION

The **DynaMax HS** boiler is a forced draft appliance utilizing a premix power burner based on a push through design which offers several venting options. Heat output is controlled by a one to one air/gas ratio control gas valve which provides seamless modulation. The boiler provides central heating, domestic hot water or combination heating with DHW priority at working pressure up to 160 PSI. It is designed for use with a fully pumped and pressurized water system. The boiler/water heater will automatically modulate to provide heat outputs from 100% down to approximately 20% of rated input.

The DynaMax HS utilizes a negative pressure gas valve. The operation of the fan will generate a negative pressure in the venturi, which draws in a matching amount of gas through the valve.

During operation the DynaMax HS maintains steady state efficiency across the entire range of modulation. Air and gas are metered in precise proportion (1:1 Ratio) allowing combustion characteristics which determine efficiency to remain the same over the entire operating range.

The DynaMax HS is designed so that all of the sensible heating value and most of the latent heat is being transferred to the water.

1.2 SPECIAL INSTRUCTIONS TO OWNER

This manual supplies information for the installation, operation and servicing of the appliance. It is strongly recommended that this manual be reviewed completely before proceeding with an installation

CAUTION

It is important that all gas appliances are installed by a qualified installer/technician. It is in your own interest and that of safety to ensure that all local codes, and all the following "NOTES" and "WARNINGS" are complied with. Installing, servicing or adjusting this appliance should be performed only by a qualified installer/technician that is trained by Camus® Hydronics. The serviceman must utilize a combustion analyzer with CO₂, CO, and draft gauge, to set the appliance according to Camus® Hydronics' recommendations, prior to commissioning.

NOTE

RETAIN THIS MANUAL FOR FUTURE REFERENCE

1.3 CHECKING EQUIPMENT

Check for signs of shipping damage upon receiving equipment. Pay particular attention to parts accompanying the boiler, which may show signs of being hit or otherwise being mishandled. Verify total number of pieces shown on packing slip with those actually received. In case there is damage or a shortage, immediately notify carrier.

1.4 DISPLAY UNIT

The display unit will indicate status and will display selected temperature. Refer to Part 6 Control Panel, which provides details to modes and error codes displayed on the appliance.

1.5 SEQUENCE OF OPERATION

- 1) Power switch is placed in the "ON" position.
- 2) Minimum 120 VAC 60Hz single phase (15A circuit) is supplied to the DynaMax HS field connection board.
- 3) 24Vac power is supplied to the DynaMax HS Controller which provides all setup and ignition control functions.
- 4) After the appliance water pump starts, flow is proven by the flow proving device or flow switch. The normally open dry contacts in the low water cutoff (LWCO), if supplied, is to be wired in series with the normally open contacts of the flow proving device.
- 5) Locate the probe type LWCO in the piping at least some distance above the boiler/ inlet connection. In all cases check with local codes.
- 6) Depending on the selected mode, the appliance operates as a master or slave configuration.
- 7) The DynaMax HS controller initiates a startup sequence once it receives a heat demand.
- 8) The DynaMax HS controller energizes the on-board pump and starts to ramp up the voltage to the electrically commutated DC motor of the combustion fan.
- 9) The fan will run at pre-purge speed until the pre-purge timer is satisfied. Once this is complete the DynaMax HS controller provides a signal to ignition fan speed.
- 10) The DynaMax HS controller goes through internal safety checks and if this is satisfied the ignition sequence begins.
- 11) The DynaMax HS controller supplies voltage to the air/gas ratio control valve. The air/gas ratio control valve senses the pressure across the venturi and supplies gas to pre-mix with air.
- 12) The igniter will spark for 4 seconds, with the gas valve opened, and the fan running at ignition speed.
- 13) Spark igniter lights the air/gas mixture. The DynaMax HS controller looks for a minimum flame rectification signal of 0.8Vdc from the flame sensor. If the signal is present, the DynaMax HS Controller will allow the gas valve to remain open. The burner is now firing at starting input rate.
- 14) Boiler will modulate to the correct fan speed to meet heat demand. The modulation rate is controlled via pulse width modulation (PWM) signal.
- 15) Fan speed will slowly decrease as heat request nears the heat demand. If heat demand is sustained for a long duration of time the boiler will get to a point of steady-state and the fan will rotate at constant speed.
- 16) When the heat demand is satisfied or is removed the burner will shut off and the fan speed will ramp up to the preset post-purge speed until the post-purge timer is satisfied.
- 17) The boiler will then go into standby as it waits for the next heat demand.

1.5.1 Heat Transfer Process

- 1) Burner input continues to increase until inlet water temperature reaches the setpoint temperature.
- 2) Burner input may stabilize at a fixed rate where demand equals input.
- 3) Burner input will decrease rate when outlet water temperature approaches temperature Setpoint.

1.5.2 End of Sequence

- 1) Setpoint temperature is satisfied.
- 2) Power to the gas valve is turned off.
- 3) Combustion air fan ramps to a stop over the factory preprogrammed time period.
- 4) Thermostat is now in standby mode waiting for the next "Call for Heat".

WARNING

To minimize the possibility of serious personal injury, fire or damage to your appliance, never violate the following safety rules.

DO NOT

Do not use this appliance if any part has been **under water**. The possible damage to a flooded appliance can be extensive and present numerous safety hazards. Immediately call a qualified service technician to inspect the boiler and to replace any part of the control system and any gas control which has been under water.

WHAT TO DO IF YOU SMELL GAS

Do not try to light any appliance. • Do not touch any electric switch: do not use any phone in your building.
• Immediately call your gas supplier from a neighbor's phone. Follow the gas supplier's instructions. • If you cannot reach your gas supplier, call the fire department.

IMPORTANT

Consult and follow local Building and Fire Regulations and other Safety Codes that apply to this installation. Contact the local gas utility company to inspect and authorize all gas and flue connections.

Installation and service must be performed by a qualified technician/installer, and trained by Camus® Hydronics.

WARNING

Should overheating occur or the gas supply fails to shut off, **DO NOT** turn off or disconnect the electrical supply to the pump. Shut off the gas supply at a location external to the appliance.

- Boilers and water heaters are heat producing appliances. To avoid damage or injury, do not store materials against the appliance or the vent-air inlet system. Use proper care to avoid unnecessary contact (especially children) with the appliance and vent-air inlet components.
- Never cover appliance, lean anything against it, store trash or debris near it, stand on it or in any way block the flow of fresh air to appliance.
- **UNDER NO CIRCUMSTANCES** may flammable materials such as gasoline or paint thinner be used or stored in the vicinity of this appliance, vent-air inlet system or any location from which fumes could reach the appliance or vent-air inlet system.
- A gas appliance that draws combustion air from the equipment room where it is installed must have a supply of fresh air circulating around it during burner operation for proper gas combustion and proper venting.

1.6 INSTALLATION CODES

The equipment shall be installed in accordance with those installation regulations enforced in the local area where the installation is to be made. These shall be carefully followed in all cases. Authorities having jurisdiction shall be consulted before installations are made. In the absence of such requirements, the installation shall conform to the latest edition or current as amended of the National Fuel Gas Code, ANSI Z223.1 and/or CAN/CGA-B149 Installation Code. All electrical wiring must be done in accordance with the requirements of the authority having jurisdiction or, in the absence of such requirements, with national electrical code, ANSI/NFPA70 and/or the Canadian electrical code part 1 CSA C22.1. Where required by the authority having jurisdiction, the installation must conform to American Society of Mechanical Engineers Safety Code for Controls and Safety Devices for Automatically Fired Boilers, ASME CSD-1. All boilers must conform to the latest edition of the ASME Boiler and Pressure Vessel Code, Section II. Where required by the authority having jurisdiction, the installation must comply with the CSA International, CAN/CGA-B149 and/or local codes. This appliance meets the safe lighting performance criteria with the gas manifold and control assembly provided, as specified in the ANSI standards for gas-fired units, ANSI Z21.13.

1.7 WARRANTY

- Factory warranty (shipped with unit) does not apply to units improperly installed or improperly operated.
- Factory warranty shall apply only when the appliance is installed in accordance with local plumbing and building codes, ordinances and regulations, the printed instructions provided with it and good industry practices.
- Excessive **water hardness** causing a lime build-up in the stainless steel coils or tubes is not a fault of the appliance and is not covered by warranty. Consult the factory for recommendations for use in hard water areas. (See Water Treatment and Water Chemistry)
- Using or storing **corrosive chemicals** in the vicinity of this appliance can rapidly attack the stainless steel venting and heat exchanger coils and voids warranty.
- Damage caused by **freezing or dry firing** voids warranty.
- This appliance is not to be used for **temporary heating** of buildings under construction.
- The manufacturer shall **NOT** be held liable for any personal injury or property damage due to ice formation or the dislodging of ice from the vent system or the vent termination

1.8 REMOVAL OF EXISTING APPLIANCE

When an existing appliance is removed from a common venting system, the common venting system is likely to be too large for proper venting of the appliances remaining connected to it. At the time of removal of an existing appliance, the following steps must be followed with each appliance remaining connected to the common venting system placed in operation, while the other appliances remaining connected to the common venting system are not in operation.

- Seal any unused openings in the common venting system.
- Visually inspect the venting system for proper size and horizontal pitch and determine that there is no blockage, restriction, leakage, corrosion or other deficiency, which could cause an unsafe condition.
- Insofar as is practical, close all building doors and windows and all doors between the spaces in which the appliances remaining connected to the common venting system are located and other spaces of the building. If applicable turn on the clothes dryers and any appliances not connected to the common venting system. Turn on any exhaust fans, such as range hoods and bathroom exhausts, so they will operate at maximum speed. Do not operate a summer exhaust fan. Close fireplace dampers.
- Place in operation the appliance being inspected. Follow the lighting instructions. Adjust thermostat so that appliance operates continuously.
- Test for spillage at the draft control device relief opening after 5 minutes of main burner operation. Use a cold mirror, the flame of a match, or a candle or smoke from a cigarette.
- After it has been determined that each appliance remaining connected to the common venting system properly vents when tested as outlined above, return doors, windows, exhaust fans, fireplace dampers and any other gas-burning appliance to their previous condition of use.
- Any improper operation of the common venting system should be corrected so that the installation conforms to the National Fuel Gas Code, ANSI Z223.1 and/or CAN/CGA B149, Installation Codes. When resizing any portion of the common venting system, the common venting system should be resized to approach the minimum size as determined using the appropriate tables in Part 11 of the National Fuel Gas Code, ANSI Z223.1 and/or CAN/CGA B149, Installation Codes.

Heat exchanger surfaces and vent piping should be checked every six months for deterioration and carbon deposits. Remove all soot or other obstructions from the chimney and flue, which might impede draft action. Replace any damaged or deteriorated parts of the venting system.

A qualified service technician should follow this procedure when inspecting and cleaning the heat exchanger and vent pipe.

- 1) Turn off electrical power and main manual gas shut-off and allow appliance to cool down.
- 2) Remove the vent pipe at connection to heat exchanger and check heat exchanger and vent for obstruction and clean as necessary.

- 3) Remove burner from appliance and carefully clean as required. Never brush or wipe the knitted metal fiber surface. Use a garden hose or gently wash under the tap. Vacuum out any deposits found in the heat exchanger.

CAUTION

Never use a pressure washer or compressed air to clean the burner.

- 4) Reinstall parts removed in steps 2 and 3. Be sure that vent pipe has proper pitch and is properly sealed. Replace any damaged gasket or refractory. Tighten fan flange mounting nuts to 3 ft-lb.
- 5) Restore electrical power and gas supply to appliance.
- 6) Place appliance in operation using lighting instructions provided.
- 7) Confirm proper operation of all safety devices
- 8) Check for gas leaks and proper vent operation.

NOTE

Experience has shown that improper installation or system design, rather than faulty equipment, is the cause of most operating problems

1.9 BOILER/FURNACE ROOM OPERATING CONDITION

- Due to low jacket losses from the appliance, temperatures in the vicinity of the boiler room may drop significantly; supplemental heat is required to maintain ambient temperature at acceptable levels.

1.10 LOCATION OF UNIT

Install this appliance in a clean, dry location with adequate service clearance.

- Do not locate this appliance in an area where it will be subject to freezing unless precautions are taken. Radiant losses from the heater is minimal and should not be relied on to keep the appliance room warm.
- Do not locate this appliance where it may be exposed to a corrosive atmosphere
- The appliance should be located close to a floor drain in an area where leakage from the appliance or connections will not result in damage to the adjacent area or to lower floors in the structure, it is recommended that a suitable drain pan, adequately drained, be installed under the unit. Under no circumstances is the manufacturer to be held responsible for water damage in connection with this unit, or any of its components.
- If the appliance is installed above the level of the building's radiation system, a low water cut-off device must be installed in the appliance outlet some distance above the heat exchanger inlet/outlet connections. Some local codes require the installation of a low water cut-off on all systems
- When placing the appliance be aware that a minimum clearance of 24" must be provided at the front to allow easy access to the heat exchanger. DynaMax HS wall mount units do not require access through the sides and can be placed adjacent to each other with zero clearance. Floor mount units require access on the left side as you face the front.

- The appliance must be installed so that the ignition system components are protected from water (dripping, spraying, etc.) during appliance operation and service (circulator replacement, control replacement, etc.)
- Appliances located in a residential garage and in adjacent spaces that open to the garage and are not part of the living space of a dwelling unit must be installed so that all burners and burner ignition devices have a minimum clearance of not less than 18" (46cm) above the floor. The appliance must be located or protected so that it is not subject to physical damage by a moving vehicle.
- **DO NOT** install this appliance in any location where gasoline or flammable vapors are likely to be present.
- Appliance must be installed on a level floor. Maintain required clearances from combustible surfaces.
- The appliance designed for indoor installation (Indoor Models) must be installed indoors where it is protected from exposure to wind, rain and weather.
- The appliance designed for outdoor installation (Outdoor Models) must be installed outdoors. Always consider the use of a shelter such as a garden shed in lieu of direct exposure of the appliance to the elements. The additional protection afforded by the shelter will help to minimize nuisance problems with electrical connections and will allow easier servicing of the appliance under severe weather conditions.

Figure 2: Floor Mount Clearance from Combustibles

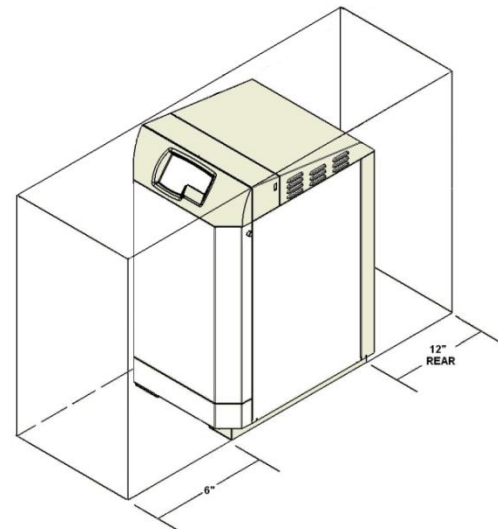

NOTE
Clearances from combustible construction are noted on the appliance rating plate

1.11 CLEARANCE FROM COMBUSTIBLE MATERIAL

This appliance is suitable for alcove (a closet without a door) installation with minimum clearances to combustibles as follows:

Table 1: Clearance from Combustibles

Clearances from Combustibles		
	Wall Hung Model	Floor Mount Model
TOP:	0"	0"
SIDES:	0"	0"
REAR:	0"	12"
VENT (Vent Adapter):	1"	1"
VENT (PVC/CPVC):	0"	0"
FRONT:	3"	6"

Figure 1: Wall Hung Clearance from Combustibles

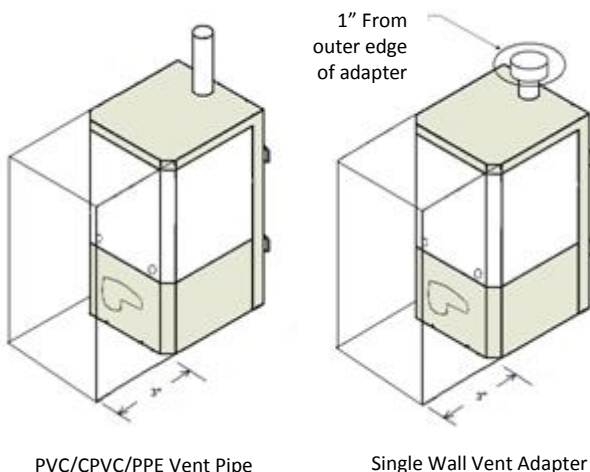

Table 2: DynaMax HS Wall Hung Service Clearances

Model	Service Clearance, Inches (cm)				
	Front	Top	Right Side	Left Side	Rear
80	24" (61cm)	3" (8 cm)	4" (10 cm)	4" (10 cm)	0" (0 cm)
100	24" (61cm)	3" (8 cm)	4" (10 cm)	4" (10 cm)	0" (0 cm)
150	24" (61cm)	3" (8 cm)	4" (10 cm)	4" (10 cm)	0" (0 cm)
200	24" (61cm)	3" (8 cm)	4" (10 cm)	4" (10 cm)	0" (0 cm)
250	24" (61cm)	3" (8 cm)	4" (10 cm)	4" (10 cm)	0" (0 cm)

Figure 3: DynaMax HS Wall Hung Model Dimensions

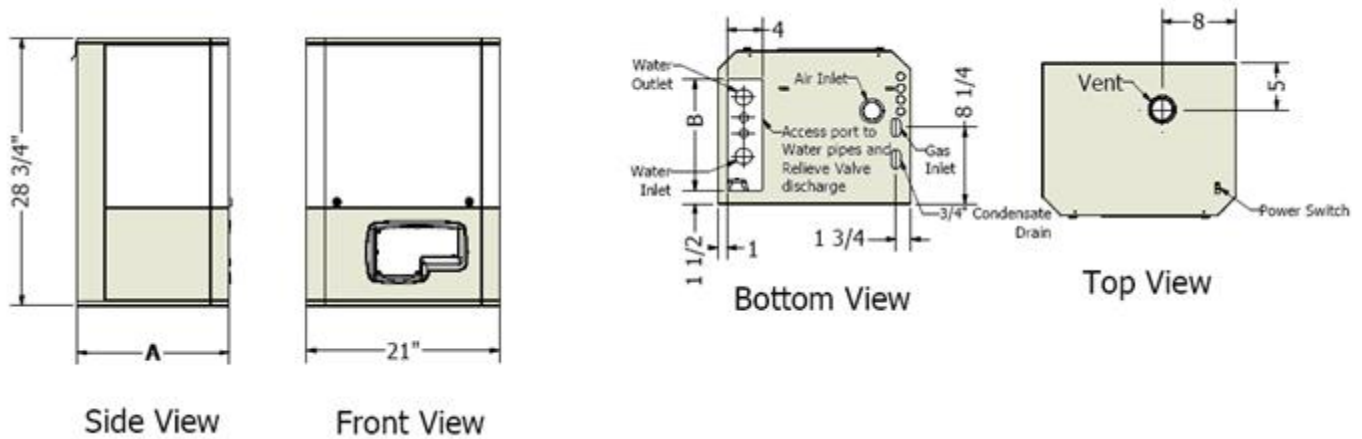

Table 3: Appliance Dimensions and Specifications

Model	Depth Dim. "A" [in.]	Dim. "B" [in.]	Equivalent Length of Vent & Air Intake Pipes at Recommended Diameter, [in.]			Water Connection at Boiler [in.] NPT	Gas Connection at Boiler [in.] NPT
			Over 25' and up to 100'	Over 15' and up to 25'	Up to 15'		
80	16 1/2	12	3	3	2	1	1/2
100	16 1/2	12	3	3	2	1	1/2
150	16 1/2	12	3	3	2	1	1/2
200	23 1/2	19	3	3	2	1	1/2
250	23 1/2	19	3	3	2	1 1/4	1/2

Maintain minimum specified clearances for adequate operation. All installations must allow sufficient space for servicing the vent connections, water pipe connections, circulating pump, bypass piping and other auxiliary equipment, as well as the appliance

Table 4: DynaMax HS Floor Mount Service Clearances

Model	Service Clearance, Inches (cm)				
	Front	Top	Right Side	Left Side	Rear
210	12" (31cm)	24" (61cm)	0" (0cm)	12" (31cm)	14" (36 cm)
260	12" (31cm)	24" (61cm)	0" (0cm)	12" (31cm)	14" (36 cm)
299	12" (31cm)	24" (61cm)	0" (0cm)	12" (31 cm)	14" (36cm)
399	12" (31cm)	24" (61cm)	0" (0cm)	12" (31 cm)	14" (36 cm)
500	12" (31cm)	24" (61cm)	0" (0cm)	12" (31 cm)	14" (36 cm)
600	12" (31cm)	24" (61cm)	0" (0cm)	12" (31 cm)	14" (36cm)
700	12" (31cm)	24" (61cm)	0" (0cm)	12" (31 cm)	14" (36 cm)
800	12" (31cm)	24" (61cm)	0" (0cm)	12" (31 cm)	14" (36 cm)

Figure 4: DynaMax HS Floor Mount Model Dimensions

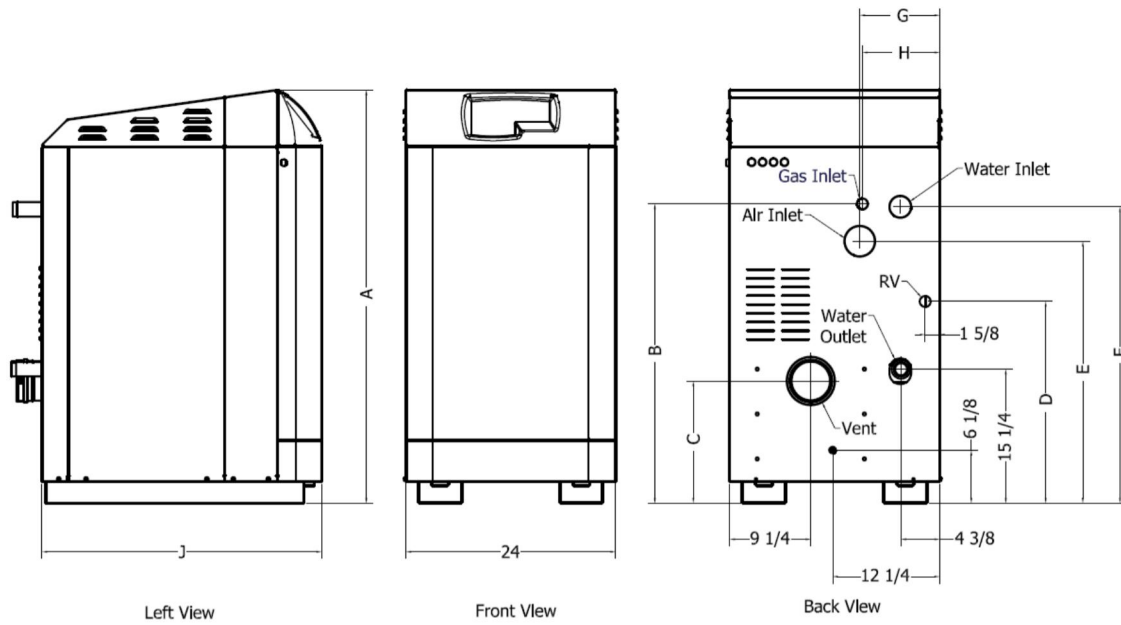

Table 5: Appliance Dimensions and Specifications

Model	Dim. "A" [in.]	Dim. "B" [in.]	Dim. "C" [in.]	Dim. "D" [in.]	Dim. "E" [in.]	Dim. "F" [in.]	Dim. "J" [in.]	Equivalent Length of Vent & Air Intake Pipes at Recommended Diameter, [in.]			Water Conn. at Heater [in.] NPT	Gas Conn. at Boiler [in.] NPT		
								Category IV						
								Over 25' and up to 100'	Over 15' and up to 25'	Up to 15'				
210	42 1/2	25 3/4	14 1/4	23	24 1/4	34 1/4	32	3	3	2	4	1	1/2	
260	42 1/2	25 3/4	14 1/4	23	24 1/4	34 1/4	32	3	3	2	4	1 1/4	1/2	
299	47 1/8	34 7/8	14	23	29 7/8	33 7/8	32	4	3	3	5	1 1/4	3/4	
399	47 1/8	34 7/8	14	23	29 7/8	33 7/8	32	4	3	3	5	1 1/2	1	
500	47 1/8	34 7/8	14	23	29 7/8	33 7/8	32	4	3	3	6	1 1/2	1	
600	47 1/8	36 1/4	14	23	30 3/4	38	40 1/2	4	3	3	6	2	1	
700	47 1/8	36 1/4	14	23	30 3/4	38	40 1/2	4 (Air), 6 (Vent)		4	4	7	2	1
800	47 1/8	36 1/4	14	23	30 3/4	38	40 1/2	5 (Air), 6 (Vent)		5	5	7	2	1

Maintain minimum specified clearances for adequate operation. All installations must allow sufficient space for servicing the vent connections, water pipe connections, circulating pump, bypass piping and other auxiliary equipment, as well as the appliance

Figure 5: DynaMax HS Wall Hung Service Clearances

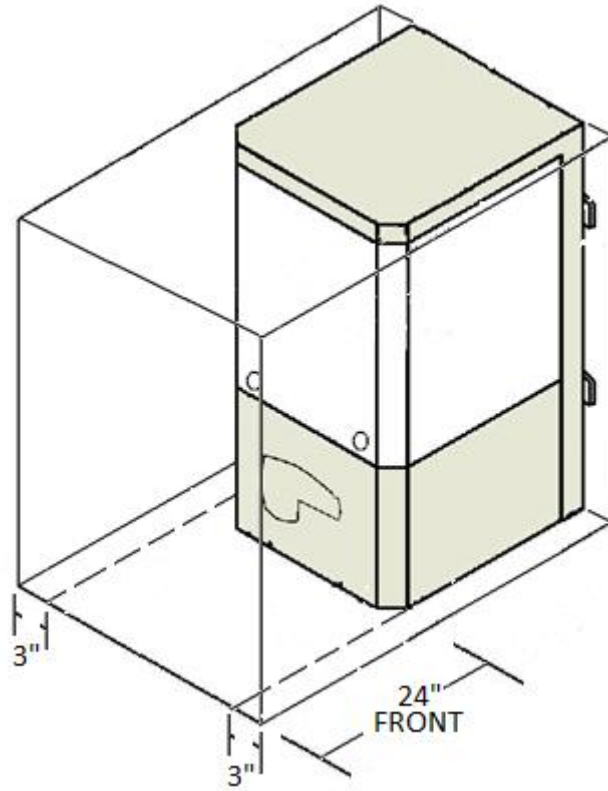
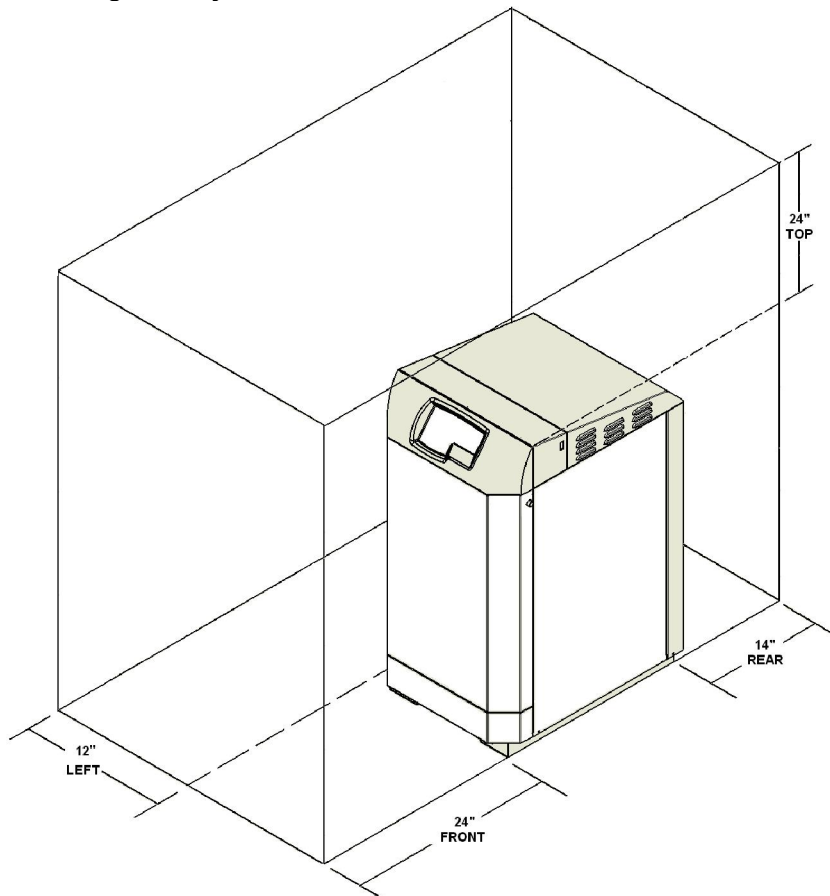

Figure 6: DynaMax HS Floor Mount Service Clearances



PART 2 AIR INLET AND VENTING

▲ DANGER

It is extremely important to follow these venting instructions carefully. Failure to do so can cause severe personal injury, death or substantial property damage.

2.1 GENERAL VENTING GUIDE

The DynaMax HS Wall Hung is a category IV condensing appliance, 97% efficient unit. The DynaMax HS Floor Mount is a category II condensing appliance, 97% efficient.

- The DynaMax HS may be vented with: manufactured prefabricated UL/ ULC listed vents of AL29-4C or 316L stainless steel or with plastic vent certified to UL/ ULC S636, such as, IPEX System 636 CPVC or IPEX System 636 PVC or as permitted by local jurisdictions.
- The DynaMax HS boiler must be vented and supplied with combustion and ventilation air as described in this section. Ensure that the venting and combustion air supply complies with these instructions.
- Provisions for combustion and ventilation air are to be in accordance with the section "Air for Combustion and Ventilation", Of the National Fuel Gas Code, ANSI Z223.1/NFPA 54, or clause 8.2, 8.3, or 8.4 of "Natural Gas and Propane Installation Code" CAN/CSA B149.1,2 or applicable provisions of the local building codes.
- The distance of the vent terminal from adjacent buildings, windows that open and building openings MUST comply with the latest edition of the National Fuel Gas Code, ANSI Z223.1 for U.S. installations or CAN/CGA Standard B149 Installation Code for Canadian Installations.
- Vent connection is made directly to the flue outlet opening on top of the unit for the wall mount unit and at the back of the unit for floor mount. The connection from the appliance vent to the stack must be made as direct as possible. The first 3 feet of vent from the appliance flue outlet must be readily accessible for visual inspection.
- Vent connectors serving appliances vented by natural draft shall not be connected into any portion of a mechanical draft system operating under positive pressure.
- A UL listed concentric vent/air intake kit may be used with the DynaMax HS.
- Horizontal runs of vent pipe shall be securely supported (approximately every 4 feet) to prevent sagging and maintain a minimum upward slope of 1/4" per foot from the appliance to the vent terminal.
- The weight of the venting system must not rest on the unit. Adequate support of the venting system must be provided in compliance with local codes and other applicable codes.
- All connections should be secured and sealed per the vent manufacturer's specifications. When a positive vent system is disconnected for any reason, the flue must be reassembled and resealed according to the vent manufacturer's instructions.
- Do not use an existing chimney as a raceway if another appliance or fireplace is vented through the chimney.

- Inspect completed vent and air supply piping thoroughly to ensure all connections are sealed and are in compliance with the instructions provided and satisfy requirements of all applicable codes.

NOTE

All vent pipes must be properly assembled and supported, and the exhaust must be pitched a minimum of 1/4 inch per foot back to the boiler. All components used to fabricate and assemble the vent system are to originate from the same supplier.

Equivalent length of fittings depends on centre line radius of the fitting. Consult published tables or the vent supplier for accurate equivalent lengths.

Example: 30 feet of CPVC pipe + (3 x 5 feet) 90° elbows + (1 x 3 feet) 45° elbow = 48 equivalent feet of piping for centerline radius of 1.5D, where D is the pipe diameter.

2.2 CATEGORY IV VENTING

A category IV appliance is individually vented through a dedicated vent.

The DynaMax HS Wall Hung boilers/ water heaters shall only be vented as a Category IV appliance.

For Category IV installations exceeding 100 equivalent feet an engineered vent system approved by the local authority will be required.

Both Wall Hung and Floor Mount appliances shall be vented using sealed positive vent suitable for a condensing appliance with the following venting options:

- 1) Sidewall or rooftop termination where both the vent and combustion air inlet air are in the same zone. The inlet and vent terminals are to be installed with a minimum 12" separation distance between centerline of inlet and centerline of exhaust. Refer to Fig. 8, 9, and 10 for sidewall termination and Fig. 11 for rooftop termination.
- 2) Sidewall termination with vent and combustion air inlet from separate zones.
- 3) Single Pipe thru wall or rooftop venting with combustion air inlet from the boiler room.

NOTE

Vent Option 3 not recommended for R-2000 homes or equivalent air tight construction.

2.2.1 Approved Venting Materials Category IV

- 1) PVC and CPVC (Chlorinated Polyvinyl Chloride) Schedule 40 approved to ULC S636.
- 2) Manufactured prefabricated UL/ULC listed vent of AL29-4C or 316L stainless steel. Use of 316L is limited to use in applications where there is no possibility of contaminants in the air such as refrigerants, chlorine etc.
- 3) PVC-DWV approved to comply with ANSI/ASTM D2665 (US Jurisdictions ONLY when permitted)
- 4) PVC Schedule 40 approved to comply with ANSI/ASTM D1785. (US Jurisdictions ONLY when permitted)
- 5) CPVC Schedule 40 approved to comply with ANSI/ASTM F441. (US Jurisdictions ONLY when permitted)
- 6) Polypropylene approved to comply with ULC S636

NOTE
1) Use of cellular core PVC (ASTM F891), cellular core PVC or Radel® (polyphenosulfone) in venting systems shall be prohibited.
2) Covering non-metallic vent pipe and fittings with thermal insulation shall be prohibited.

of the total rated input of the burner, provided that this does not conflict with local codes. This opening is in addition to the ventilation opening defined in paragraph a) above.

Table 6: Maximum Flue Temperature for Various Vent Materials

Vent Material	Maximum Flue Temperature [°F]
PVC	149
CPVC	194
PPE	230
AL29-4C	300+, limited only by rating of seals
316L Stainless Steel	300+, limited only by rating of seals

Stack temperature is typically between 15-30°F above inlet water temperature depending on model size and firing rate.

Air Inlet (Supply Air or Fresh Air) Piping

- PVC
- CPVC (Chlorinated Polyvinyl Chloride)
- PPE (Polypropylene)
- ABS (Acrylonitrile-Butadiene-Styrene)

Single wall air inlet pipes are to be insulated 5 feet from the wall toward the interior of the building to minimize external sweating.

The following air intake options shall be utilized:

- Outside air sealed direct (vertical or horizontal)
- Outside air ducted to jacket flange
- Indoor Air

NOTE
For wall hung units that are installed outdoors the bottom of the unit must be at least 36" above ground or 12" above normal snow levels.
NOTE
Sealed combustion is required when DynaMax HS is placed in a space with other fan-assisted appliances.

If air is taken directly from outside the building with no duct, provide two permanent openings:

- Ventilation of the space occupied by fuel burning appliance(s) or equipment shall be supplied by a ventilation opening at the highest practicable point communicating with the outdoors. The total cross sectional area of the ventilation opening must be either 10% of the net free area required for combustion air or 10 sq. in. (6500 mm²) whichever is greater.
- Net free area for combustion air opening shall be in accordance with all applicable codes. In the absence of such codes provide combustion air opening with a minimum free area of one square inch per 7000 Btuh input (5.5 cm per kW) up to 1,000,000 Btuh and one square inch per 14,000 Btuh in excess of 1,000,000 Btuh. This opening must be ducted no higher than 18" nor less than 6" above the floor.
- In extremely cold climates when air supply is provided by natural air flow from outdoors we recommend sizing the combustion air-supply opening with a minimum free area of not less than one square inch per 30,000 Btu/hr,

NOTE
Outside air openings shall directly communicate with the outdoors.
CAUTION
Under no circumstances should the mechanical room ever be under a negative pressure. Particular care should be taken where exhaust fan, attic fans, clothes dryers, compressors, air handling units, etc., may take away air from the unit.

Table 7: Required Vent and Air Inlet Diameters

Model	Equivalent Length of Vent & Air Intake Pipes at Recommended Diameter*			
	Category IV			Category II
	Over 25' and up to 100'	Over 15' and up to 25'	Up to 15'	
80	3"	3"	2"	-
100	3"	3"	2"	-
150	3"	3"	2"	-
200	3"	3"	2"	-
210	3"	3"	2"	4"
250	3"	3"	2"	-
260	3"	3"	2"	4"
299	4"	3"	3"	5"
399	4"	3"	3"	5"
500	4"	3"	3"	6"
600	4"	3"	3"	6"
700	4" (Air), 6" (Vent)	4"	4"	7"
800	5" (Air), 6" (Vent)	5"	5"	7"

* Consult factory for recommendations applicable to venting combinations not shown above.

2.3 CATEGORY II VENTING

A category II appliance may be combined into a common negative pressure venting system designed to ASHRAE requirements using a proven vent sizing program. Vent designs are to be certified by a qualified professional designer acceptable to the authority having jurisdiction.

The DynaMax HS Floor Mount boiler may be vented as a Category II appliance using sealed vent suitable for a condensing appliance.

2.3.1 Approved Venting Materials Category II

- PVC and CPVC Schedule 40 approved to ULC S636.
- Manufactured prefabricated UL/ULC listed vent of AL29-4C or 316L stainless steel. Use of 316L is limited to use where there is no possibility of contaminants in the air such as refrigerants, chlorine etc.
- PVC-DWV approved to comply with ANSI/ASTM D2665 (US Jurisdictions ONLY when permitted).
- PVC Schedule 40 approved to comply with ANSI/ASTM D1785. (US Jurisdictions ONLY when permitted)
- CPVC Schedule 40 approved to comply with ANSI/ASTM F441. (US Jurisdictions ONLY when permitted).

6) Polypropylene approved to comply with ULC S636

Air Inlet (Supply Air or Fresh Air) Piping

- PVC
- CPVC (Chlorinated Polyvinyl Chloride)
- ABS (Acrylonitrile-Butadiene-Styrene)
- PPE (Polypropylene)

Single wall air inlet pipes are to be insulated 5 feet from the wall toward the interior of the building to minimize external sweating.

The following air intake options shall be utilized:

- Outside air sealed direct (vertical or horizontal)
- Outside air ducted to jacket flange
- Indoor Air

NOTE

Sealed combustion is required when DynaMax HS is placed in a space with other fan-assisted appliances.

2.4 COMBINED COMBUSTION AIR INLET

To avoid the possibility of nuisance lockouts in cold climates install DynaMax HS appliances may be installed with a combined combustion air inlet.

The combined combustion air inlet pipe sizing can be calculated using the method shown below:

Equivalent pipe diameter = Sq Root $[(d_1)^2 + (d_2)^2 + (d_3)^2 + \dots + (d_n)^2]$, where d_n = individual pipe diameter

- Example: Find the equivalent pipe diameter of three air inlet pipes, 3" (7.6cm), 3" (7.6cm) and 4" (10.2cm)

Equivalent pipe diameter = Sq Root $[(3)^2 + (3)^2 + (4)^2]$ = Sq Root(34) = 5.8", select 6" (15.3cm) equivalent diameter pipe.

Air inlet point for multiple boiler air inlets must be provided with an exterior opening which has a free area equal to or greater than the total area of all air inlet pipes connected to the common air inlet. This exterior opening for combustion air must connect directly to the outdoors. The total length of the combined air inlet pipe must not exceed a maximum of 100 equivalent feet (30.5m). Compensate for the restriction in an area provided by any screens, grills or louvers installed in the common air inlet point. Screens, grills or louvers installed in the common air inlet can reduce the free area of the opening from 25 to 75% based on the materials used. Increase the inlet accordingly.

2.5 VENT TERMINATION AND AIR INLET CLEARANCES

2.5.1 Sidewall Venting

- The first 3 feet (1m) of vent from the appliance flue outlet must be readily accessible for inspection.

Figure 7: Vertical Orientation

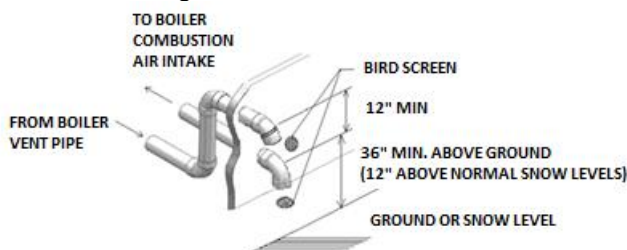
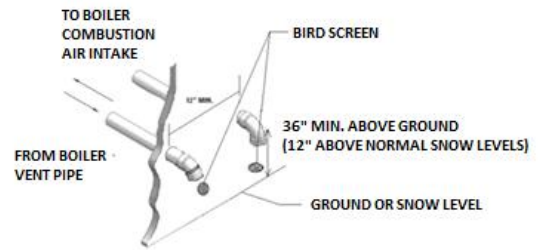

Figure 8: Horizontal Configuration



*Always check local codes for minimum distance above ground or snow levels.

Location of Vent Termination

- 1) Total length of vent piping must not exceed limits stated in Table 7.
- 2) Bottom of vent terminal shall be located at least 3 feet (0.90m) above grade or above normal snow levels. In all cases the appliance shall be installed in accordance with local codes
- 3) DynaMax HS can vent up to 100 equivalent feet. Elbows can range from 3 to 5 feet in equivalent length depending on the centerline radius.
- 4) Vent outlet shall terminate at least 12" (0.30m) away from any forced air inlet. Vent must be at least 7 feet (2.15m) above grade when located adjacent to public walkways due to normal formation of water vapour in the combustion process.
- 5) Vent outlet **MUST NOT** terminate below a forced air inlet at any distance.
- 6) Vent cannot terminate below grade. Position vent termination where vapours will not damage walls or plants or may be otherwise objectionable.
- 7) Vent terminal shall not be installed closer than 3 feet (1m) from an inside corner of an L-shaped structure, window well, stairwell, alcove, courtyard or other recessed area as wind eddies could affect boiler performance or cause recirculation.
- 8) **DO NOT** terminate closer than 4 feet (1.25m) horizontally and vertically from any electric meter, gas meter, regulator, relief valve, or other equipment. In all cases local codes take precedence
- 9) Position terminations so they are not likely to be damaged by foreign objects, or exposed to a build-up of debris.
- 10) Vent piping must terminate in an elbow pointed outward or away from air inlet.
- 11) Flue gas condensate can freeze on exterior walls or on the vent cap. Frozen condensate on the vent cap can result in a blocked flue condition. Keep the vent cap/terminal clear of snow, ice, leaves, debris etc. Some discoloration to exterior building surfaces is to be expected. Adjacent brick or masonry surfaces should be protected with a rust resistant sheet metal plate.
- 12) Perform regularly scheduled inspections to ensure vent terminal is unobstructed.

2.5.2 Sidewall Air Inlet

Figure 9: Sidewall Vent and Air Inlet Configuration

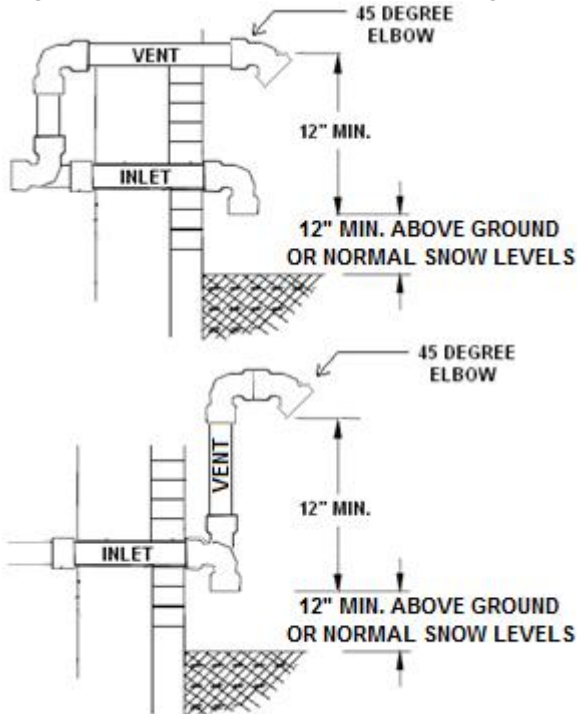

* Always check local codes for minimum distance above ground or snow levels

Location of a Sidewall Air Inlet Cap

- 1) Total length of piping for air inlet must not exceed the limits stated in Table 7.
- 2) Point of termination for the sidewall air inlet cap must be located a minimum of 12 inches (0.30m) away from the flue gas termination, but never above.
- 3) Air piping must terminate in a down-turned elbow to avoid recirculation of flue products into the inlet air stream.
- 4) **DO NOT** terminate closer than 4 feet (1.25m) horizontally and vertically from any electric meter, gas meter, regulator, relief valve, or other equipment. In all cases local codes take precedence
- 5) **DO NOT** terminate the air inlet in a window well, stairwell, alcove, courtyard or other recessed area as wind eddies could affect performance or cause recirculation.
- 6) Air inlet cannot terminate below grade.
- 7) Locate terminations so they are not likely to be damaged by foreign objects, or exposed to build-up of debris.
- 8) Perform regularly scheduled inspections to ensure that the air inlet terminal is unobstructed.

2.5.3 Sidewall Concentric Vent/Air

A concentric vent kit can be used with the DynaMax HS appliance. Both combustion air and vent pipes must terminate outside the structure.

- 1) Total length for venting or air must not exceed the limits stated in Table 7.

- 2) Bottom of the termination shall be located at least 3 feet (0.90m) above grade or above normal snow levels. In all cases the appliance shall be installed in accordance with local codes
- 3) Termination **MUST NOT** terminate below a forced air inlet at any distance
- 4) Termination cannot terminate below grade. Position the termination where vapours will not damage walls or plants or may be otherwise objectionable.
- 5) The termination shall not be installed closer than 3 feet (1m) from an inside corner of an L-shaped structure, window well, stairwell, alcove, courtyard or other recessed area as wind eddies could affect boiler performance or cause recirculation.
- 6) **DO NOT** terminate closer than 4 feet (1.25m) horizontally and vertically from any electric meter, gas meter, regulator, relief valve, or other equipment. In all cases local codes take precedence
- 7) Position termination so they are not likely to be damaged by foreign objects, or exposed to a build-up of debris.
- 8) Flue gas condensate can freeze on exterior walls or on the vent cap. Frozen condensate on the vent cap can result in a blocked flue condition. Keep the vent cap/terminal clear of snow, ice, leaves, debris etc. Some discoloration to exterior building surfaces is to be expected. Adjacent brick or masonry surfaces should be protected with a rust resistant sheet metal plate.
- 9) Perform regularly scheduled inspections to ensure that the termination is unobstructed.
- 10) Operate the appliance for one heat cycle to ensure combustion air and vent pipes are properly connected to the concentric vent termination connections.

CAUTION
Do not operate appliance with the terminal cap removed as this may result in the recirculation of flue products.

Figure 10: Concentric Sidewall Termination

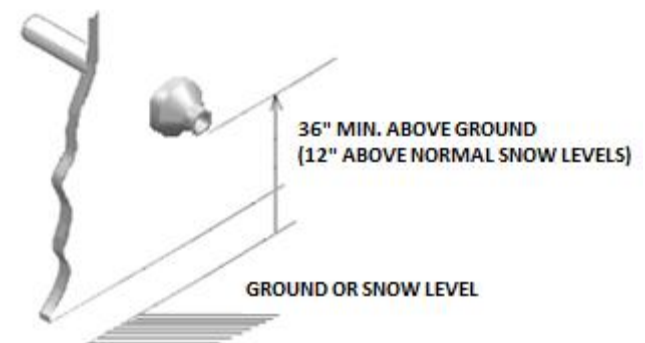
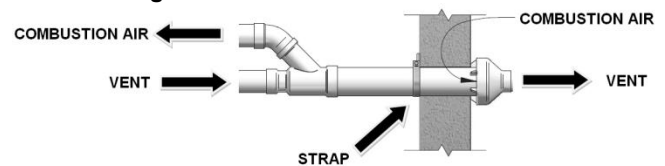

Figure 11: Concentric Vent Sidewall



Termination and Fittings

The air inlet opening must be at least 12 inches (0.30m) away from (never above) the vent termination and at least 3 feet (1m) above grade or 1 foot (0.30m) above normal maximum snow levels.

2.6 Vertical Direct Venting

Location of Vent Termination

- 1) Total length of piping for venting must not exceed limits stated in Table 7.
- 2) Vent piping must terminate in a 45° elbow if plastic piping is used or in an approved vent cap if using metal venting. Vent outlet must be at least 1 foot away and 1 foot above from the air inlet opening which must terminate in a double elbow facing downwards.
- 3) Vertical termination must be a minimum of 3 feet (1m) above the point of exit or 1 foot (0.30m) above normal snow levels.
- 4) Vertical termination less than 10 feet (3.05m) from a parapet wall must be a minimum of 2 feet (0.61m) higher than the parapet wall.
- 5) **DO NOT** terminate closer than 4 feet (1.25m) horizontally and vertically from any electric meter, gas meter, regulator, relief valve, or other equipment. In all cases local codes take precedence.
- 6) Position the air inlet and vent terminations so they are not likely to be damaged by foreign objects, or exposed to build-up of debris.
- 7) Perform regularly scheduled inspections to ensure that the vent terminal is unobstructed.
- 8) Termination **MUST NOT** terminate below a forced air inlet at any distance

Location of a Vertical Air Inlet Opening

- 1) The total length of piping for inlet air must not exceed the limits given in Table 7.
- 2) The air inlet consists of two 90° elbows installed at the point of termination for the vertical air inlet pipe. A 90° elbow and a 90° street elbow may be used to make this assembly. If a straight piece of pipe is used between the two elbows, it should not exceed 6" (0.15m) in length. The air inlet opening must be at least 1 foot below the vent opening. The air piping must be no further than 2 feet (0.6m) from the center of the vent pipe. This arrangement avoids exhaust gases from re-circulating into the inlet air stream. Refer to Figure 12.
- 3) Air inlet must terminate at least 3 feet (1.0m) above the roof or 1 foot (0.3m) above normal snow levels and at least 1 foot (0.3m) below the vent termination.
- 4) Locate terminations so they are not likely to be damaged by foreign objects or exposed to build-up of debris.
- 5) Perform regularly scheduled inspections to ensure that the air inlet terminal is unobstructed.

Figure 12: Vertical Direct Venting Configuration

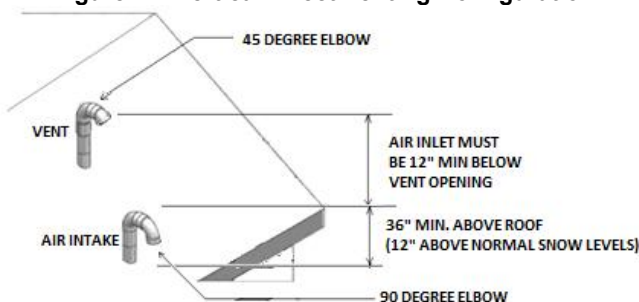

- 6) Operate the appliance for one heat cycle to ensure combustion air and vent pipes are properly connected to the concentric vent termination connections.

Figure 13: Concentric Vent Vertical Venting

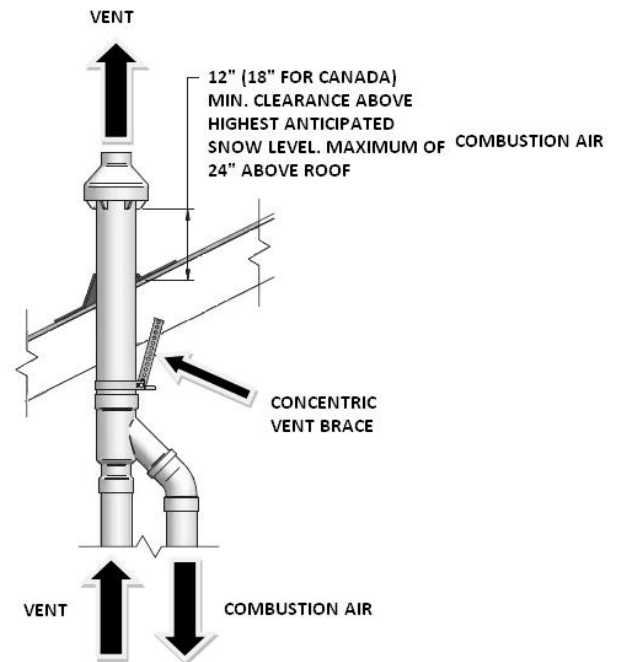

CAUTION
Do not operate appliance with the terminal cap removed as this may result in the recirculation of flue products. Water may also flow into the combustion air pipe and into the burner enclosure.

Length of Air Inlet Pipe

The maximum total length of the vertical roof top combustion air inlet pipe as installed from the appliance to the terminal cap must not exceed 100 equivalent feet (30.5m) in length.

IN GENERAL

- The operation of exhaust fans, compressors, air handling units etc. can rob air from the room, creating a negative pressure condition leading to reversal of the natural draft action of the venting system. Under these circumstances an engineered air supply is necessary.
- If the appliance is to be installed near a corrosive or potentially corrosive air supply, the appliance must be isolated from it and outside air supplied as per code.
- Potentially corrosive atmospheres will result from exposure to permanent wave solution, chlorinated waxes and cleaners, chlorine, water softening chemicals, carbon tetrachloride, halogen based refrigerants, Freon cleaning solvents, hydrochloric acid, cements and glues, masonry washing materials, antistatic fabric softeners, dry cleaning solvents, degreasing liquids, printing inks, paint removers, etc.
- The equipment room **MUST** be provided with properly sized openings to assure adequate combustion air and proper ventilation when the unit is installed with a proper venting system.

PART 3 GAS CONNECTION

Verify that the appliance is supplied with the type of gas specified on the rating plate. Consult factory for installations at high altitude.

3.1 GAS CONNECTION

- Safe operation of unit requires properly sized gas supply piping. See gas line sizing data.
- Gas pipe size may be larger than appliance connection.
- Installation of a union at the appliance gas line connection is required for ease of service and removal of the gas train.
- Install a manual main gas shutoff valve, outside of the appliance as required by local codes.
- A trap (drip leg) MUST be provided in the inlet gas connection to the appliance.
- Optional gas controls may require routing of bleeds and vents to the atmosphere, outside the building when required by local codes.

Table 8: Recommended Gas Pipe Size

Single Appliance Installation

(For distance from natural gas meter or propane second stage regulator)

Input Btu/Hr, x1000	0-100 FT		101-200 FT		201-300 FT	
	NAT.	L.P.	NAT.	L.P.	NAT.	L.P.
80	3/4"	1/2"	3/4"	1/2"	1"	3/4"
100	3/4"	1/2"	1"	3/4"	1"	3/4"
150	1"	3/4"	1 1/4"	1"	1 1/4"	1"
200	1"	3/4"	1 1/4"	1"	1 1/4"	1"
250	1 1/4"	1"	1 1/4"	1"	1 1/2"	1 1/4"
299	1 1/4"	1"	1 1/2"	1 1/4"	1 1/2"	1 1/4"
399	1 1/4"	1"	1 1/2"	1 1/4"	2"	1 1/2"
500	1 1/2"	1 1/4"	2"	1 1/2"	2"	1 1/2"
600	1 1/2"	1 1/4"	2"	1 1/2"	2"	1 1/2"
700	2"	1 1/2"	3"	2 1/2"	3"	2 1/2"
800	2"	1 1/2"	3"	2 1/2"	3"	2 1/2"

3.2 GAS PIPING

All gas connections must be made with pipe joint compound resistant to the action of liquefied petroleum and natural gas. All piping must comply with local codes and ordinances.

3.3 INSTALL PIPING

- The gas line must be sufficient to handle the total installed capacity. Verify pipe size with your gas supplier.
- Use approved piping as per code.
- Install a manual main gas shutoff valve at the appliance gas inlet, outside of the appliance and before the gas valve.
- Run pipe to the Appliance gas inlet.
- Install a sediment trap in the supply line to the Appliance gas inlet.
- Apply a moderate amount of good quality pipe compound.
- For LP gas, consult your LP gas supplier for expert installation.

The appliance and its individual gas shut-off valve must be disconnected from the supply piping when pressure testing the gas supply piping at pressures above 1/2 PSI

Table 9: Gas Pressures at Inlet to Appliance

	PROPANE	NATURAL GAS
Minimum (inches W.C.)	11	3*
Maximum (inches W.C.)	11	14

* 7" w.c. recommended regulator setting

The gas supply line must be of adequate size to prevent undue pressure drop and must never be smaller than the size of the connection on the appliance. Sizing based on Table 8 is recommended, depending on model.

Before operating the appliance, the complete gas train and all connections must be tested using soap solution.

Verify that the appliance is supplied with the type of gas specified on the rating plate. Heating values of local natural gas are to be between 950 and 1010 Btu/ft³. Consult factory if heating values are outside this range or if a gas with a mixture of constituents is being used.

3.4 CHECKING GAS SUPPLY PRESSURE

- Turn main power switch to "OFF" position.
- Shut off gas supply at the manual gas cock in the gas piping to the appliance. If fuel supply is LP gas, shut off gas supply at the tank.
- **DM80 – 399:** Loosen the slotted screw from the gas pressure test port on the gas valve. Connect manometer or magnahelic gauge to test port. Range of scale should be 0 to 14 inch W.C. or greater to check inlet pressure.
- **DM500 – 800:** Remove the 1/8" hex plug from the gas pressure test port located upstream of gas valve. Install a pressure tapping suitable to connect to a manometer or magnahelic gauge. Range of scale should be 0 to 14 inch W.C. or greater to check inlet pressure.
- Turn on gas supply at field installed manual gas cock; turn on LP gas at tank if required.
- Turn power switch to "ON" position.
- Initialize call for heat.
- Observe the gas supply pressure as the burner fires at 100% of rated input. Supply pressure is to remain stable.
- Ensure inlet pressure is within specified range as specified in Table 9.
- If gas pressure is out of range, contact the gas utility, gas supplier, qualified installer or service agency to determine necessary steps to provide proper gas pressure to the control.
- If gas supply pressure is within normal range, proceed to remove gas manometer and tighten slotted screw on gas valve (DM80 – 399) or replace pressure tap fittings in the gas piping to the appliance (DM500 – 800). Turn power switch to "OFF" position.
- Turn on gas supply at the manual valve; turn on LP gas at tank if required.
- Turn power switch to "ON" position.
- Adjust set point to the desired water temperature.
- Check appliance performance by cycling the system while you observe burner response. The burner should ignite promptly. Flame profile should be stable, see section 11.2, Visually Check Main Burner Flames. Turn system off and allow burner to cool, then cycle burner again to ensure proper ignition and flame

characteristics.

IMPORTANT

Upon completion of initial installation or following any repair work on the gas system, leak test all gas connections with a soap solution while the main burner is firing. Immediately repair any leak found in the gas train or related components. **DO NOT** operate an appliance with a leak in the gas train, valves or related gas piping.

3.5 HIGH and LOW GAS PRESSURE SWITCHES (Optional)

Figure 14: Low gas pressure switch (cover removed)



High and low gas pressure switches are available as an option and are wired in series with the normally closed blocked flue switch. The high gas pressure switch is used to monitor the gas pressure at the outlet of the control valve. If gas pressure exceeds the maximum setting of the pressure switch, the appliance will shut down and an ILK OFF message will be indicated on the display. The low gas pressure switch is to monitor the minimum incoming gas supply pressure supplied to the gas train. If gas pressure falls below the minimum setting of the pressure switch, the appliance will shut down and an ILK OFF message will be displayed.

3.6 AIR/GAS RATIO VALVE

The main gas valve supplying gas to the burner on this appliance utilizes a servo pressure regulator providing a slow opening, fast closing safety shut off and air/gas ratio control for the gas combustion process. The valve is a 1:1 negative pressure gas valve. The valve performs the functions of a pressure regulator, safety shutoff, and air/gas ratio control. Full closing of the valve seat occurs in less than 0.8 seconds when the valve is de-energized. Operation of the gas valve in combination with the combustion air fan allows the burner input rate to vary from 20% to 100% based on temperature demand. The inlet gas supply pressure must be maintained within the specified minimum and maximum pressures as indicated in Table 9.

The air/gas ratio is preset at the factory and adjustment is not usually required if gas supply pressure is maintained within the specified range. There are no serviceable parts on the air/gas ratio valve control.

Figure 15: DynaMax HS 80 – 250, 260 1:1 Air/Gas Ratio Control Valve



Gas Inlet

High fire adjustment: use throttle screw located on venturi
Low fire adjustment screw Torx 40 clockwise increases CO₂

Figure 16: DynaMax HS 299 – 399 1:1 Air/Gas Ratio Control Valve

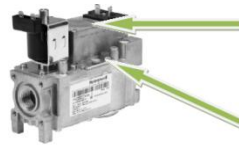

Low-fire air gas ratio adjustment (use Torx 40 for adjustment clockwise increases CO₂)
High-fire air gas ratio adjustment (Use slotted screwdriver for adjustment, counter-clockwise increases CO₂)

Figure 17: DynaMax HS 500 – 800 1:1 Air/Gas Ratio Control Valve

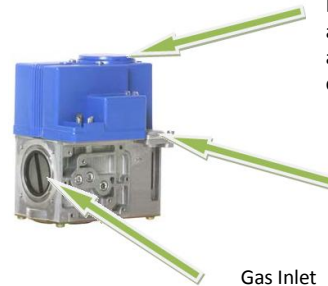

Lift top cover to access high fire air/gas ratio adjustment (use 3mm allen key for adjustment, counter-clockwise increases CO₂)

Low-fire air/gas ratio adjustment, use slotted screwdriver for adjustment, clockwise increases CO₂

Gas Inlet

3.7 BURNER

Figure 18: DynaMax HS Burner



This appliance uses a single cylindrical burner installed horizontally into the cavity located in the center of the heat exchanger. A unique burner is used for each one of the DynaMax HS models.

Burners may NOT be interchanged between different Btu/hr input models. The burner consists of a round mounting flange welded to a ported stainless steel mixing tube. This stainless steel tube is covered with a close fitting, knitted stainless steel metal fiber alloy material that forms the burner outer surface. The burner is setup to operate in blue mode and infrared operating condition should be avoided. Infrared operation will occur only if air to gas adjustments is incorrect. If infrared operation is noted the cause must be corrected.

The burner should be removed for inspection and cleaning on an annual basis. An appliance installed in a dust or dirt contaminated environment will require inspection and cleaning on a more frequent schedule. The fan assisted combustion process may force airborne dust and dirt contaminants, contained in the combustion air, into the burner. With sustained operation, non-combustible contaminants may reduce burner surface area, reduce burner input or cause non-warrantable damage to the burner.

Airborne contaminants such as dust, dirt, concrete dust or dry wall dust can be drawn into the burner with the combustion air and block the burner surface area. **DO NOT** operate this appliance during construction.

The spark igniter and flame sensor are removable from the combustion chamber mounting door without removing the burner assembly.

Never use an open flame (match, lighter, etc.) to check gas connections.

Regulated Gas Supply Pressures for DynaMax HS Boilers & Water Heaters

A stable gas supply pressure is important to avoid rough starts with machines like the DynaMax HS which use a 1 to 1 ratio control valve for internal gas pressure regulation. Camus® requires that all DynaMax HS models be supplied with no more than 14" w.c. supply pressure. This means that lockup pressure must not exceed 14" w.c.

A suitable lockup regulator with internal or external relief will not exceed running pressure by more than 20%.

When required a final stage gas regulator is to be located as close as possible but no more than 10 feet from the appliance.

It is paramount that maximum lockup pressure be confirmed before any attempt is made to start up the appliance.

Operating the DynaMax HS at lockup pressures exceeding 14" w.c. could lead to delayed ignitions and damage to the appliance.

PART 4 WATER CONNECTION

- Check all applicable local heating, plumbing and building safety codes before proceeding.
- If the appliance is installed above radiation level it must be provided with a low water cut-off device at the time of appliance installation (available from Camus®). Some local codes require the installation of a low water cut-off on all systems.
- Before connecting DynaMax HS to piping in a closed loop system, flush system thoroughly and refill with clean water and add chemical treatment to bring into balance.
- Follow the chemical suppliers instructions. A regular maintenance schedule will ensure that acceptable water quality is maintained, typically a Langlier/ Reznor index will provide this information.
- Strainers are recommended to be installed into the system to prevent foreign objects from entering the heat exchanger.
- A pressure relief valve is supplied with each DynaMax HS. The relief valve must be mounted in a vertical position and piped to the floor in a manner acceptable to the enforcing authority.
- Be sure to provide unions and gate valves at inlet and outlet to the appliance so that it can be easily isolated for service.
- On combination heaters a flow setter valve at the appliance outlet facilitates setting of the desired outlet temperature at high fire. Refer to Section 10.9 Domestic Hot Water with Plate Heat Exchanger for more details
- This appliance is a low mass stainless steel tube design which provides for instant heat transfer. All appliances are supplied with an internal suitable specific pump mounted in place. When replacing the pump, replace with one of equal or better-performance.
- An air vent is supplied on the heat exchanger header to eliminate trapped air. Install venting devices at high points in the system as well to eliminate trapped air in the piping.
- Use suitable pipe hangers or floor stands to support the weight of all water and gas piping.
- The DynaMax HS must be installed so that the gas ignition system components are protected from water (dripping, spraying, rain, etc.) during appliance operation and service (circulator replacement, control replacement, etc.)

4.1 FREEZE PROTECTION OUTDOOR INSTALLATION

- Appliance installations are not recommended outdoors or in areas where danger of freezing exists unless precautions are taken. Maintaining a mixture of 70% water and 30% propylene glycol is the preferred method of freeze protection in hydronic systems. **DO NOT** exceed a mixture of 50/50. This mixture will protect the appliance to approximately -35°F (-37°C). Follow the chemical suppliers directions.
- For outdoor installations a snow screen should be installed to prevent snow and ice accumulation around the appliance. Regular inspections should be made to ensure that air inlet and vent are free of snow and ice. Always consider the use of a shelter such as a garden shed in lieu of direct exposure of the appliance to the elements. The additional protection afforded by the

shelter will help to minimize nuisance problems with electrical connections and will allow easier servicing of the appliance under severe weather conditions.

4.2 WARNING REGARDING CHILLED WATER SYSTEMS

When an appliance is connected to an air conditioning system where the same water is used for heating and cooling, the chiller must be piped in parallel with the appliance. Appropriate isolation valves; manual or motorized must be provided to prevent the chilled water from entering the appliance.

Figure 19: Chilled Water System

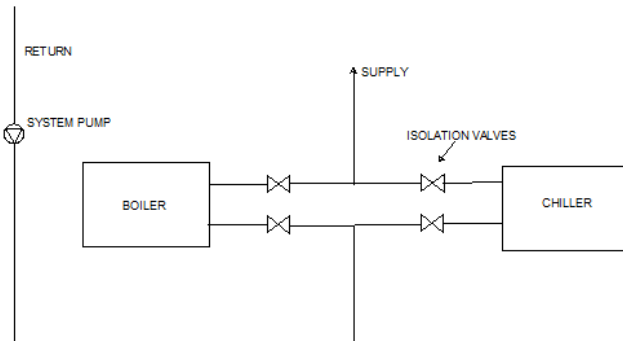

4.3 INLET AND OUTLET CONNECTIONS

- All water connections must meet American National Standard Pipe Threads (NPT).
- For ease of service, install unions on inlet and outlet of the appliance. The connection to the appliance marked "Inlet" on the header should be used for return from the system. The connection on the header marked "Outlet" is to be connected to the supply side of the system.

4.4 MINIMUM PIPE SIZE REQUIREMENTS

Minimum water pipe connections are as follows for DynaMax HS single unit installations. The equivalent number of straight feet of pipe for each valve and fitting in the connecting piping must be considered to properly arrive at the total equivalent feet of straight pipe in the field installed piping to the appliance. Consult factory if longer piping distances are required for a specific application. It is recommended to use copper piping for all system piping to reduce the possibility of the formation of deposits, which may result in heat exchanger starvation.

System pipe size must be in accordance with Table 10, and between supply and return lines, must not exceed 50 feet of equivalent length. Connection sizes at the heater are given in Tables 3 & 5. Any reduction in recommended pipe size may decrease flow resulting in high temperature rise across the heat exchanger, boiler noise, flashing to steam and non-warrantable heat exchanger damage.

Table 10: Minimal System Pipe Size

Input [BTU/hr]	Water Size, NPT [in.]
80,000	1
100,000	1
150,000	1
199,000	1 1/4
250,000	1 1/4
299,000	1 1/2
399,000	2
500,000	2
600,000	2
700,000	2
800,000	2

4.5 HEAT EXCHANGER

This appliance uses precision formed stainless steel tubing to maximize the heat transfer process and to achieve 97% steady-state efficiency. The DynaMax HS is designed to withstand 160 PSIG working pressure.

A factory installed circulating pump ensures proper water flow during burner operation and creates enough velocity inside the stainless steel tubes and headers that prevents scaling.

Installing a strainer upstream of the heat exchanger will reduce the likelihood of tubes from being blocked by debris.

4.6 LOW WATER TEMPERATURE SYSTEMS

In applications where the heating system requires supply water temperatures below 110°F, connections may be made directly to the DynaMax HS. At incoming temperatures of 80°F or lower the DynaMax HS achieves maximum efficiency. Inlet temperatures must not drop below 40°F to prevent freezing.

4.7 PIPING ARRANGEMENTS

4.7.1 Field Supplied Components

- 1) **Boiler system piping**
Boiler system piping MUST be sized according to Table 10. Reducing the pipe size can restrict the flow rate through the boiler, causing boiler damage and will void the manufacturer's warranty.
- 2) **Isolation Valves**
Use only full port ball valves. Failure to supply full port ball valves may result in reduced flow rate through the boiler, causing boiler damage and will void the manufacturer's warranty.
- 3) **Anti-Scald Mixing Valve**
An anti-scaled mixing valve is recommended when DHW storage is above 120°F.
- 4) **Unions**
Recommended for ease of serviceability.
- 5) **System Temperature Sensor**
A system temperature sensor is to be installed in the main header at a point to detect controlled temperature and where it will not lead to short-cycling of the boiler.

An instantaneous water heater is designed to deliver hot water without the use of a storage tank. It is suitable for applications with variable load such as restaurants,

condominiums, apartments and motels and typically used in conjunction with tempering valves to achieve temperature control.

Table 11: Flow and Pressure Drop at a Given Temperature Rise (Hydronic Heating)

Input, Btu/Hr	30 °F (16.7 °C) Temp Rise		35 °F (19.4 °C) Temp Rise	
	USGPM (min. flow)	ΔP Ft.	USGPM (min. flow)	ΔP Ft.
	5.0	8.2	4.3	6.2
100,000	6.3	12.3	5.4	9.4
150,000	9.5	10.4	8.1	7.8
199,000	12.6	7.2	10.8	5.8
250,000	15.8	11.5	13.5	8.7
299,000	18.9	9.3	16.2	7.0
399,000	25.2	8.4	21.6	6.3
500,000	31.5	9.2	27.0	6.9
600,000	38.8	17.5	32.0	11.8
700,000	45.3	18.2	40.0	14.4
800,000	51.8	23.5	43.0	16.0

Table 12: Flow and Pressure Drop at a Given Temperature Rise (DHW)

Input, Btu/Hr	20 °F (11.1 °C) Temp Rise	
	USGPM (min. flow)	ΔP Ft.
80,000	7.5	11.5
100,000	9.4	26.9
150,000	14.0	27.8
199,000	19.2	25.9
250,000	23.5	28.3
299,000	28.8	25.8
399,000	38.4	23.9
500,000	48.6	29.4
600,000	57.6	34.2
700,000	70.4	40.0
800,000	77.6	43.2

DynaMax HS Floor Mount Piping Diagrams

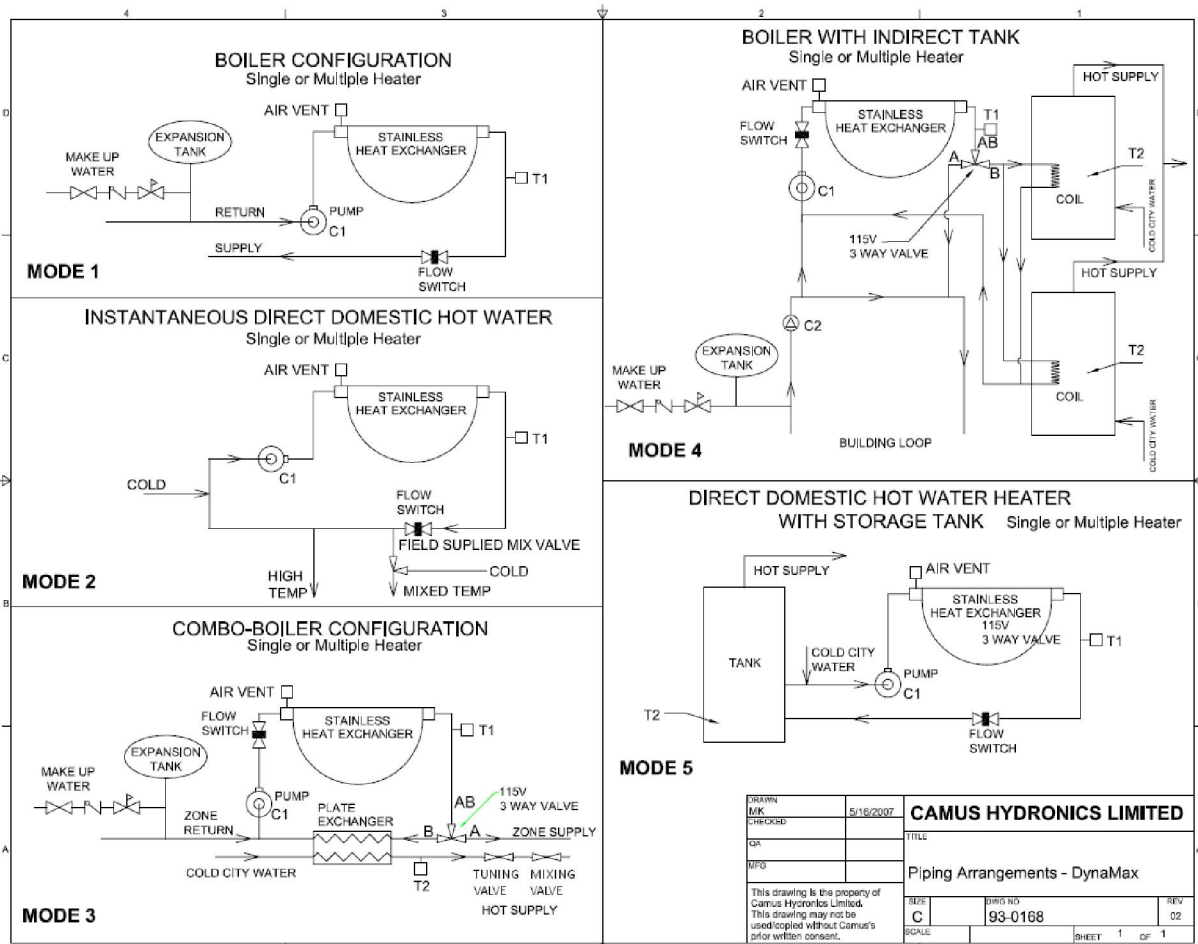

4.8 FLOW PROVING DEVICE (wall mount models and combination models only)

Figure 20: Flow Proving Device



The flow proving device is designed to detect when flow is present. This is done by detecting the amount of current (amperes) that exists in the live wire to the pump. When the current becomes too low a LCI error is displayed indicating a lack of water inside the boiler. The flow proving device is provided on all DynaMax HS wall mount models (DM 80 – 250) and combination floor model units (213 – 803). This switch is factory wired.

Table 13: Flow Proving Device Indicator LED's

LED Illuminated	Symptom
Left (LED1)	Normal operation
Right (LED2)	Current under trip point

When testing the operation of the flow proving device always ensure that 115Vac is being supplied to the pump.

4.9 WATER FLOW SWITCH (Floor mount hydronic and DHW models only)

A paddle style water flow switch is shipped loose and is to be installed in the outlet piping on all floor model heating boilers (DM 211-801) and hot water supply heaters (DM 212 – 802). The flow switch is to be installed in a horizontal run of pipe in order to provide effective contact. The flow switch is to be wired into the DynaMax HS terminal board labelled 'Flow Switch'.

4.10 LOW WATER CUTOFF (If Equipped)

If this boiler is installed above radiation level, a low water cut-off device must be installed at the time of boiler installation. Some local codes require the installation of a low water cut-off on all systems. Electronic low water cut-offs are available as a factory supplied option on all models. Low water cut-offs should be tested every six months. The normally open switch contact of the low water cutoff is to be wired in series with the flow switch. This can be wired into the DynaMax HS terminal labelled 'Flow Switch'.



CAUTION
Remove jumper when connecting to 24 VAC circuit.

Figure 21: Low Water Cut Off Electrical Connections (Watts)

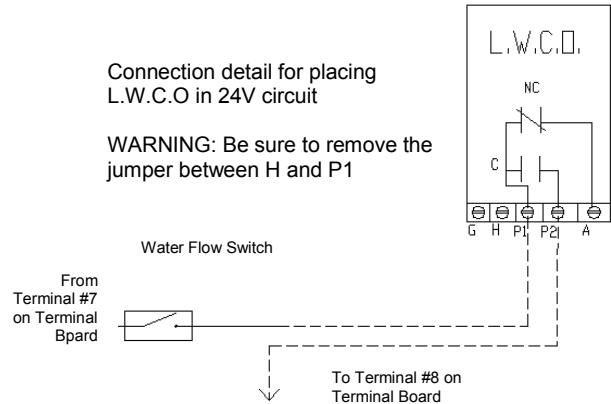
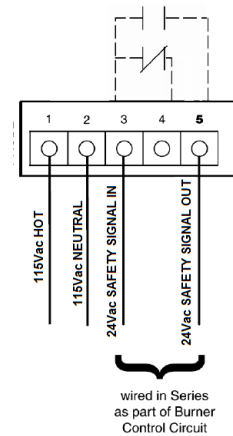

Figure 22: Low Water Cut Off Electrical Connections (ITT)



4.11 RELIEF VALVE

This appliance is supplied with a relief valve sized in accordance with ASME Boiler and Pressure Vessel Code, Section IV ("Heating Boilers"). If this component is shipped loose, no valve is to be placed between the relief valve, and the appliance. To prevent water damage, the discharge from the relief valve shall be piped to a suitable floor drain for disposal when relief occurs. No reducing couplings or other restrictions shall be installed in the discharge line. The discharge line shall allow complete drainage of the valve and line. Relief valves should be manually operated at least once a year.

CAUTION
Avoid contact with hot discharge water

4.12 DHW TUNING VALVE (combination models only)

A DHW tuning valve is provided with all DynaMax HS combination models. In cases where flow control is not possible by the end user the DHW tuning valve is designed to act as a maximum flow controller. The tuning valve is designed to provide the correct amount of hot water for each particular DynaMax HS model and application. Refer to section 10.9 Domestic Hot Water with Plate Heat Exchanger for further details.

PART 5 ELECTRICAL & CONTROLS

⚠ DANGER

IT IS EXTREMELY IMPORTANT THAT THIS UNIT BE PROPERLY GROUNDED!

5.1 ELECTRICAL CONNECTIONS

Table 14: DynaMax HS Electrical Requirements

DynaMax HS Maximum Amp Draw			
Model	Voltage Requirement	Full Load Amps [Amperes]	Maximum Over Current Protection [Amperes]
81, 82, 83	120VAC, 60Hz, Single Phase	4	15
101, 102, 103		4	15
151, 152, 153		4	15
201, 202, 203		4	15
211, 212, 213		4	15
251, 252, 253		4	15
261, 262, 263		4	15
291, 292, 293		4	15
391, 392, 393		4	15
501, 502, 503		4	15
601, 603		4	15
701, 703		6	15
801, 803		6	15
602, 702, 802	230VAC, 60Hz, Single Phase	8	15

The appliance, when installed, must be electrically grounded in accordance with the requirements of the authority having jurisdiction or in the absence of such requirements, with the latest edition of the National Electrical Code ANSI/NFPA No. 70. When the unit is installed in Canada, it must conform to the Canadian Electrical Code, C22.1, Part 1 and/or local Electrical Codes.

- All wiring between the appliance and field installed devices shall be made with wire having minimum 220°F (105°C) rating.
- Line voltage wire exterior to the appliance must be enclosed in approved conduit or approved metal clad cable.
- The pump must run continuously when appliance is being fired.
- To avoid serious damage, DO NOT ENERGIZE the appliance until the system is full of water. Ensure that all air is removed from the pump housing and piping before beginning initial operation. Serious damage may result if the appliance is operated without proper flow.
- Provide the appliance with proper overload protection.
- All wires being placed into the terminal block should be horizontal for at least an inch to ensure sufficient electrical conductivity.

5.2 HIGH LIMIT

A manual reset fail-safe high limit aqua-stat control is inside the appliance and the control bulb is installed in a dry well in the heat exchanger outlet. The setting of this control limits maximum discharge water temperature to 210°F (CPVC, AL29-4C, Stainless) and 185°F (PVC). The temperature of the outlet water in the heat exchanger must drop a minimum of 30°F (16.7°C) below the setting of the high limit control before the reset function can be activated.

5.3 DYNAMAX HS CONTROLLER

This appliance uses a direct spark ignition control system. The operation of the DynaMax HS Controller for the direct spark igniter proves the presence of main flame using a flame sensor proof current (0.8µA). A status of Ignition Failed will be displayed on the main panel if the boiler fails to light after three (3) consecutive ignition attempts.

Figure 23: DynaMaxHS Controller

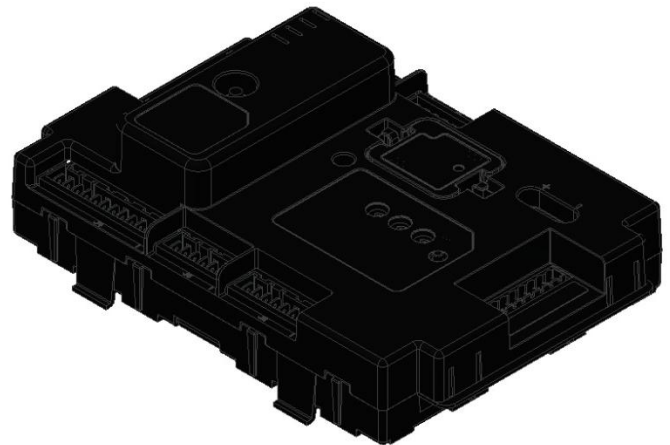

Table 15: Connector Description

Connector	Connector Description
J1	Flame Sensor, Ground Rod
J2	Fan Modulation
J3	Display, Lead lag, Modbus Comm.
J4	24VAC Power, Pump, VFD
J5	Gas Valve, Interlock
J6	Safety Annunciation, Alarm, LCI
J8	24VAC Power, Inlet, Outlet Sensor
J9	DHW, Stack Sensor

5.3.1 SERVICE PARTS

The DynaMax HS Controller is not repairable. Any modification or repairs will invalidate the warranty and may create hazardous conditions that result in property damage, personal injury, fire, explosion and/or toxic gases. A faulty direct spark igniter **MUST** be replaced with a new factory part. **DO NOT** use general purpose field replacement parts. Each appliance has one DynaMax HS Controller, one direct spark igniter and one flame sensor. A list of recommended spare parts is illustrated in parts breakdown in this manual.

5.3.2 IGNITION MODULE LOCKOUT FUNCTIONS

The DynaMax HS Controller may lockout in either a manual reset condition requiring pushing the reset button to recycle the control for a CSD1 requirement or an automatic reset condition. Pushing the “OK” with the control in a hard lockout condition is the only way to reset the DynaMax HS Controller. Turning the main power “OFF” and then “ON” or cycling the thermostat will not reset a hard lockout condition. Wait until the display has synchronized before pushing the “OK” button to clear a manual reset condition.

The DynaMax HS Controller may proceed into a soft lockout condition. The boiler will stay in the automatic reset state until the fault is corrected and will automatically return to normal operating state.

5.4 ERROR TABLE

5.4.1 Manual Reset Codes

Table 16: Manual Reset Codes*

#	Description
0	None
1-31	Internal hardware error
47	Flame rod to ground leakage
49	24VAC low/high
64	Fan speed not proved, ignition failure
67	ILK Off
79	Heater Outlet high limit tripped
91	Inlet sensor fault
92	Outlet sensor fault
93	DHW sensor fault
95	Stack sensor fault
96	Outdoor sensor fault
105	Flame detected out of sequence
106	Flame lost in Main Flame Establishing Period (MFEP)
107	Flame lost early in run
108	Flame lost in run
109	Ignition failed
112	Pilot test flame timeout
113	Flame circuit timeout
149	Flame detected

* To eliminate the hard lockout error,

- 1) Press the **OK** button to clear the error on screen

5.4.2 Automatic Reset Codes

Table 17: Automatic Reset Codes

#	Description
0	None
29	Burner switch turned OFF
30	Burner switch turned ON
47	Flame rod to ground leakage
49	Abnormal 24Vac voltage
50	Modulation Fault
61	Anti-short Cycle
62	Fan speed not proved
67	Interlock Off, safety circuit is open
69	Pilot test hold
78	Demand lost in run
79	Outlet high limit tripped (internal limit)
81	Delta-T limit exceeded (30°F)
91	Inlet sensor fault
92	Outlet sensor fault
93	DHW sensor fault
95	Stack sensor fault
96	Outdoor sensor fault
97-99	Internal Fault
128	Fan speed failed during prepurge
129	Fan speed failed during preignition
130	Fan speed failed during ignition
131	Fan movement detected during standby
132	Fan speed failed during run
137	Interlock failed to close, safety circuit is open
110	Ignition failure occurred
111	Flame current below threshold (0.8Vdc)
149	Flame detected
150, 291	Flame not detected
301	Interlock Off, safety circuit is open
-	
310	
353	Stack limit (PVC: 149°F, CPVC: 194°F, PPE: 230°F, SS, AL29-4C: 250°F)
460	LCI lost in run, safety circuit is open
614	Lead boiler was rotated based on measured run time

PART 6 CONTROL PANEL

6.1 DYNAMAX HS CONTROLLER

The appliance is provided with an operator interface panel at the front. On a DynaMax HS Wall Hung boiler the DynaMax HS Controller can be accessed by removing the upper stainless steel jacket and the lower black sheetmetal jacket which are each held on by two (2) screws. On a DynaMax HS Floor Mount boiler the DynaMax HS Controller can be accessed by carefully lifting off the black-coloured top cover which is held on by four (4) snap lock fasteners.

6.2 SETTING THE DYNAMAX HS CONTROLLER



Button	Description
	Back button to return to previous menu
	Information button
	Home Button returns screen to home screen
	Navigation buttons
	Confirm selection

The 5-way control pad allows for easy access to various functions on the DynaMax HS controller. A button allows for immediate information concerning boiler operation including temperatures, boiler status and any errors that are occurring.

The Boiler Temperature Controller for this appliance is the Honeywell SOLA. It initiates the local call for heat and sets the target return (appliance inlet) water temperature. This controller offers a range of operation modes which provides set point as well as modulating control. It provides the following:

- Readings of inlet and outlet water temperatures as well as flame signal.
- Operation as an auto reset limit.
- Operation as a control for inlet water temperature, outlet temperature, system temperature.
- Available tank mounted sensor used in conjunction with inlet sensor.
- Adjustable; target temp, inter-stage differential, on delay between stages, minimum on time per stage, minimum off time per stage.
- Flame failure signal.
- Error message display in text
- Manual override of boiler input rate for combustion
- Pump exercising feature runs pump 10 seconds every three days in the event of no pump operation.

Levels of Access

Two levels of access to simplify the use of the boiler.

User – Access to general boiler and display settings and adjustments to the central heating, domestic hot water and lead lag setpoint.

Installer – Access to all user parameters and allows for changes to additional boiler parameters to allow for ease of startup and serviceability.

The screenshot below displays the default homescreen.

Figure 24: Home Screen

System setpoint 182 °F
Operating temp 77 °F
Outlet temp 77 °F
Inlet temp 52 °F
Outdoor temp 20 °F

Boiler name Boiler 1
 State Standby
 Demand Burner switch off
 Access status User

Alert 29 Burner switch was turned OFF

Press OK to clear alert

The first five parameters can be user customizable to reflect the most vital information required on the boiler. The list of available parameters is outlined in the table below. This can be done by pressing:

- 1)
- 2) Scroll to *Display Setup*, press **OK**
- 3) Select the line item that is required to be altered, press **OK**
- 4) Select parameter, and press **OK**

PARAMETER	DESCRIPTION
Standard parameters	
System setpoint	Indicates active setpoint
Operating temp	Indicates temperature at modulation sensor (Default: inlet sensor)
Outlet	Outlet Water Temperature [°F]
Inlet	Inlet Water Temperature [°F]
Outdoor	Outdoor Temperature [°F], if equipped
Additional user configurable parameters	
Delta T	Outlet and Inlet water temperature differential [°F]
LL Operating Temp	Indicates temperature at modulation sensor, if equipped (Default: S5: system sensor)
LL system setpoint	Indicates active lead lag setpoint
Fan speed	Actual fan speed [RPM]
Flame signal	Actual flame signal [Vdc]
Firing Rate	Target fan speed [RPM]
DHW	DHW Temperature [°F], if equipped
Stack	Stack Temperature [°F], if equipped
4-20mA	4-20mA input, if equipped

PARAMETER	DESCRIPTION
Boiler name	DynaMax HS model
State	Indicates current boiler operation sequence
Demand	Indicates origin of call for heat (CH, DHW, Lead Lag)
Access Status	User, Installer
Outdoor	Outdoor Temperature [°F], if equipped
Error	Alert or Lockout. Section 5.4 provides additional details.

Pressing provides additional troubleshooting information on the diagnostic screen.

Figure 25: Diagnostic Screen

Boiler pump (C)	Off
CH pump (A)	Off
DHW pump (B)	Off
Blower/HSI	Off
External ignition	Off
Pilot valve	Off
Main valve	Off
Alarm	Off
Interlock (ILK)	On
Pre-ignit interlock (PII)	Off
Load Control Input (LCI)	On
STAT (Demand)	On
Time Of Day	Off
Safety relay	Off

PARAMETER	DESCRIPTION
Boiler pump	Pump A
Auxiliary Pump	Pump B. 3-way valve diverter operation
DHW Pump	Pump C. Additional contact rated for 1/6hp.

Sequence of Operation

- STAT
 - Pump A Pump B Pump C
 - LCI
 - Interlock
 - Pilot Valve
- Pump A: DynaMax Pump
 Pump B: 3-way diverter valve, if equipped
 Pump C: DHW Pump, if equipped
 Open
 Closed

Pump A is energized for any call for heat
 Pump B is energized on CH
 Pump C is energized on DHW

LCI:

- Flow Switch (N/O)
- LWCO (N/O, if equipped)
- Front Thermal Fuse (N/C)
- Rear Thermal Fuse (N/C)
- Blocked Flue Switch (N/C)

Interlock:

- High Limit (N/C)
- Low gas switch (4.5" w.c., N/O)
- High gas switch (14" w.c., N/C)

Pressing provides additional temperature information.

Figure 26: Temperature screen

Outlet temp	77 °F
Inlet temp	52 °F
Delta T	25 °F
DHW temp	76 °F
Stack temp	102 °F
Outdoor temp	20 °F
Fan speed	LOW
Flame signal	0.00 uA
Firing rate	0 RPM
4-20mA input	OPEN
System sensor	Outlet

Intermittent Pump Electrical Connection

Terminals 7 and 8: 115Vac relay coil
 Terminals 4 and 6: Normally open contacts

Pump Delay Relay

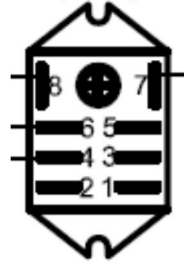

Constant Pump Operation Electrical Connection

Place black wire #16 on terminal 5. This will provide 115Vac to the DynaMax pump continuously.

Central Heat Programming Instructions

Modulation: Boiler Inlet, Boiler Fixed Setpoint Operation (Standalone)

Description	Electrical Connection(s)	Programming Instructions
<ul style="list-style-type: none"> Boiler operates at a fixed setpoint Modulates on boiler inlet sensor (default) Heat demand is generated when Remote Operator is closed. 		<ol style="list-style-type: none"> Place both toggle switches to LOCAL Press i and select <i>Login</i>, Select <i>Quick Start</i> <ol style="list-style-type: none"> Select <i>CH Setpoint</i>, and enter desired setpoint using 5-way control <p>The setpoint can be chaged on screen by using the ▲ or ▼ buttons and press OK</p> <ol style="list-style-type: none"> Place Local/Remote switch to REMOTE for remote enable operation (if required)

Modulation: Boiler Inlet, Outdoor Reset Operation (Standalone)

Description	Electrical Connection(s)	Programming Instructions
<ul style="list-style-type: none"> Boiler operates with variable setpoint determined by outdoor reset curve Modulates on inlet sensor (default) Heat demand is generated when Remote Operator is closed. 		<ol style="list-style-type: none"> Place both toggle switches to LOCAL Press i and select <i>Login</i> Select <i>Advanced Setup</i> <div style="display: flex; justify-content: space-around; align-items: center; margin: 10px 0;"> <div style="text-align: center;"> <p>Quick Start</p> <p>Test</p> <p>Diagnostics</p> </div> <div style="text-align: center;"> <p>Login</p> <div style="background-color: black; color: white; padding: 5px; border: 1px solid black; margin: 5px;"> Advanced Setup </div> <p>Display Setup</p> </div> <div style="font-size: 2em; color: purple; margin-left: 10px;">←</div> </div> Select <i>CH Config</i> Select <i>Outdoor Reset Config</i> Select <i>Outdoor Reset</i> and Press OK and select <i>Enable</i> Set <i>Max outdoor temp</i> (Warm weather shutdown, WWSD) Set <i>Min outdoor temp</i> (Outdoor Design) Set <i>Low Water temp</i> (Min. Water Temp.) Set <i>Outdoor boost max off point</i> (Design Max.) Select <i>Sensor Configuration</i> Select <i>Outdoor temp src</i> and Press OK Select <i>S5</i> and Press OK Place right hand toggle switch to REMOTE for remote operation (if required)

Modulation: System Sensor, Outdoor Reset Operation (Standalone)

NOTE: Outdoor Reset Module (PN: W8735S1000) required.

Description	Electrical Connection(s)	Programming Instructions																										
<ul style="list-style-type: none"> Boiler operates with variable setpoint determined by outdoor reset curve Modulates on system sensor Heat demand is generated when Remote Operator is closed. 	<table border="1"> <tr> <td rowspan="2">Remote Operator</td> <td>5</td> <td></td> </tr> <tr> <td>6</td> <td></td> </tr> <tr> <td rowspan="2">Flow Switch</td> <td>7</td> <td></td> </tr> <tr> <td>8</td> <td></td> </tr> <tr> <td rowspan="2">Outdoor System Sensor</td> <td>9</td> <td></td> </tr> <tr> <td>10</td> <td></td> </tr> <tr> <td rowspan="2">4-20mA</td> <td>11 (+)</td> <td></td> </tr> <tr> <td>12 (-)</td> <td></td> </tr> </table>	Remote Operator	5		6		Flow Switch	7		8		Outdoor System Sensor	9		10		4-20mA	11 (+)		12 (-)		<ol style="list-style-type: none"> Connect Remote Operator Connect System sensor to System/Outdoor contacts Connect Outdoor Sensor to J3 ECOM connector Place both toggle switches in LOCAL Press and select <i>Login</i> Select <i>Advanced Setup</i> <div style="text-align: center;"> <p>Advanced Setup</p> <table border="0"> <tr> <td>Quick Start</td> <td>Login</td> </tr> <tr> <td>Test</td> <td>Advanced Setup ←</td> </tr> <tr> <td>Diagnostics</td> <td>Display Setup</td> </tr> </table> </div> <ol style="list-style-type: none"> Select <i>CH Config</i> Select <i>Outdoor Reset Config</i> Select <i>Outdoor Reset</i> and Press OK and select <i>Enable</i> Set <i>Max outdoor temp</i> (Warm Weather shutdown, WWSD) Set <i>Min outdoor temp</i> (Outdoor Design) Set <i>Low Water temp</i> (Min. Water Temp.) Set <i>Outdoor boost max off point</i> (Design Max.) Select <i>Sensor Configuration</i> Select <i>Outdoor temp src</i> and Press OK Select <i>EnviraCOM</i> and Press OK Select <i>Select CH Config</i> (twice) Select <i>Modulation sensor = S5</i> Place right hand toggle switch to REMOTE for remote operation (if required) 	Quick Start	Login	Test	Advanced Setup ←	Diagnostics	Display Setup
Remote Operator	5																											
	6																											
Flow Switch	7																											
	8																											
Outdoor System Sensor	9																											
	10																											
4-20mA	11 (+)																											
	12 (-)																											
Quick Start	Login																											
Test	Advanced Setup ←																											
Diagnostics	Display Setup																											

4-20mA/ 0-10Vdc Setpoint Operation (Standalone)

Consult Additional Boiler Parameters section in manual on page 33 using parameter address 583 and 584.

4-20mA/ 0-10Vdc Firing Rate Operation (Standalone)

Description	Electrical Connection(s)	Programming Instructions
<ul style="list-style-type: none"> Boiler operates with variable setpoint determined by 4-20mA incoming signal Modulates on header sensor Heat demand is generated when Remote Operator is closed and 4-20mA or 0-10Vdc signal is present. 	<p>The diagram shows a terminal block with 12 terminals. Terminals 5 and 6 are labeled 'Remote Operator'. Terminals 7 and 8 are labeled 'Flow Switch'. Terminals 9 and 10 are labeled 'Outdoor System Sensor'. Terminals 11 and 12 are labeled '+ 4-20mA' and '- 4-20mA' respectively. Red boxes highlight the Remote Operator and 4-20mA connections.</p>	<ol style="list-style-type: none"> Place both toggle switches in LOCAL Press ⓘ and select <i>Login</i> Select <i>Advanced Setup</i> <div style="text-align: center;"> <p>Advanced Setup</p> <p>The diagram shows a menu with options: Quick Start, Login, Test, Advanced Setup (highlighted with a purple arrow), Diagnostics, and Display Setup.</p> </div> Select <i>CH Config</i> Select <i>Modulation rate source = 4-20mA and burner on/off</i> Place right hand toggle switch to REMOTE for remote operation (if required)

Domestic Hot Water Programming Instructions

Modulation: Fixed Setpoint Operation (Standalone)

Description	Electrical Connection(s)	Programming Instructions
<ul style="list-style-type: none"> Boiler operates at a fixed DHW setpoint Modulates on boiler inlet sensor (default) Heat demand is generated when Remote Operator is closed. 	<p>DHW Sensor/ Stat, if required.</p> <p>Terminal block connections:</p> <ul style="list-style-type: none"> DHW Sensor: 13, 14 Alarm: 15, 16 Lead Lag: 17, 18 Modbus: +19, -20 	<ol style="list-style-type: none"> Place both toggle switches in LOCAL Press i and select <i>Login</i> Select <i>Advanced Setup</i> <div style="text-align: center;"> <p>Advanced Setup</p> </div> Select <i>DHW Config</i> <u>Inlet Sensor operation</u> Select <i>Demand switch = Sensor only</i>, and Press OK Select <i>Mod sensor = Inlet</i>, and Press OK, go to step 7 <p><u>DHW Stat operation</u></p> <ol style="list-style-type: none"> Select <i>Demand switch = DHW switch</i>, and Press OK Select <i>Mod sensor = Inlet</i>, and Press OK, go to step 7 <p><u>DHW Sensor operation</u></p> <ol style="list-style-type: none"> Select <i>Demand switch = Sensor only</i>, and Press OK Select <i>Mod sensor = DHW</i>, and Press OK Select <i>DHW Setpoint</i>, and enter desired setpoint using 5-way control Place right hand toggle switch setting to REMOTE for remote operation (if required)

Instantaneous DHW with Brazed Plate Heat Exchanger (combination models)

Description	Electrical Connection(s)	Programming Instructions						
<ul style="list-style-type: none"> Boiler operates at a fixed DHW setpoint Modulates on boiler inlet sensor (default) Heat demand is generated when Remote Operator is closed. 	<p>DHW Sensor, if required.</p>	<ol style="list-style-type: none"> Place both toggle switches in LOCAL Press i and select <i>Login</i> Select <i>Advanced Setup</i> <div style="text-align: center;"> <p>Advanced Setup</p> <table border="0"> <tr> <td>Quick Start</td> <td>Login</td> </tr> <tr> <td>Test</td> <td>Advanced Setup ←</td> </tr> <tr> <td>Diagnostics</td> <td>Display Setup</td> </tr> </table> </div> Select <i>DHW Config</i> Select <i>Demand switch = Plate Heat Exch</i>, and Press OK Select <i>Mod sensor = DHW</i> OK Select <i>DHW Setpoint</i>, , and enter desired setpoint using 5-way control Place right hand toggle switch setting to REMOTE for remote operation (if required) 	Quick Start	Login	Test	Advanced Setup ←	Diagnostics	Display Setup
Quick Start	Login							
Test	Advanced Setup ←							
Diagnostics	Display Setup							

Lead Lag Programming Instructions

Master Boiler

Description	Electrical Connection(s)	Programming Instructions						
<ul style="list-style-type: none"> Master boiler lead lag setup 	<p>DHW Sensor [13, 14] Alarm [15, 16] Lead Lag [17, 18] + 19 - 20 Local Modbus</p>	<ol style="list-style-type: none"> Place both toggle switches in LOCAL Press i and select <i>Login</i> Select <i>Advanced Setup</i> <div style="text-align: center;"> <p>Advanced Setup</p> <table border="0"> <tr> <td>Quick Start</td> <td>Login</td> </tr> <tr> <td>Test</td> <td>Advanced Setup ←</td> </tr> <tr> <td>Diagnostics</td> <td>Display Setup</td> </tr> </table> </div> Select <i>System</i> Select <i>System ID & Access</i> Verify <i>MB1 Modbus address = 1</i> Verify <i>MB2 Modbus address = 1</i> Select <i>CH Config (twice)</i> Select <i>Modulation Sensor = S5</i> Select <i>Lead Lag Config</i> Select <i>Lead Lag Master Config</i> Select <i>Master enable = Enable</i> <u>Fixed Setpoint operation</u> Select <i>Setpoint</i>, and enter desired setpoint using 5-way control <u>4-20mA/ 0-10Vdc setpoint operation</u> <ol style="list-style-type: none"> Select <i>Setpoint Source = 4-20mA</i>, and Press OK Consult <i>Additional Boiler Parameters</i> section in manual on page 33 using parameter address 560 and 561. Select <i>Lead Lag Slave Config</i> Select <i>Slave enable = Enabled via SOLA master</i>, and Press OK 	Quick Start	Login	Test	Advanced Setup ←	Diagnostics	Display Setup
Quick Start	Login							
Test	Advanced Setup ←							
Diagnostics	Display Setup							

Slave Boiler

Description	Electrical Connection(s)	Programming Instructions
<ul style="list-style-type: none"> Slave boiler lead lag setup 	<p>DHW Sensor [13 [* [14 [* [</p> <p>Alarm [15 [* [16 [* [</p> <p>Lead Lag [17 [* [18 [* [</p> <p>+ 19 [* [</p> <p>- 20 [* [</p> <p>Local Modbus</p>	<ol style="list-style-type: none"> Place both toggle switches in LOCAL Press i and select <i>Login</i> Select <i>Advanced Setup</i> <div style="display: flex; justify-content: space-around; align-items: center;"> <div style="text-align: center;"> <p>Quick Start</p> <p>Test</p> <p>Diagnostics</p> </div> <div style="text-align: center;"> <p>Login</p> <div style="background-color: black; color: white; padding: 5px; margin: 5px;"> Advanced Setup </div> <p>Display Setup</p> </div> <div style="text-align: center;"> <p>←</p> </div> </div> <ol style="list-style-type: none"> Select <i>System</i> Select <i>System ID & Access</i> Select <i>MB1 Modbus address = 2</i>. To be in sequential order Select <i>MB2 Modbus address = 2</i>. To be in sequential order Select <i>Lead Lag Config</i> Select <i>Lead Lag Slave Config</i> Select <i>Slave enable = Enabled via SOLA master</i>, and Press OK

Outdoor Sensor connected to Slave boiler 2 (DRH ONLY)

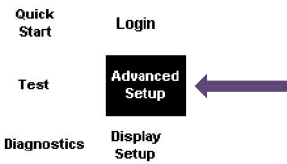
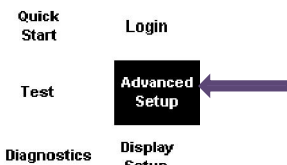
Description	Electrical Connection(s)	Programming Instructions																																
<ul style="list-style-type: none"> Slave boiler outdoor sensor configuration When done correctly, the outdoor temperature will be shown on the Master boiler 	<table border="1"> <tr> <td>Remote Operator</td> <td>[5</td> <td>⊗</td> <td></td> </tr> <tr> <td></td> <td>6</td> <td>⊗</td> <td></td> </tr> <tr> <td>Flow Switch</td> <td>[7</td> <td>⊗</td> <td></td> </tr> <tr> <td></td> <td>8</td> <td>⊗</td> <td></td> </tr> <tr> <td>Outdoor System Sensor</td> <td>[9</td> <td>⊗</td> <td></td> </tr> <tr> <td></td> <td>10</td> <td>⊗</td> <td></td> </tr> <tr> <td>+</td> <td>11</td> <td>⊗</td> <td></td> </tr> <tr> <td>4-20mA -</td> <td>12</td> <td>⊗</td> <td></td> </tr> </table>	Remote Operator	[5	⊗			6	⊗		Flow Switch	[7	⊗			8	⊗		Outdoor System Sensor	[9	⊗			10	⊗		+	11	⊗		4-20mA -	12	⊗		<p><u>Slave Boiler</u></p> <ol style="list-style-type: none"> Place both toggle switches in LOCAL Press ⓘ and select <i>Login</i> Select <i>Advanced Setup</i>  <ol style="list-style-type: none"> Select <i>Sensor Configuration</i> Select <i>Outdoor temp src</i> and Press OK Select <i>S5</i> and Press OK <p><u>Master Boiler</u></p> <ol style="list-style-type: none"> Place both toggle switches in LOCAL Press ⓘ and select <i>Login</i> Select <i>Advanced Setup</i>  <ol style="list-style-type: none"> Select <i>Lead Lag Config</i> Select <i>Lead Lag Outdoor Reset</i> Select <i>Outdoor reset enable = Enable</i> and press OK Set <i>Max outdoor temp</i> (Warm weather shutdown, WWSD) Set <i>Min outdoor temp</i> (Outdoor Design) Set <i>Low Water Temp</i> (Min. Water Temp.) Set <i>Outdoor boost maximum off point</i> (Design Max.) Select <i>CH Config</i> Select <i>Warm weather shutdown</i> Select <i>Warm weather shutdown = Shutdown after demand has ended</i> and
Remote Operator	[5	⊗																																
	6	⊗																																
Flow Switch	[7	⊗																																
	8	⊗																																
Outdoor System Sensor	[9	⊗																																
	10	⊗																																
+	11	⊗																																
4-20mA -	12	⊗																																

press **OK**
20) Select *Warm weather shdn setpoint*

Base load rate adjustment

Description	Electrical Connection(s)	Programming Instructions
<ul style="list-style-type: none"> Upon a call for heat the lead boiler will fire to the specified base load rate (80%). If the temperature is not within Error threshold (5°F) of setpoint after Interstage delay (2 minutes) a lag boiler will be brought online and will also fire at the base load rate specified. Modulation of boilers will only occur after all boilers in the Lead Lag system are firing at the specified base load rate (80%). 		<ol style="list-style-type: none"> Place both toggle switches in LOCAL Press i and select <i>Login</i> Select <i>Advanced Setup</i> <div style="text-align: center;"> </div> <ol style="list-style-type: none"> Select <i>Lead Lag Config</i> Select <i>Lead Lag Master Config</i> Select <i>Base load common rate = 80.0%</i>, and press OK

Additional Boiler Parameter Instructions

There are some parameters that are not accessible through the Advanced Setup within the HAPI display.

Temperature related parameters must be entered in degrees Celsius. For example, 50°F = 10.0°C. The value “100” is entered into the display. Refer to the next page for a conversion table.

Safety related parameters should not be altered as this will send the control into a Lockout 2 condition, and the HAPI display cannot recover from this. If such an issue arises, the R7910B1009 Honeywell SOLA ignition control must be replaced.

Press > *Advanced Setup* > *System Config* > *System Config* > *General Config*

General Config

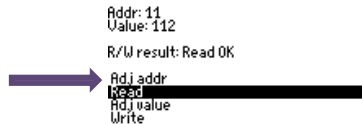

- 1) Locate the parameter that requires adjustment and cross reference with Address Number in the table below
- 2) Select *Adj addr* > Enter desired address number > Select *OK*
- 3) Select *Read* and press . Check on screen R/W result: Read OK
- 4) Select *Adj value* > Enter desired value > Select *OK*
- 5) Select *Write* and press

Parameter	Address #	Parameter Value
Lead Lag Parameters		
Lead Lag modulation back up sensor	559	0 = No backup sensor 1 = Outlet sensor from lead boiler (Default) 2 = Average outlet sensor from all slave boilers
Lead Lag CH 4mA water temperature	560	-40 – 130°C, (Default: 160°F = 71°C)
Lead Lag CH 20mA water temperature	561	-40 – 130°C, (Default: 160°F = 38°C)
Lead selection method	574	1 = equalize run time (default)
Lag selection method	575	0 = sequence order 1 = equalize run time (default)
Add-stage error threshold	718	0 – 130°C, (Default: 5°F = 3°C)
Add-stage inter-stage delay	722	0-64800 seconds, (Default: 120 seconds)
Drop-stage threshold	727	0 – 130°C, (Default: 5°F = 3°C)
Drop-stage inter-stage delay	731	0-64800 seconds, (Default: 120 seconds)
Lead rotation time	733	0-64800 minutes, (Default: 60 minutes)
Standalone Parameters		
CH Enable	208	0 = Disabled, 1 = Enabled
DHW Enable	448	0 = Disabled, 1 = Enabled
DHW Demand Switch	449	0 = Sensor only, 2 = DHW Stat, 9 = Plate Heat Exchanger
CH Demand Switch	556	0 = Room Stat, 7 = Modulation Sensor
CH 4mA water temperature	583	-40 – 130°C, (Default: 160°F = 71°C)
CH 20mA water temperature	584	-40 – 130°C, (Default: 160°F = 38°C)
DHW priority time	452	0 = Disabled (Default) >0 = DHW priority time (seconds) After this timer has expired the heater will revert to CH demand
DHW priority source	463	0 = Disabled (Default) 1 = Enables DHW priority algorithm
Preferred Lightoff Rate	666	2500 – 3000 RPM (Default: 3000 RPM)
Combination Parameters		
Plate preheat setpoint	689	-40 – 130°C, (Default: 120°F = 49°C)
Plate preheat on hysteresis	691	-40 – 130°C, (Default: 5°F = 3°C)
Plate preheat off hysteresis	692	-40 – 130°C, (Default: 5°F = 3°C)
Plate preheat minimum on time	693	0 – 64800 seconds, (Default: 60 seconds)
Tap detect degrees	694	Rate of temperature drop in DHW sensor when tap detection is declared 0 – 130°C, (Default: 2°F/ second = 1.1°C/second)
Tap stop DHW-Inlet degrees	697	ΔT between DHW and Inlet when tap demand is stopped. (Default: 10°F = 6°C) For an indirect storage tank, use 20°F = 11.1°C
Tap stop Outlet-Inlet degrees	698	ΔT between Outlet and Inlet when tap demand is stopped. (Default: 4°F = 6°C) For an indirect storage tank, use 2°F = 1.1°C
Tap detect on threshold	700	When DHW reaches this temperature, heater activates DHW tap algorithm (Default: 115°F = 46°C)

Parameter	Address #	Parameter Value
Pump Parameters		
DHW Pump Options 1	298	320
DHW Pump Options 2	299	49153
Boiler Pump Options 1	300	258
Boiler Pump Options 2	301	49153
Auxiliary Pump Options 1	753	800
Auxiliary Pump Options 2	754	16385
Ignition Parameters		
Preferred Lightoff Rate	666	3000

Fahrenheit [°F]	Celcius [°C]	Enter Into Display
-20	-28.9	-289
-10	-23.3	-233
0	-17.8	-178
10	-12.2	-122
20	-6.7	-67
30	-1.1	-11
40	4.4	44
50	10.0	100
60	15.6	156
70	21.1	211
80	26.7	267
90	32.2	322
100	37.8	378
110	43.3	433
120	48.9	489
130	54.4	544
140	60.0	600
150	65.6	656
160	71.1	711
170	76.7	767
180	82.2	822
190	87.8	878
200	93.3	933

Boiler Setup Programming Instructions

Adjust stack limit

Description	Programming Instructions
<ul style="list-style-type: none"> Adjust stack limit based on vent material used PVC: 149°F CPVC: 194°F PP, AL29-4C, Stainless steel: 230°F 	<ol style="list-style-type: none"> Place both toggle switches in LOCAL Press ⓘ and select <i>Login</i> Select <i>Quick Start</i> <div style="text-align: center;"> <p>Quick Start</p> </div> Select <i>Adjustable Stack limit</i>, and enter desired stack limit rate using 5-way control and press OK

Adjust outlet high limit

Description	Programming Instructions
<ul style="list-style-type: none"> Adjust outlet high limit 	<ol style="list-style-type: none"> Place both toggle switches in LOCAL Press ⓘ and select <i>Login</i> Select <i>Quick Start</i> <div style="text-align: center;"> <p>Quick Start</p> </div> Select <i>Adjustable high limit</i>, and enter desired stack limit rate using 5-way control and press OK

Alter Homescreen Parameters

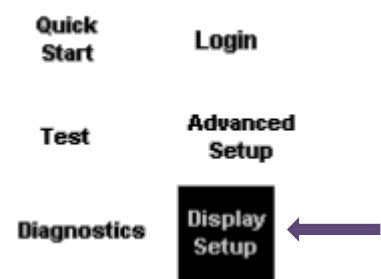
Description	Programming Instructions
<ul style="list-style-type: none"> To adjust one of five read only parameters on the homescreen <p>Home screen line 1: System setpoint 182 °F</p> <pre> System setpoint 182 °F Operating temp 77 °F Outlet temp 77 °F Inlet temp 52 °F Outdoor temp 20 °F Delta T -25 °F LL Operating temp -40 °F LL System setpoint 150 °F Fan speed LOW Flame signal 0.00 uA Firing rate 0 RPM DHW temp 76 °F Stack temp 102 °F 4-20mA input OPEN </pre>	<ol style="list-style-type: none"> Place both toggle switches in LOCAL Press ⓘ and select <i>Display Setup</i>  <p>The diagram shows a menu with the following items: Quick Start, Login, Test, Advanced Setup, Diagnostics, and Display Setup. The 'Display Setup' item is highlighted with a black background and a purple arrow points to it from the right.</p> <ol style="list-style-type: none"> Select Line that needs to be changed and press OK

View burner run time, pump cycles

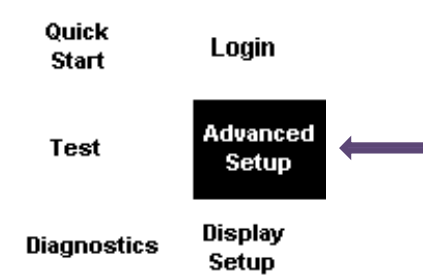
Description	Programming Instructions
<ul style="list-style-type: none"> To view burner run time, pump cycles for maintenance and service purposes 	<ol style="list-style-type: none"> Place both toggle switches in LOCAL Press ⓘ and select <i>Login</i> Select <i>Advanced Setup</i>  <p>The diagram shows a menu with the following items: Quick Start, Login, Test, Advanced Setup, Diagnostics, and Display Setup. The 'Advanced Setup' item is highlighted with a black background and a purple arrow points to it from the right.</p> <ol style="list-style-type: none"> Select <i>System Config</i> Select <i>Statistics Config</i>

PART 7 COMPONENTS

7.1 DIRECT SPARK IGNITER

The direct spark igniter is inserted directly through the combustion chamber front door and held in place by two torx-20 screws which must be torqued to 1 ft-lb (1.4 Nm). Care must be taken when removing and/or installing the igniter. Always remove the igniter prior to removing the fan assembly for inspection of the burner and heat exchanger.

When replacing the igniter do not over tighten the mounting screws. Torque the screws to no more than 10 in-lb.

Figure 27: Direct Spark Igniter

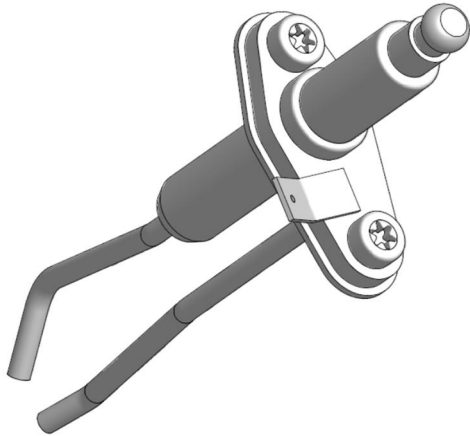

During a trial for ignition sequence a properly operating igniter will generate a continuous spark with a 13/64" (5.2mm) spark gap. It is recommended to clean the direct spark igniter using steel wool as required. **DO NOT** use sandpaper or grit-cloth since this will contaminate the metal surface.

7.2 FLAME SENSOR

The flame sensor is inserted directly through the combustion chamber front door and is screwed into the combustion chamber front door by torx-20 screws. Care must be taken, when installing the flame sensor, to align it perpendicular to the fan flange and parallel to the burner tube and not to over tighten.

Figure 28: Flame Sensor

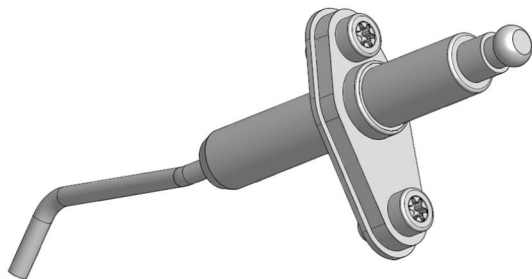

The ignition module relies on the flame sensor to provide a flame rectification signal. Oxide deposits, improper placement or damaged ceramic insulator will result in insufficient signal leading to ignition module lock out. For proper operation minimum 0.8Vdc must be fed back to the module. Oxide deposit on the sensor rod must be removed with steel-wool. **DO NOT** use sand-paper or grit-cloth since this will contaminate the metal surface.

7.3 COMBUSTION AIR FAN

DynaMax HS uses a modulating air fan to provide combustible air/gas mix to the burner and push the products of combustion through the heat exchanger and venting system. The fan assembly consists of a sealed housing and fan wheel constructed from spark resistant cast aluminum. The fan is operated by a fully enclosed 120 VAC, Single-Phase EC/DC electric motor. The fan housing and motor assembly is fully sealed and **SHOULD NOT** be field serviced. The power draw of the motor is proportional to the modulated gas input rate of the appliance.

7.4 GAS VALVE

Figure 29: DynaMax HS 80 -250/260 Gas Valve

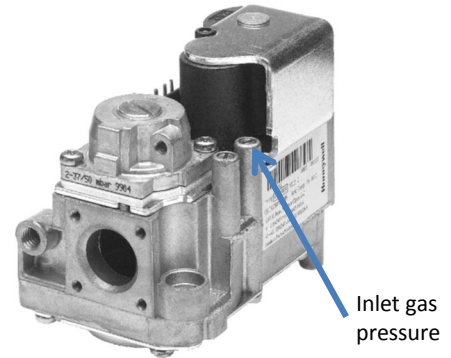
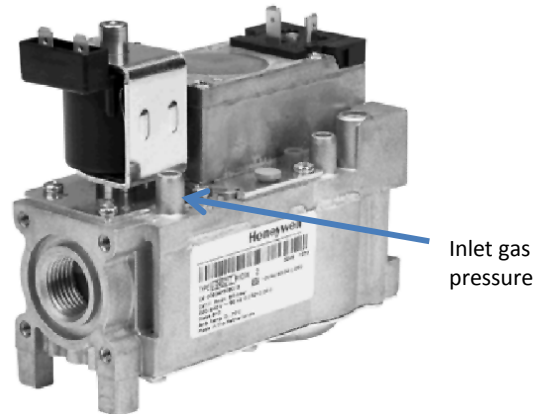

Figure 30: DynaMax HS 299 -399 Gas Valve



The gas valve supplied with the DynaMax HS boiler is a combined valve/venturi assembly. A servo pressure regulator is incorporated into the gas valve to provide stable gas supply. Pressure taps are provided to check inlet and outlet gas pressures. An internal fine mesh screen is incorporated in the inlet of the gas valve to prevent debris from entering the combustion chamber. Gas valves are factory set at low and high fire and modulates to maintain combustion characteristics across the full operating range.

7.5 OUTER JACKET

The outer jacket assembly is constructed from mirror finish stainless steel. This ensures a long life for the jacket assembly, with full integrity

PART 8 TROUBLESHOOTING

Table 18: Troubleshooting Table

COMPONENT	FAILURE MODE	ANALYSIS
Incoming Power	<ul style="list-style-type: none"> Two wires interchanged 	<ul style="list-style-type: none"> No effect on safety Live and Neutral wires are interchanged.
Transformer Tripped	<ul style="list-style-type: none"> The 24Volts and 120 Volts wired are interchanged 	<ul style="list-style-type: none"> Transformer immediately burns out, replace transformer
Pump Fails to Circulate	<ul style="list-style-type: none"> Wiring Issue 	<ul style="list-style-type: none"> Check that wires are correctly wired from the DynaMax HS Controller to the pump delay relay. Check that 115V is delivered to pump coil.
	<ul style="list-style-type: none"> Faulty Pump on a wet rotor pump 	<ul style="list-style-type: none"> Pump impeller may be stuck. Use a flat head screwdriver on face of pump to turn impeller manually Replace Pump
	<ul style="list-style-type: none"> Air in the piping system 	<ul style="list-style-type: none"> Purge all air from the piping system
	<ul style="list-style-type: none"> Internal Fault on DynaMax HS Controller 	<ul style="list-style-type: none"> Replace DynaMax HS Controller
Relief Valve	<ul style="list-style-type: none"> System pressure exceeds relief valve setting 	<ul style="list-style-type: none"> Replace the standard relief valve with a higher rated valve up to the maximum pressure of the heat exchanger. Improperly sized expansion tank.
Flow Proving Device/ LWCO	<ul style="list-style-type: none"> Flow Proving Device/ LWCO contacts are open 	<ul style="list-style-type: none"> Verify LED's on current sensing transformer during a heat demand (wall hung) Check flow switch paddle (floor mount) Verify for closed valves or obstructions in boiler piping Verify that all air has been purged from the system Verify that wiring is correct
Flame Failure (Pressing the manual OK button on the DynaMax HS Control Panel to restart the ignition sequence)	<ul style="list-style-type: none"> The boiler has failed to ignite the burner after 3 consecutive attempts 	<ul style="list-style-type: none"> Verify that all air has been purged from gas line Inspect spark electrode and related wiring for damage and connection errors Verify that the ignition fan speed is set to 3000 RPM through fan diagnostics screen. Verify that boiler is properly grounded Verify incoming gas supply pressure and that it coincides with Table 9. Verify that the vent/ air inlet piping (if equipped) are correctly installed and obstructions are not present. Check wiring from DynaMax HS Controller, Gas Valve Transformer and Gas Valve Relay. If a signal cannot be detected, the DynaMax HS Controller needs to be replaced If 24 VAC is present, check the outlet of the valve to ensure that gas is flowing. With a manometer connected to the outlet pressure tap of the gas valve a negative pressure should be present during pre-purge. When the valve is energized a change in pressure should occur, if no change is detected the gas valve has failed to open or it is passing insufficient amount of gas. If this is an initial startup increase the low fire gas setting by ¼ turn clockwise. Inspect flame sensor and associated wiring. Replace if necessary Inspect the burner. Refer to Burner Maintenance in section 9.7 Replace the DynaMax HS Controller

SYMPTOM	FAILURE MODE	ANALYSIS
<p>Flame Disappears During a Run Cycle (Pressing the manual OK button on the DynaMax HS Control Panel to restart the ignition sequence)</p>	<ul style="list-style-type: none"> • The DynaMax HS boiler was running and flame signal suddenly disappeared. • Lockout: 106, 107, 108, 109 • Alert 149, 150 	<ul style="list-style-type: none"> • Verify that minimum fan speed is greater than 2500 RPM • Verify that all air has been purged from gas line • Inspect spark electrode and related wiring for damage and connection errors. • Verify that boiler is properly grounded • Verify incoming gas supply pressure and that it coincides with Table 9. • Verify that the gas line connections to the boiler are adequate • Verify that the vent/ air inlet piping (if equipped) are correctly installed and obstructions are not present • Verify that 24 VAC is being supplied to the gas valve during ignition. If a signal cannot be detected, the transformer needs to be replaced • Inspect flame sensor and associated wiring. Replace if necessary • Inspect the burner. Refer to Burner Maintenance in section 9.7 • Replace the DynaMax HS Controller if necessary
<p>Noisy Operation</p>	<ul style="list-style-type: none"> • Supply Gas Issue 	<ul style="list-style-type: none"> • Refer to Part 3 Gas Connection in this manual. • Natural Gas Pressure should read between 3" w.c. and 14" w.c. • L.P. Gas Pressure should be at 11" w.c.
	<ul style="list-style-type: none"> • Air/Gas Mixture Issue 	<ul style="list-style-type: none"> • Refer to Gas Valve Adjustment Procedure in section 10.2 of this manual for the proper combustion setting.
	<ul style="list-style-type: none"> • Air Inlet and/or Vent configuration 	<ul style="list-style-type: none"> • Refer to Part 2 Air Inlet and Venting
	<ul style="list-style-type: none"> • Dirty/ Damaged burner 	<ul style="list-style-type: none"> • Refer to Burner Maintenance in section 9.7 of this manual for the burner removal and inspection procedure. Clean or replace the burner, if required.
	<ul style="list-style-type: none"> • Air in the piping system 	<ul style="list-style-type: none"> • Purge all air from the piping system
	<ul style="list-style-type: none"> • Incorrect igniter gap 	<ul style="list-style-type: none"> • Check that spark gap is 9/64"
<p>Auto Reset High Limit Trips</p>	<ul style="list-style-type: none"> • The outlet temperature has exceeded the setpoint temperature specified. • Alert 63, 67, 79, 137, 276-281 • ILK off 	<ul style="list-style-type: none"> • Verify that the system is full of water and that all air has been properly purged from the system. • Verify that the boiler is piped properly. Refer to Piping Diagrams in Section 13 of this manual. • Verify that 120VAC is being supplied to the boiler pump on a call for heat. If voltage cannot be detected check wiring. • Verify that the pump is circulating when 120VAC is detected. If not, pump impeller may be stuck. Use a flat head screwdriver on face of pump to turn impeller manually, if possible. • If 120VAC is present during a call for heat, but the pump still does not circulate, replace the pump. • Replace the main DynaMax HS Controller if necessary
<p>Manual Reset High Limit Trips</p>	<ul style="list-style-type: none"> • Manual Reset Safety High Limit tripped, outlet temperature in excess of 210°F • Alert 63, 67, 79, 137, 276-281 • ILK off 	<ul style="list-style-type: none"> • Verify that the capillary tube is broken. If this is the case, replace Manual Reset High Limit • Verify that the system is full of water and that all air has been properly purged from the system. • Verify that the boiler is piped properly. Refer to Piping Diagrams in Section 13 of this manual. • Verify that 120 VAC is being supplied to the boiler pump on a call for heat. If voltage cannot be detected check wiring. • Verify that the pump is circulating when 120 VAC is supplied. If so, pump impeller may be stuck. Use a flat head screwdriver on face of pump to turn impeller manually. • If 120 VAC is present during a call for heat, but the pump still does not circulate, replace pump.

SYMPTOM	FAILURE MODE	ANALYSIS
Temperature Overshoot	<ul style="list-style-type: none"> Stack temperature has exceeded the limit set on the boiler. Alert 125, 353 	<ul style="list-style-type: none"> PVC: Reduce desired setpoint to less than 140°F. Measure the resistance of the flue sensor at room temperature, it should be approximately 10kΩ. PVC: 149°F CPVC: 194°F PPE: 230°F Stainless Steel, AL29-4C: 250°F
	<ul style="list-style-type: none"> Outlet temperature has exceeded limit temperature Alert 63, 67, 79, 137, 276-281 ILK OFF 	<ul style="list-style-type: none"> Verify that the system is full of water and that all air has been properly purged from the system Verify that the boiler is piped properly. Verify that adequate power is supplied to pump on a call for heat. If voltage cannot be detected check wiring Verify pump is circulating when power is supplied. If so, pump impeller may be stuck. If power is present during a call for heat, but the pump still does not circulate, replace the pump. Replace the DynaMax Controller, if necessary.
Sensor Not Connected	<ul style="list-style-type: none"> Inlet sensor, Alert: 91 Outlet sensor, Alert: 92 DHW sensor, Alert: 93 Flue sensor, Alert: 95 Outdoor sensor, Alert: 96 	<ul style="list-style-type: none"> Verify that the sensors are connected Verify that they are wired correctly. Measure the resistance of the sensors, 10kΩ sensors. Replace the sensor if necessary
Fan Not Turning	<ul style="list-style-type: none"> Fan refuses to rotate Alert 122, 123, 128, 129, 130,131, 132 	<ul style="list-style-type: none"> Check fan power wires Fan signal wires are interchanged Minimum fan speed must be greater than 1500 RPM
Blocked Flue Switch	<ul style="list-style-type: none"> Check gas pressure switches, if equipped Alert 63, 67, 79, 137, 276-281 ILK OFF 	<ul style="list-style-type: none"> Blocked flue switch wire(s) is/are loose Blocked flue switch is set too light if it trips at full fan speed, reduce sensitivity by turning screw 1 turn clockwise.
Flame Detection is out of Sync	<ul style="list-style-type: none"> Flame detection is present when no visible signs of a flame exist Lockout 105, 158 	<ul style="list-style-type: none"> Verify supply voltage for proper polarity. Check external wiring for voltage feedback Check internal wiring for proper connections Check the flame sensor and verify that it is clean Replace DynaMax HS Controller
Blank Display Screen	<ul style="list-style-type: none"> Blank display screen 	<ul style="list-style-type: none"> Check S4 switch position on ignition module. Switch is pushed towards J5 connector Check that display is connected to the standalone connector on the back of the display Replace fuse with factory 3.15A fuse. DO NOT use alternates as it may damage the DynaMax HS Controller
Internal Fault	<ul style="list-style-type: none"> Alert 3-9, 20-31 Lockout 10-18, 32-46, 58-60 ,97-99, 143-148 	<ul style="list-style-type: none"> Reset SOLA If fault persists, replace SOLA

Manual Reset Codes*

#	Description
0	None
1-31	Internal hardware error
47	Flame rod to ground leakage
49	24VAC low/high
64	Fan speed not proved, ignition failure
67	Blocked flue condition
79	Heater Outlet high limit tripped
82	Stack limit tripped (PVC: 149°F, CPVC: 194°F, PPE: 230°F, SS, AL29-4C: 250°F)
91	Inlet sensor fault
92	Outlet sensor fault
93	DHW sensor fault
95	Stack sensor fault
96	Outdoor sensor fault
105	Flame detected out of sequence
106	Flame lost in Main Flame Establishing Period (MFEP)
107	Flame lost early in run
108	Flame lost in run
109	Ignition failed
112	Pilot test flame timeout
113	Flame circuit timeout
149	Flame detected

* To eliminate the hard lockout error,

- 1) Press the **OK** button to clear the error on screen

Automatic Reset Codes

#	Description
0	None
29	Burner switch turned OFF
30	Burner switch turned ON
47	Flame rod to ground leakage
49	Abnormal 24Vac voltage
50	Modulation Fault
61	Anti-short Cycle
62	Fan speed not proved
67	Interlock Off, safety circuit is open
69	Pilot test hold
78	Demand lost in run
79	Outlet high limit tripped (internal limit)
81	Delta-T limit exceeded (30°F)
91	Inlet sensor fault
92	Outlet sensor fault
93	DHW sensor fault
95	Stack sensor fault
96	Outdoor sensor fault
97-99	Internal Fault
128	Fan speed failed during prepurge
129	Fan speed failed during preignition
130	Fan speed failed during ignition
131	Fan movement detected during standby
132	Fan speed failed during run
137	Interlock failed to close, safety circuit is open
110	Ignition failure occurred
111	Flame current below threshold (0.8Vdc)
149	Flame detected
150, 291	Flame not detected
301 - 309	Interlock Off, safety circuit is open
460	Interlock off during burn, safety circuit is open
614	Lead boiler was rotated based on measured run time

Ignition Failed displayed on screen

Hold 109: Ignition failed

An ignition error occurs when 3 consecutive attempts at lighting the burner have failed. This is a manual reset error where the technician must press OK to clear the error.

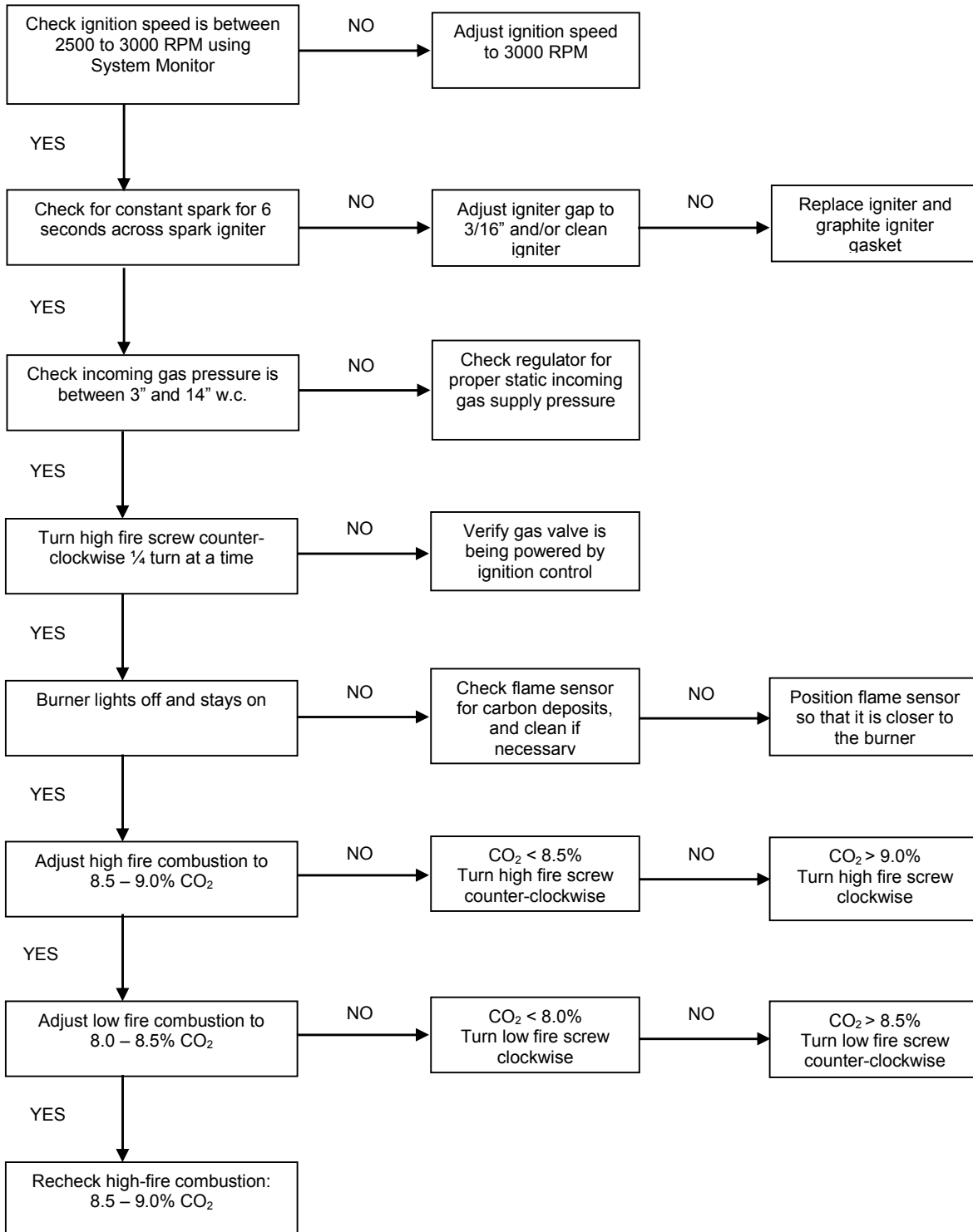

Hold 63: LCI OFF (Flow Switch, LWCO, Blocked Flue Switch)
Hold 67: ILK OFF (Gas Pressure Switch, High Limit)
Alert 303: Abnormal Recycle: ILK off during drive to Purge
Alert 304: Abnormal Recycle: ILK off during Measured purge time
Alert 305: Abnormal Recycle: ILK off during Drive to Pre-ignition
Alert 306, 307: Abnormal Recycle: ILK off during Pre-ignition
Alert 308: Abnormal Recycle: ILK off during Main Flame
Alert 309: Abnormal Recycle: ILK off during Ignition Period

This error can indicate a blocked flue or blocked intake condition, low gas pressure switch tripped (optional) or high gas pressure switch tripped (optional). To identify the safety that is open set the multimeter to Vac and measure the voltage from one contact to ground. The contacts produce a 24Vac when the circuit is closed.

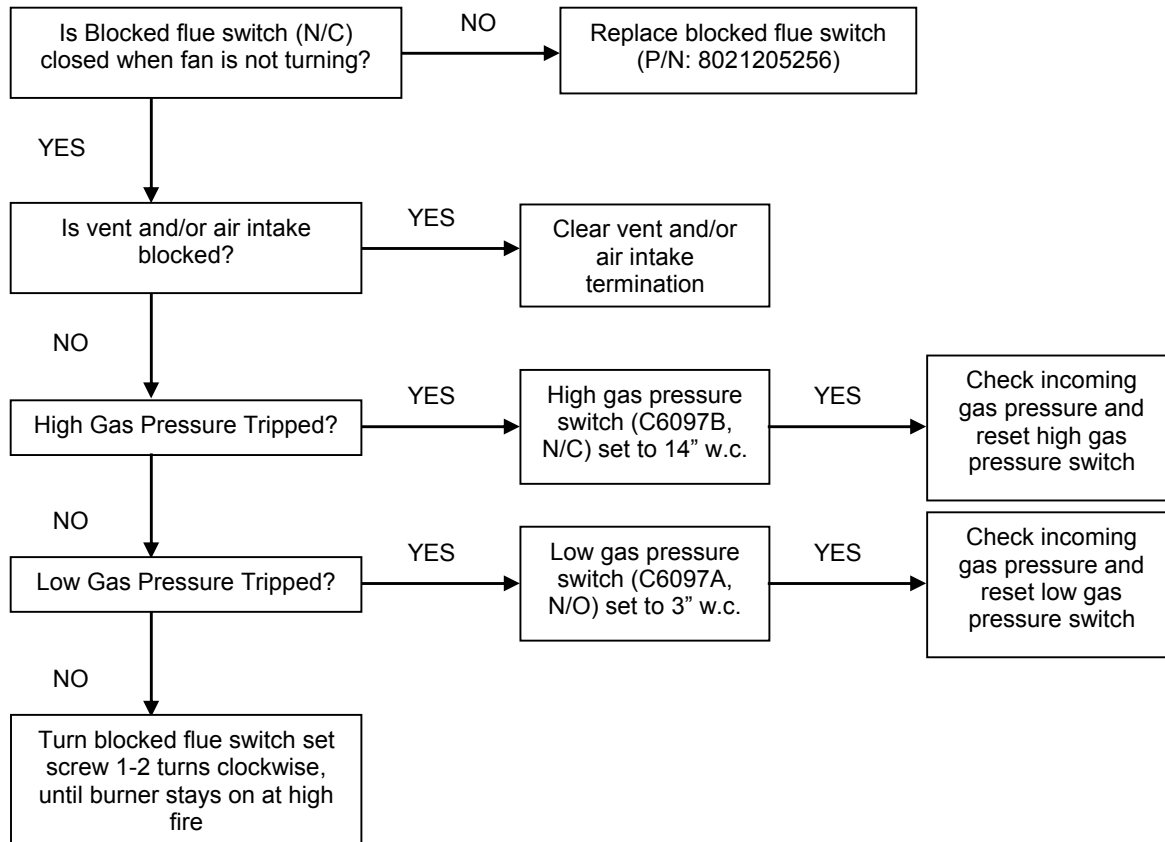

- Hold 63: LCI OFF (Flow Switch, LWCO, Blocked Flue Switch)**
- Hold 67: ILK OFF (Gas Pressure Switch, High Limit)**
- Alert 303: Abnormal Recycle: ILK off during drive to Purge**
- Alert 304: Abnormal Recycle: ILK off during Measured purge time**
- Alert 305: Abnormal Recycle: ILK off during Drive to Pre-ignition**
- Alert 306, 307: Abnormal Recycle: ILK off during Pre-ignition**
- Alert 308: Abnormal Recycle: ILK off during Main Flame**
- Alert 309: Abnormal Recycle: ILK off during Ignition Period**

The flow switch is not closed or the low water cutoff (LWCO, optional) was tripped. This is an automatic reset error and as soon as flow is proven this error resolves itself. To identify the safety that is open set the multimeter to Vac and measure the voltage from one contact to ground. The contacts produce a 24Vac when the circuit is closed.

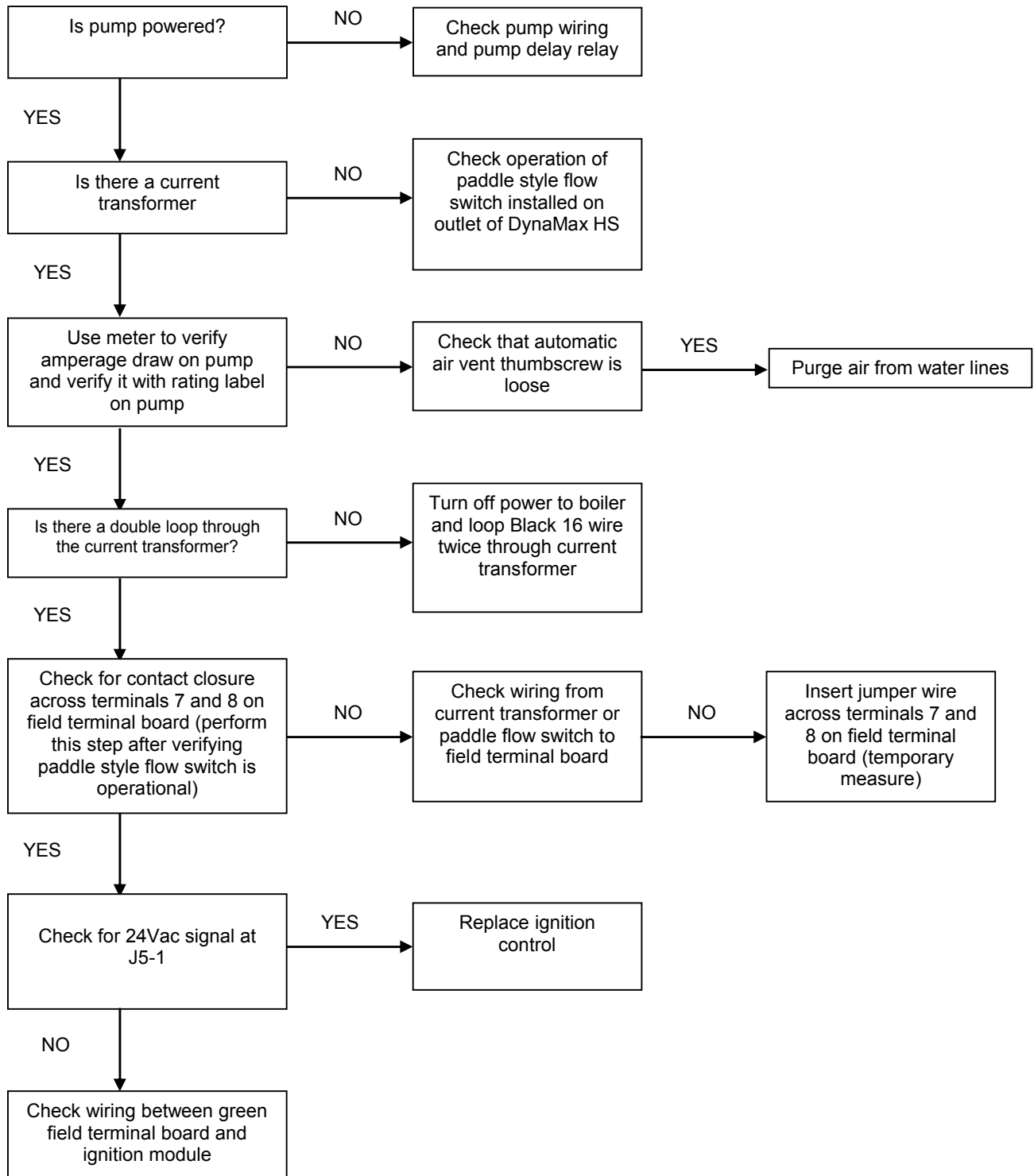

Stack limit exceeded displayed on screen

Alert 125: Modulation was limited due to stack limit

Alert 353: Abnormal recycle: stack limit

A flue gas error occurs when the stack temperature has exceeded the maximum limit allowed by the vent material. This is an automatic reset error, when the stack temperature drops 20°F below the limit allowed the boiler is allowed to restart and an ignition attempt is made if the call for heat is not yet satisfied. In the event that a setpoint greater than 150°F is selected and PVC venting is used the setpoint must be reduced to below 150°F to avoid nuisance flame failures. If a setpoint greater than 150°F is required, venting with CPVC, AL29-4C, 316LL or PPE is strongly advised.

The stack temperature is between 15-30°F above the incoming (return) water temperature to the appliance.

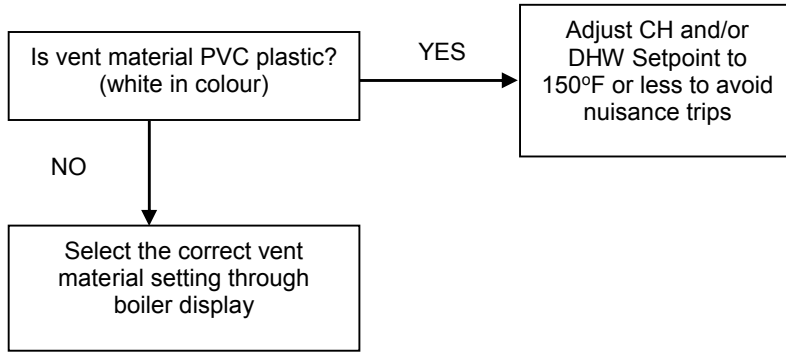

Vent Material	Maximum Flue Temperature [°F]
PVC	149
CPVC	194
PPE	230
AL29-4C	300+, limited only by rating of seals
316L Stainless Steel	300+, limited only by rating of seals

Alert 291: Abnormal Recycle: Flame was not on at end of ignition
Alert 294: Abnormal Recycle: Flame was lost during Run
Alert 324: Abnormal Recycle: Hardware flame bias
Alert 377: Abnormal Recycle: Hardware flame bias delta

This type of failure indicates a flame rectification signal issue through the flame rod.

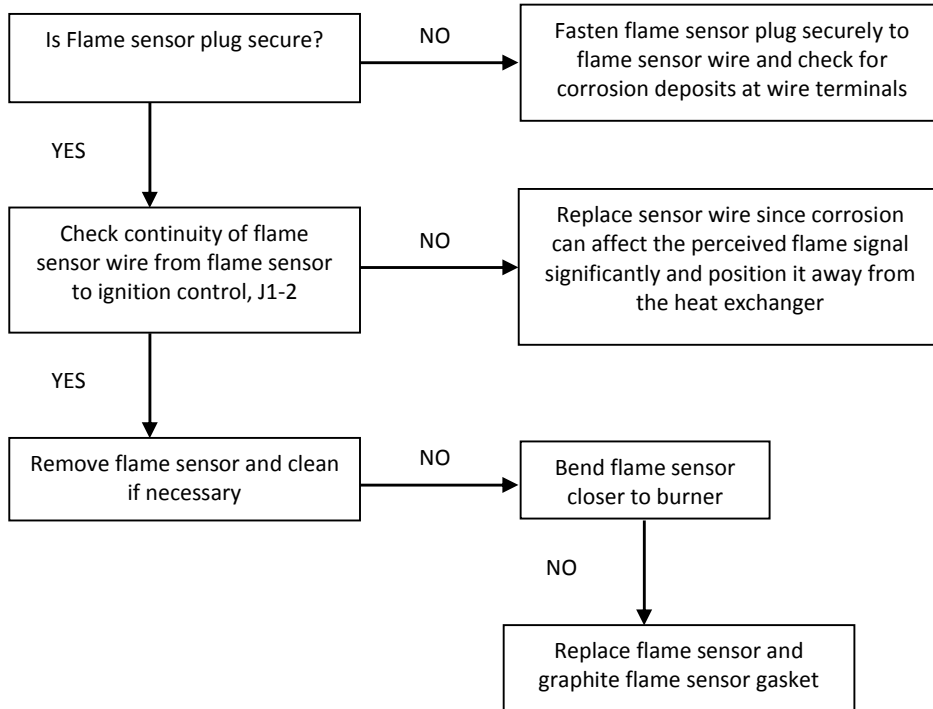

8.1 SETTING THE CORRECT COMBUSTION

- 1) Switch the main power off to the boiler by placing the toggle switch in the 'OFF' position
- 2) Switch the main power on to the boiler and adjust set point so that boiler begins ignition sequence.
- 3) Observe the boiler as it goes through its startup cycle and operates at high fire.
- 4) Insert the combustion measurement probe into the stack when high fire operation is observed. Check to see that fan is running at maximum fan speed using the control panel.
- 5) The combustion values should reside in the range listed in Table 31. If combustion values are not within this range refer to Section 10.2 Gas Valve Adjustment Procedure to correct this issue.

Table 19: Combustion Values

	Natural Gas		Propane	
	CO ₂	CO	CO ₂	CO
Max. Fire	8.5% - 9.0%	<100 PPM	9.5% - 10.0%	<100 PPM
Min. Fire	8.0% - 8.5%	<100 PPM	9.0% - 9.5%	<100 PPM

- 6) When the combustion values are satisfied record these values as Camus® requires these for warranty purposes.
- 7) Remove the combustion measurement device and switch the main power off to the boiler by placing the toggle switch in the 'OFF' position.
- 8) Replace the flue temperature sensor back to its proper location.

8.2 GAS VALVE ADJUSTMENT PROCEDURE

If adjustment of the gas valve is required use the following procedure.

In order to perform adjustments to the gas valve the DynaMax HS must be firing before proceeding.

DM 080 – 250, 260

Figure 56: Venturi & Gas Valve Assembly

Low-fire adjustment screw
(use Torx 40 for adjustment, clockwise increases CO₂)

High-fire adjustment screw
(use slotted screwdriver for adjustment, counter-clockwise increases CO₂)

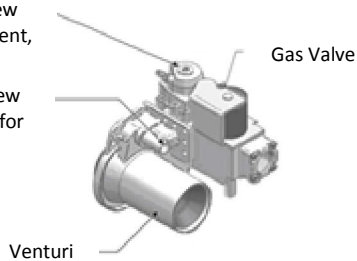

To adjust the high-fire setting

- 1) Press the **i** button
- 2) Select *Test* and press **OK**
- 3) Select *Forced Rate* and press **OK**
- 4) Select *Set High Fire*

Locate the input adjustment screw on the side of the venturi. Turn the screw 1/8 turn in either way for each adjustment to keep track of the adjustments. After adjusting the screw wait a moment for the combustion levels to stabilize before attempting to make any further adjustments. Continue this procedure until combustion levels are satisfied.

	Increase CO ₂	Decrease CO ₂
High Fire Adjustment	Counter-Clock Wise	Clockwise

Select *Stop Test* to return to normal operation or the boiler will return to normal operation after 5 minutes

To adjust the low fire setting

- 1) Press the **i** button
- 2) Select *Test* and press **OK**
- 3) Select *Forced Rate* and press **OK**
- 4) Select *Set Low Fire*

The DynaMax HS should respond immediately and fire at minimum fan speed. This screw is covered with a cap, which can be removed using a Torx 40 screwdriver. When the correct combustion values are achieved replace the screw cap back on to the gas valve.

	Increase CO ₂	Decrease CO ₂
Low Fire Adjustment	Clockwise	Counter-Clock Wise

Select *Stop Test* to return to normal operation or the boiler will return to normal operation after 5 minutes

Figure 57: DM 299 – 399 Gas Valve

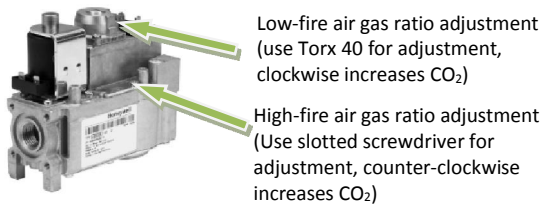

To adjust the high-fire setting

- 1) Press the ⓘ button
- 2) Select *Test* and press **OK**
- 3) Select *Forced Rate* and press **OK**
- 4) Select *Set High Fire*

Locate the high-fire adjustment screw on the top side of the gas valve. The screw can be identified by a red cylinder casing around the screw. Turn the screw 1/8 turn in either way for each adjustment to keep track of the adjustments. After adjusting the screw wait a moment for the combustion levels to stabilize before attempting to make any further adjustments. Continue this procedure until combustion levels are satisfied.

	Increase CO2	Decrease CO2
High Fire Adjustment	 Counter-Clock Wise	 Clockwise

Select *Stop Test* to return to normal operation or the boiler will return to normal operation after 5 minutes

To adjust the low fire setting

- 1) Press the ⓘ button
- 2) Select *Test* and press **OK**
- 3) Select *Forced Rate* and press **OK**
- 4) Select *Set Low Fire*

The DynaMax HS should respond immediately and fire at 1500 RPM. When this is achieved locate the low fire adjustment screw as illustrated in Figure 57. When the correct combustion values are achieved replace the screw cap back on to the gas valve.

	Increase CO2	Decrease CO2
Low Fire Adjustment	 Clockwise	 Counter-Clock Wise

Select *Stop Test* to return to normal operation or the boiler will return to normal operation after 5 minutes

Figure 58: DM 500 - 800 Gas Valve

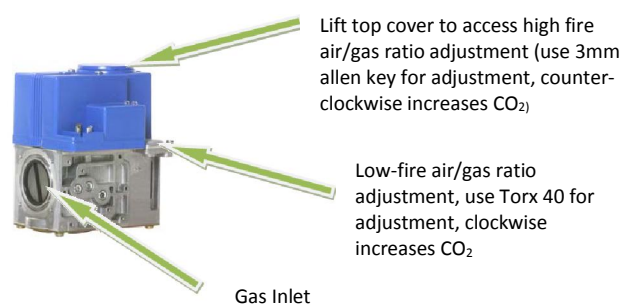

To adjust the high-fire setting

- 1) Press the ⓘ button
- 2) Select *Test* and press **OK**
- 3) Select *Forced Rate* and press **OK**
- 4) Select *Set High Fire*

Locate the input adjustment screw on the top side of the gas valve. Turn the screw 1/8 turn in either way for each adjustment to keep track of the adjustments. After adjusting the screw wait a moment for the combustion levels to stabilize before attempting to make any further adjustments. Continue this procedure until combustion levels are satisfied.

	Increase CO2	Decrease CO2
High Fire Adjustment	 Counter-Clock Wise	 Clockwise

Select *Stop Test* to return to normal operation or the boiler will return to normal operation after 5 minutes

To adjust the low fire setting

- 1) Press the ⓘ button
- 2) Select *Test* and press **OK**
- 3) Select *Forced Rate* and press **OK**
- 4) Select *Set Low Fire*

The DynaMax HS should respond immediately and fire at 1500 RPM. When this is achieved locate the low fire adjustment screw as illustrated in Figure 58. When the correct combustion values are achieved replace the screw cap back on to the gas valve.

	Increase CO2	Decrease CO2
Low Fire Adjustment	 Clockwise	 Counter-Clock Wise

Select *Stop Test* to return to normal operation or the boiler will return to normal operation after 5 minutes

PART 9 MAINTENANCE

CAUTION

It is important that all gas appliances be serviced by a qualified technician trained by Camus® Hydronics. It is in your own interest and that of safety to ensure that all local codes, and all the "NOTES" and "WARNINGS" in this manual are complied with. To service or adjust this appliance, it is imperative that the serviceman utilize a combustion analyzer to read CO₂ and CO according to Camus® Hydronics recommendations.

Listed below are items that must be checked to ensure safe reliable operations. Verify proper operation after servicing.

9.1 EXAMINE THE VENTING SYSTEM

Examine the venting system at least once a year. Check more often in the first year to determine inspection interval. Check all joints and pipe connections for tightness, corrosion or deterioration. Flush the condensate drain hose with water to clean. Clean screens in the venting air inlet system as required. Have the entire system, including the venting system, periodically inspected by a qualified service agency.

9.2 VISUALLY CHECK MAIN BURNER FLAMES

At each start up after long shutdown periods or at least every six months. A burner view port is located on the combustion chamber front door.

CAUTION

The area around the burner view port is hot and direct contact could result in burns

Figure 31: Normal Burner Flame Profile (short dense and blue)

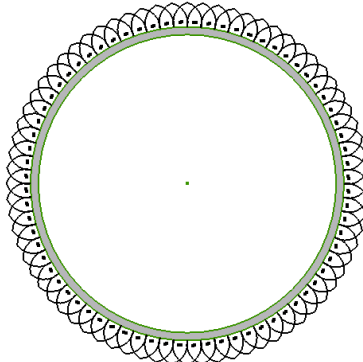

- **Normal Flame:** A normal flame at 100% of burner input is blue, with a well-defined flame and no flame lifting.
- **Yellow Tip:** Yellow tipping can be caused by blockage or partial obstruction of air flow to the burner.
- **Yellow Flames:** Yellow flames can be caused by blockage of primary air flow to the burner or excessive gas input. This condition **MUST** be corrected immediately.

If improper flame is observed, examine the venting system; ensure proper gas supply and adequate supply of combustion and ventilation air.

9.3 CLEANING BOILER HEAT EXCHANGER

Figure 32: Heat Exchanger & Burner Assembly

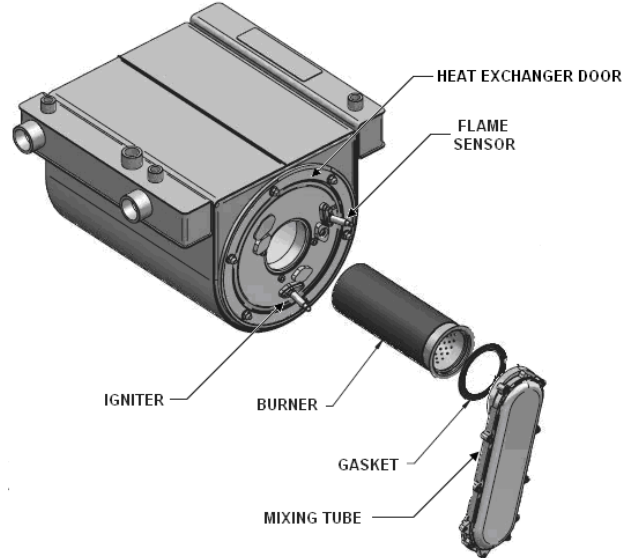

- 1) Shut down boiler:
 - a) Turn the main power off to the boiler
 - b) Shut off gas supply at the main manual valve in the gas piping of the main appliance
 - c) DO NOT drain the boiler unless it will be exposed to freezing temperatures. If using antifreeze fluid in the heat exchanger, **DO NOT** drain.
- 2) Allow time for the boiler to cool to room temperature if it has been firing.
- 3) **Wall Hung:** Remove both the stainless steel upper jacket and the lower sheetmetal jacket.
Floor Mount: Remove front stainless steel panel.
- 4) Remove igniter and flame sensor electrodes. If necessary, clean with steel wool. **DO NOT** use sandpaper.
- 5) Remove the fan/ mixing tube assembly from the heat exchanger door.
- 6) Remove burner.
- 7) Examine burner and clean if required as per 9.7.1.
- 8) Examine heat exchanger surfaces to determine if cleaning is required. If cleaning is required remove the (6) nuts fastening the heat exchanger flange from the heat exchanger.
- 9) Disconnect the condensate hose from the heat exchanger and connect a 5/8" diameter hose (field supplied) from the bottom of the heat exchanger to a drain
- 10) Use water proof material to carefully cover the refractory at the rear of the combustion chamber of the heat exchanger.
- 11) Use a vacuum cleaner to remove any debris that has collected on the heat exchanger surfaces. **DO NOT** use any type of solvent.

- 12) Brush the heat exchanger with a nylon bristle brush. **DO NOT** use a metal brush. Re-vacuum the heat exchanger.
- 13) Finish cleaning by wiping down the boiler heating surfaces with a clean, damp cloth.
- 14) Rinse out any additional debris with a low pressure water supply. Start rinsing from the rear of the heat exchanger and slowly working your way towards the front of the heat exchanger.
- 15) Remove the water proof material after cleaning is complete.
- 16) Re-install the heat exchanger door by evenly torquing down the (6) nuts to 3 ft-lbs, burner, igniter and flame sensor, and fan/ mixing tube assembly. Fasten the nuts back to the heat exchanger assembly.
- 17) Re-connect the fan assembly to the boiler mixing tube.
- 18) Re-connect the condensate hose to the heat exchanger.

NOTE

All gaskets on disassembled components must be replaced with new gaskets/sealant on re-assembly, if required. Gasket kits are available from the factory

CAUTION

When the vent system is disconnected for any reason it must be reassembled and resealed according to vent manufacturer's instruction

9.4 CONDENSATE TREATMENT

Condensate occurs when the products of combustion are cooled below their dew point in the heat transfer process. The liquid condensate formed from this high efficiency heat transfer process is mildly acidic.

- The condensate will typically have a pH ranging from 4.0 to 5.0 as it is discharged from the condensate drain of the appliance.
- The condensate collection box inside each DynaMax HS where the condensate is collected is constructed of a non-corrosive material.
- All materials external to the appliance in contact with the condensate must be corrosion resistant.
- Condensate must be able to flow freely from the appliance. All condensate flow is accomplished by gravity requiring a minimum downward slope of 1/4" per foot (21mm/m) to ensure proper flow to a suitable drain.
- All condensate piping and connections must be easily accessible for routine maintenance and inspection.
- Use solid piping when running condensate line across the floor.
- Check neutralized pH level regularly or as required by local jurisdiction. Replace neutralizer medium as required.

There are several factors affecting amount of condensation created by the appliance, however for rough approximation use.

$$\text{Condensation Volume, US Gallon/Hr} = \text{Input, MBH}/1000 \times 5.0$$

Many jurisdictions will require the acidic condensate to be neutralized before it can be placed in a drain system.

- A neutralizer, calcium carbonate, to control the pH of the liquid discharged to a drain system is provided with every DynaMax HS boiler.
- As the reservoir fills, it provides an extended residence time to neutralize the condensate.
- Residency time in the neutralizer reservoir allows time for the pH to be raised.
- Prime the neutralizer reservoir with 1 liter of water.

As the condensate migrates through the reservoir in typical applications the pH is controlled to a range of 5.5 to 6.0 before exiting the system. Always check with local codes for specific requirements.

9.5 IGNITER AND FLAME SENSOR ELECTRODES

The direct spark igniter is to be checked at every service interval. Clean the direct spark igniter as required to maintain peak ignition efficiency.

- 1) Turn off main electrical power to the appliance.
- 2) Turn off main manual gas shutoff to the appliance.
- 3) Locate the direct spark igniter and flame sensor.
- 4) Disconnect the power lead to the direct spark igniter and flame sensor
- 5) Loosen and remove the two (2) torx screws that hold the igniter and flame sensor to the heat exchanger flange.
- 6) Pull the igniter horizontally out of the heat exchanger flange. Use care, do not hit or break the igniter leads.
- 7) Remove any debris that has accumulated on the electrodes using steel wool. If the electrodes cannot be cleaned to their original appearance, replacements are needed. Do not use sand-paper since this will contaminate the surface.
- 8) Check that the igniter and flame sensor gaskets are still in good condition (no tears or seams). If the gaskets are in good condition the electrodes can be re-installed back to the heat exchanger flange.
- 9) Check that the igniter gap is 13/64".
- 10) Tighten the mounting screws to no more than 10 in-lb.

9.6 CHECK IGNITER GROUND WIRING

- 1) Inspect boiler ground wire from the heat exchanger flange to ground on boiler. Check boiler ground wire continuity.
- 2) Verify that all wiring is in good condition and is securely anchored.

9.7 BURNER MAINTENANCE

The burner should be removed for inspection and cleaning on an annual basis. An appliance installed in a dust or dirt contaminated environment will require inspection and cleaning on a more frequent schedule. The fan assisted combustion process may force airborne dust and dirt contaminants, contained in the combustion air, into the burner. With sustained operation, non-combustible contaminants may reduce burner port area, reduce burner input or cause non-warrantable damage to the burner. **Never operate this appliance during construction.**

Airborne contaminants such as dust, dirt, concrete dust or dry wall dust can be drawn into the burner with the combustion air and block the burner port area.

9.7.1 Burner Removal and Cleaning

Access to the burner will require the following steps:

- Turn off main electrical power to the appliance.
- Turn off main manual gas shutoff to the appliance
- Remove the front cover.
- Disconnect the gas supply to the fan inlet.
- Disconnect the fan motor power wires at the harness.
- Remove the direct spark igniter and the flame sensor.
- Remove the T-25 screws holding the front burner flange in place to gain access to the burner.
- The burner can now be pulled horizontally out of the heat exchanger cavity.
- Use care to prevent damage to the knitted metal fiber of the burner surface.
- Wash the burner with water, such as a garden hose. Never wipe or brush the surface of the burner.
- For optimal results immerse the burner port area in a solution of dishwashing detergent and hot water. **DO NOT** use chlorine based solvents or cleaning agents on the burner. Allow the burner to remain in the solution for a short period of time to remove, dust, dirt and oil or grease laden contaminants.
- Rinse the burner thoroughly with clean water to remove any residue from the detergent cleaner
- The burner should be air dried after removal from the cleaning solution and rinsing.
- Check all gaskets and replace as necessary. Gaskets affected by heat will not reseal properly and must be replaced.
- Replace the burner in the reverse order that it was removed.

NOTE

When the combustion air fan is removed for any reason, the inlet to the burner must be covered to prevent foreign objects from falling into the burner. Always look inside the burner to check for dents. Do not place a burner back into operation if the inner distribution screen has been dented during the service operation, call the factory for recommendations. Use care when removing and handling the burner, Sharp objects or impact may damage or tear the metal fiber surface rendering the burner unfit for service.

9.8 REMOVAL OF COMBUSTION CHAMBER LINING

The combustion chamber insulation in this appliance contains ceramic fiber material. Ceramic fibers can be converted to cristobalite in very high temperature applications. The International Agency for Research on Cancer (IARC) has concluded, "Crystalline silica in this form of quartz or cristobalite from occupational sources is carcinogenic to humans (Group 1)". Normal operating temperatures in this appliance are below the level to convert ceramic fibers to cristobalite. Abnormal operating conditions would have to be created to convert the ceramic fibers in this appliance to cristobalite.

The ceramic fiber material used in this appliance is an irritant; when handling or replacing the ceramic materials it is advisable that the installer follow these safety guidelines.

- Avoid breathing dust and contact with skin and eyes.
 - Use NIOSH certified dust respirator (N95). This type of respirator is based on the OSHA requirements for cristobalite at the time this documentation was written. Other types of respirators may be needed depending on the job site conditions. Current NIOSH recommendations can be found on the NIOSH website at <http://www.cdc.gov/niosh/homepage.html>. NIOSH approved respirators, manufacturers, and phone numbers are also listed on this website.
 - Wear long-sleeved, loose fitting clothing, gloves, and eye protection
- Apply enough water to the combustion chamber lining to prevent airborne dust.
- Remove the combustion chamber lining from the water heater and place it in a plastic bag for disposal.
- Wash potentially contaminated clothes separately from other clothing. Rinse clothes washer thoroughly.
- **NIOSH stated First Aid**
 - Eye: Irrigate immediately
 - Breathing: Fresh air

9.9 COMBUSTION AND VENTILATION AIR

Check frequently to be sure that the flow of combustion air to the appliance is not obstructed. Unless air is piped directly to the heater combustion air must be provided to the mechanical room with openings sized per the requirements of the current B149 or National Fuel Gas Code. The DynaMax HS is setup to allow outdoor combustion air to be connected directly to the appliance. It is highly recommended that combustion air be connected directly to the appliance. For installations in a common boiler room with atmospheric appliances or if there is the possibility of negative pressure in the boiler room, the air inlet must be piped directly to the DynaMax HS.

9.10 GAS VALVE VOLTAGE

This appliance uses a transformer to supply a 24 volt signal to the Honeywell SOLA. The voltage on the secondary side should be 24 to 28VAC when measured with a voltmeter. A secondary voltage of 21VAC or less supplied to 24VAC components may cause operational problems.

9.11 COMBUSTIBLE MATERIALS

CAUTION

Keep appliance clear from combustible materials; do not store **GASOLINE** and other flammable vapors and liquids in the proximity of the appliance.

9.12 FREEZE PROTECTION FOR INDOOR & OUTDOOR INSTALLATIONS

Installations are not recommended in areas where the danger of freezing exists. Proper freeze protection must be provided for appliances installed outdoors, in unheated mechanical rooms or where temperatures may drop to the freezing point or lower. If freeze protection is not provided for the system, a low ambient temperature alarm is recommended for the mechanical room. Damage to the appliance by freezing is non-warrantable.

- **Location** - Heating boilers, hot water supply boilers or water heaters must be located in a room having a temperature of at least 40°F (5°C).
- **Caution** - A mechanical room operating under a negative pressure may experience a downdraft in the flue of an appliance that is not firing. The cold outside air may be pulled down the flue and causing a frozen heat exchanger. This condition must be corrected to provide adequate freeze protection.
- Freeze protection for the appliance using an indirect coil can be provided by using hydronic system antifreeze. Follow the manufacturer's instructions. **DO NOT** use undiluted or automotive type antifreeze.
- **Shut-down and draining** - If for any reason, the unit is to be shut off in a space where danger of freezing exists, the following precautionary measures must be taken:
 - Shut off gas supply.
 - Shut off water supply.
 - Shut off electrical supply.
 - Drain the main exchanger and the brazed plate heat exchanger, if supplied, completely.
 - Ensure that the pump and connecting piping are fully drained.

9.13 FREEZE PROTECTION FOR A HEATING BOILER SYSTEM (Optional)

- Use only properly diluted inhibited glycol antifreeze designed for hydronic systems. Camus® recommends using a 30/70 mixture of glycol antifreeze to water. **DO NOT** exceed a mixture of 50/50.
- Follow the instructions from the antifreeze manufacturer. Quantity of antifreeze required is based on total system volume including expansion tank volume.
- **Antifreeze is denser than water and changes the viscosity of the system. The addition of antifreeze will decrease heat transfer and increase frictional loss in the boiler and related piping. Where antifreeze has been used, to maintain the temperature rise across the appliance confirm that the recommended GPM for pure water has been increased by 15% and the head loss by 20%.**
- Local codes require a back flow preventer or actual disconnect from city water supply when antifreeze is added to the system.
- Always follow the chemical manufacturer's directions when filling or topping-up the system with water mixed with antifreeze. This will prevent any possible reaction of the water with antifreeze which can create sludge.

PART 10 INSTALLATIONS

WARNING

Before starting the boiler, smell near the floor and around the boiler for any gas odours or any unusual odour. Remove the stainless steel jacket and smell the interior of the boiler. If there is any sign of a gas leak, do not proceed with startup. Repair all the leaks before attempting to start the boiler.

WARNING

Propane boilers ONLY – Your local propane supplier adds an odorant to the propane gas to allow for propane gas leak detection. In some cases, the added odorant can fade and the gas may not give off any noticeable odour. Before startup have the local propane supplier check for the correct odorant level in the gas.

10.1 CHECKING THE INSTALLATION

- Inspect the connections for water, gas and electricity.
- Inlet gas pressure must be a minimum of 3" W.C. for natural gas and 11" W.C. for propane.
- With the boiler off, open the main gas supply valve and vent the trapped air from the piping leading to the boiler. Confirm that all gas connections to the heater are tight and that there are no missing test plugs.

Refer to Section 8.1 Setting the Correct Combustion of the manual for recommendations on setting combustion characteristics

10.2 CHECKING THE CONSTRUCTION

- Check the boiler wiring to see that it agrees with the wiring diagram supplied.
- Confirm that all terminal strips and field connections are identified.
- Confirm that the DynaMax HS Controller control is set in the proper mode. In remote mode an external controller determines the set point and the stage contacts on the DynaMax HS Controller are always closed. Auto reset limits are fixed in all Modes.
- With the boiler running, check for flue gas leaks along the inner cabinet joints and around the flue outlet.
- Repair any leaks prior to proceeding to the next step.
- At the factory, adjustments were made to achieve proper input and acceptable burner performance at full input and at minimum input.

10.3 HEATING BOILER INSTALLATIONS

Before beginning the installation, consult local codes for specific plumbing requirements. The installation should have unions and valves at the inlet and outlet of the appliance so it can be isolated for service. An air separation device must be supplied in the installation piping to eliminate trapped air in the system. Locate a system air vent at the highest point in the system. The system must also have a properly sized expansion tank installed. Typically, an air charged diaphragm-type expansion tank is used. The expansion tank must be installed close to the boiler and on the suction side of the system pump (appliance Inlet) to ensure proper operation. Caution: This appliance should not be operated at less than 12 PSIG cold. Pressure will rise when hot. Expansion tank sizing will determine the pressure when the system is hot. Do not operate the system at less than 18-20 PSIG when hot. Water piping must be supported by suitable hangers or

floor stands, NOT by the appliance. Pipe systems will be subject to considerable expansion and contraction. Pipe supports could allow the pipe to slide resulting in noise transmitted into the system. Padding is recommended. The boiler pressure relief valve must be piped to a suitable floor drain. See Section 4.11.

10.4 INSPECT & RECHARGE CONDENSATE COLLECTION/NEUTRALIZING RESERVOIR

- 1) Before starting the unit inspect the condensate reservoir in the DynaMax HS making sure the collection box is intact.
- 2) Remove screw holding lid on to condensate collection box. Remove lid from the condensate collection box
- 3) Examine neutralizer medium and refill as necessary with fresh medium
- 4) Fill with fresh water until the water begins to flow out of drain
- 5) Re-install the lid and hold-down screw on the condensate collection box.

WARNING

The condensate collection box must be filled with water to prevent flue gas emissions from escaping during boiler operation.

CAUTION

- 1) A leak in a boiler "System" will cause the fill system to introduce fresh water constantly, which may cause the tubes to accumulate a line/scale build up. Lime/scale buildup. This will be a **NON-WARRANTABLE FAILURE**.
- 2) If boiler pumps are not operated when treated water is introduced, a corrosion cell may be created in the boilers leading to a failure which is not covered by warranty.
- 3) Target water quality of treated water to be stable and neutral with regards to corrosive/scaling properties. Damage to or failure of the heat exchanger as a result of scaling or corrosive water quality is not covered by warranty.

10.5 WATER CONNECTIONS

System pipe size must be in accordance with Table 10 (depending on model) and, between supply and return lines, must not exceed 50 feet of equivalent length. Connection sizes at the heater are given in Tables 3 & 5. Any reduction in recommended pipe size may decrease flow resulting in high temperature rise across the heat exchanger, boiler noise, flashing to steam and non-warrantable heat exchanger damage.

10.6 PIPING LENGTHS

The appliance circulator provides the water flow from the primary boiler piping, through the boiler and back to the primary system. Pipe diameter and length are critical to ensure proper flow through the boiler.

The secondary loop piping to and from the appliance must have a fully ported ball valve installed in both the supply and return side piping and will be used for isolation only. The ball valves must be the same diameter as the installed piping. If flow control is required, other means of flow control such as globe valve or flow setter should be used.

10.7 SUMMARY

a) Typical Boiler Installations

General Plumbing Rules

- 1) Check all local codes.
- 2) For serviceability, always install unions.
- 3) Always pipe pressure relief valve to an open drain.
- 4) Locate system air vents at highest points of system.
- 5) Expansion tank must be installed near the boiler and on the suction side of the system pump.
- 6) Support all water piping.
- 7) Place drip pan underneath boiler. (if required)

b) Placing the Boiler in Operation

Pre-Start Check List

- 1) Review the location of the boiler, clearances from combustible surfaces and available service clearances.
- 2) Review Part 2 Venting. Ensure that all vent components are fabricated from the correct category of materials with adequate clearance from combustibles. Review the vent termination point for proper location and clearances.
- 3) If a separate combustion air pipe is used, ensure that it is properly sized, sealed and terminated.
- 4) Review the water piping from the boiler to the system. The boiler must be installed in a primary/ secondary piping system. Review the diameter and equivalent length of the installed piping to and from the boiler to ensure proper flow.
- 5) Ensure that a properly sized system pump is installed with an expansion tank.
- 6) Check system pressure. Ensure a minimum of 18-20 PSIG with the system hot and not more than 90% of the rated pressure of the relief valve.
- 7) Review the installed gas piping from the meter to the boiler. Ensure that the gas pipe, meter and any regulators are adequately sized.
- 8) Review the field wiring and electrical service for the boiler controls. Ensure that the electrical service(s) is adequately sized.
- 9) Fill the condensate collector with fresh water until water begins to pour out the drain.
- 10) Ensure that the boiler condensate drain and all vent system condensate drains are properly routed to an acceptable floor drain.

Boiler Set-Up

- 1) Ensure that the boiler and piping system are full of water. Bleed all air from the pump housing and secondary loop.
- 2) Check system for any water leaks.
- 3) Check system for installation of glycol or water treatment where required. Where glycol has been used to maintain the temperature rise across the appliance confirm that the recommended flow for pure water has been increased by 15% and the head loss by 20% while maintaining a 30-35°F rise across the heat exchanger.

Boiler Operational Checks

- 1) Turn the boiler main power switch to the "ON" position.
- 2) Verify operation of the text display on the front panel.
- 3) Program the adjustable points.
- 4) Push the reset button if a manual reset error is displayed.
- 5) Install a manometer on the gas supply to the boiler and verify minimum gas supply pressure as the burner fires at 100% of rated input.
- 6) Verify operation of safeties as necessary (low water cut-off, high limit, gas pressure, etc.).

Boiler Operation

- 1) Appliance should begin the start-up process for the sequence of operation.
- 2) The boiler will fire at approximately 50% of rated input on initial start-up and adjust input as required to meet system demand.
- 3) Based on system demand, the appliance will modulate accordingly.
- 4) As system demand is satisfied, the burner will fire at minimum fire for the given demand and the boiler will cycle off when the demand ceases or is interrupted. When this occurs the combustion air fan will decelerate at a pre-programmed rate before the appliance shuts down.

10.8 DOMESTIC HOT WATER WITH STORAGE TANK

Hot water heaters are designed for installation with a storage tank. The piping between the tank and heater and the control of water velocity, as explained below, are important for correct operation of your hot water heater.

10.9 DOMESTIC HOT WATER WITH PLATE HEAT EXCHANGER

The piping between the plate heat exchanger in the DynaMax HS boiler and to an outlet tap is important for correct operation of the plate heat exchanger. The following procedure should be followed for setting the domestic hot water tuning valve:

- 1) There is a temperature tuning valve inside the DynaMax HS jacket on the domestic hot water outlet from plate exchanger. This valve can be set for field conditions.

- 2) First identify the highest domestic hot water load. For example, in some cases it may be the bath tub and in some cases it may be the clothes washer.
- 3) Allow the DynaMax HS to fire up and reach full fire under maximum hot water load demand conditions.
- 4) Observe the outlet water temperature and close the tuning valve gradually as outlet temperature starts to drop. Allow the system to reach equilibrium between adjustments to the tuning valve.
- 5) Once the tuning valve is properly set, outlet temperatures will never drop below desired minimum temperature.
- 6) Seal stem of tuning valve with silicone to prevent unauthorized tampering.

10.10 TEMPERATURE RISE AT FULL FIRING RATE

- 1) The pump must run continuously when the burner is firing.
- 2) With the pump running and the burner in the off cycle, the inlet temperature and outlet temperature readings on the DynaMax HS Control Panel should read approximately the same temperatures.
- 3) Turn the appliance on and allow time for the temperature to stabilize. Check the temperature rise when the burner is firing at 100% of rated input.
- 4) Compare the temperature rise on the Control Panel with the required temperature rise at the required flow rate on Tables 20 and 21.
- 5) Should adjustment be needed, proceed as follows:

If the temperature rise is too high, the water velocity is too low. Adjust as follows:

- 1) Check for flow restrictions. Check for debris in strainers
- 2) Check diameter and equivalent length of the piping between the storage tank and hot water heater.
- 3) Be sure the pipes between the hot water heater and storage tank are not more than a total of 50 equivalent feet between supply and return lines. If maximum equivalent length for the specified pipe diameter is exceeded, larger diameter pipe may have to be installed to achieve correct flow and temperature rise.
- 4) Be sure all valves are open between the hot water heater and the storage tank. Ensure that all ball valves are fully ported.
- 5) Check the pump to be sure it is running properly and that the pump motor is running in the proper direction.
- 6) Common manifold piping for multiple unit installations will require larger minimum pipe sizes and tank circulating tapping to ensure proper flow.

The required temperature rise and the recommended pump size are based on the heating of potable water with normal hardness. For DHW applications with other than normal water hardness choose a pump for the local water hardness conditions. Alternately soften the water to normal hardness level. Damage to the heat exchanger as a result of scaling or corrosive water conditions is non-warrantable.

Table 20: Temperature Rise across Heat Exchanger (Hydronic Heating)

MODEL [BTU/hr]	TEMPERATURE RISE ACROSS HEAT EXCHANGER			
	30°F (16.7°C)		35°F (19.4°F)	
	USGPM	ΔP-Ft.	USGPM	ΔP-Ft.
80,000	5.0	8.2	4.3	6.2
100,000	6.3	12.3	5.4	9.4
150,000	9.5	10.4	8.1	7.8
199,000	12.6	7.2	10.8	5.8
250,000	15.8	11.5	13.5	8.7
299,000	18.9	9.3	16.2	7.0
399,000	25.2	8.4	21.6	6.3
500,000	31.5	9.2	27.0	6.9
600,000	38.8	17.5	32.0	11.8
700,000	45.3	18.2	40.0	14.4
800,000	51.8	23.5	43.0	16.0

Table 21: Temperature Rise across Heat Exchanger (DHW)

MODEL [BTU/hr]	TEMPERATURE RISE ACROSS HEAT EXCHANGER	
	20°F (11.1°C)	
	USGPM	ΔP-Ft.
80,000	7.5	11.5
100,000	9.4	26.9
150,000	14.0	27.8
199,000	19.2	25.9
250,000	23.5	28.3
299,000	28.8	25.8
399,000	38.4	23.9
500,000	48.6	29.4
600,000	57.6	34.2
700,000	70.4	40.0
800,000	77.6	43.2

CAUTION
Temperature rise cannot be adjusted when the burner is firing at less than 100% of input rate.
CAUTION
Adequate care MUST be taken to prevent potential scald injury when storing water at 140°F (60°C) and hotter.

WARNING
Should overheating occur or the gas supply fail to shut off, do not turn off or disconnect the electrical supply to the pump, instead, shut off the gas supply at a location external to the appliance

10.11 LEAD LAG SETUP

The following components are needed for a Lead Lag setup

- 1) 10kΩ System Sensor

Turn off all the boilers before beginning the setup process.

To setup the DynaMax HS lead lag system follow the instructions:

System Sensor

Insert the supplied 10kΩ system sensor into the building loop. The wires coming out of the system sensor should be connected to terminal #9 and #10 of the terminal board.

NOTE

The use of a system sensor is required in lead lag operation.

- 1) When variable speed main circulators **ARE NOT** used the system sensor is to be placed into the return system piping.
- 2) When variable speed main circulators are used the system sensor is to be placed into the supply system piping.

All SOLA controllers are programmed with a default address of 1. The address of the slave controllers in the system must have a unique address (1..8).

Sequence of Operation:

When a boiler is set as Lead Lag Master = Enabled and Modbus address = 1, the controller of this boiler will drive the lead lag operation.

The outdoor temperature sensor connected to the slave boiler 2 (ie. B-2) will be the outdoor sensor for the lead lag system

- The system temperature sensor connected to boiler 1 in terminals labeled “Outdoor System Sensor” on the terminal board will be the control sensor for lead lag operation.
- The start/stop signal connected to boiler 1 at terminals labeled “Remote Operator” will be the heat demand input for lead lag operation.

When demand for heat is present the lead boiler will start and uses the lead lag parameters for boiler modulation. After a period of “Interstage delay” the master boiler compares the lead lag temperature with the lead lag set point and will check if:

- 1) **An additional boiler is needed**
Lead temp < Lead lag setpoint – Add stage Error threshold
- 2) **Number of boilers remain the same**
Lead lag temp > Lead lag setpoint – Add stage Error threshold **AND**
Lead lag temp < Lead lag setpoint + Drop stage Error threshold
- 3) **A boiler should stop**
Lead lag temp > Lead lag setpoint + Drop stage Error threshold
- 4) **All boilers off**
Lead lag temp > Lead lag setpoint + off hysteresis

If the lead lag master system is interrupted the remaining boilers will operate as standalone boilers based on the Central Heat or DHW parameters when set to “Enabled”.

Rotation

Rotation time is configurable based on equalized run time. For a fixed rotation schedule refer to Additional boiler parameters section on page 33 of this manual, parameter #575 & 733.

Interstage Delay

The length of time to wait between requesting a slave boiler to fire and detecting that it has failed to start. (Default: 2 minutes). Access to this parameter is outlined on page 33 of this manual, parameter #722 and 731.

Base Load Rate

When a call for heat is initiated the lead boiler runs at the desired base load rate (Default: 80%) and continues to operate in this fashion based on the above 3 scenarios. If the lead lag temperature is not satisfied a second boiler is fired at they would both operate at 80% fire rate.

Slave State

Slave Status Manager	
Unknown	Table entry is unused or empty
Available	Slave is operational and ready to use
Add Stage	Stage is getting ready to fire
Suspend Stage	Stage was getting ready but is not needed
Disabled	Slave is locked out or disabled
Recovering	Slave is in time delay to verify that it is operational before considered to be available

Wiring the Lead Lag Setup

Use lead lag terminals on the terminal board to wire lead lag appliances

	Master	Slave 2	..	Slave 7
J3, MB2	A	A	..	A
	B	B	..	B

Figure 33: Lead lag Wiring Setup (Left: Master, Right: Slave)

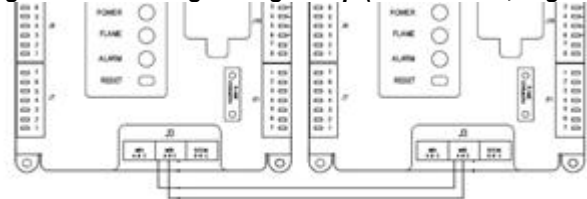

NOTE

Recycle power on all boilers after programming is complete if lag boilers are not discovered automatically

NOTE

CH Setpoint or DHW Setpoint must match Setpoint located in Lead Lag Master Configuration in order for the system to operate correctly.

NOTE

The Local/Remote switch (explained below) must be set in the “Local” position on ALL lag boilers.

10.12 LOCAL/REMOTE SWITCH

The local remote switch mounted on the terminal board is designed to generate a call for heat either relying on an external contact closure (Remote) or enabling the boiler locally (local). When Remote is selected via the SPDT switch the Remote Operator contacts on the terminal board must be closed to initiate a call for heat. When Local is selected via the SPDT switch a constant call for heat is generated which will enable the boiler to proceed to a trial for ignition. When troubleshooting the DynaMax HS it is suggested to switch to Local mode. The Local/Remote switch is independent of the 4-20mA/2-10Vdc signal.

10.13 MODBUS/LOCAL SWITCH

The Modbus/Local Switch mounted on the terminal board is designed to relay the signal to the boiler display (local) or accept an incoming signal from Modbus. When local is selected via the DPDT switch the boiler display presents all necessary boiler information. When Modbus is toggled the boiler display will continue to be illuminated with a message showing "Connection lost". The BMS now overrides the communication link to the boiler.

10.14 APPLIANCE

- * Remove manometers and tighten test port screws.
- * Fill out start up report for each heater. Be sure to record all settings and readings. Retain a copy of report for future reference.
- * Start up is now complete and heater may be placed into service.

PART 13 PIPING DIAGRAMS

Figure 31: Single Boiler Hydronic Heating Zoned Piping Arrangement

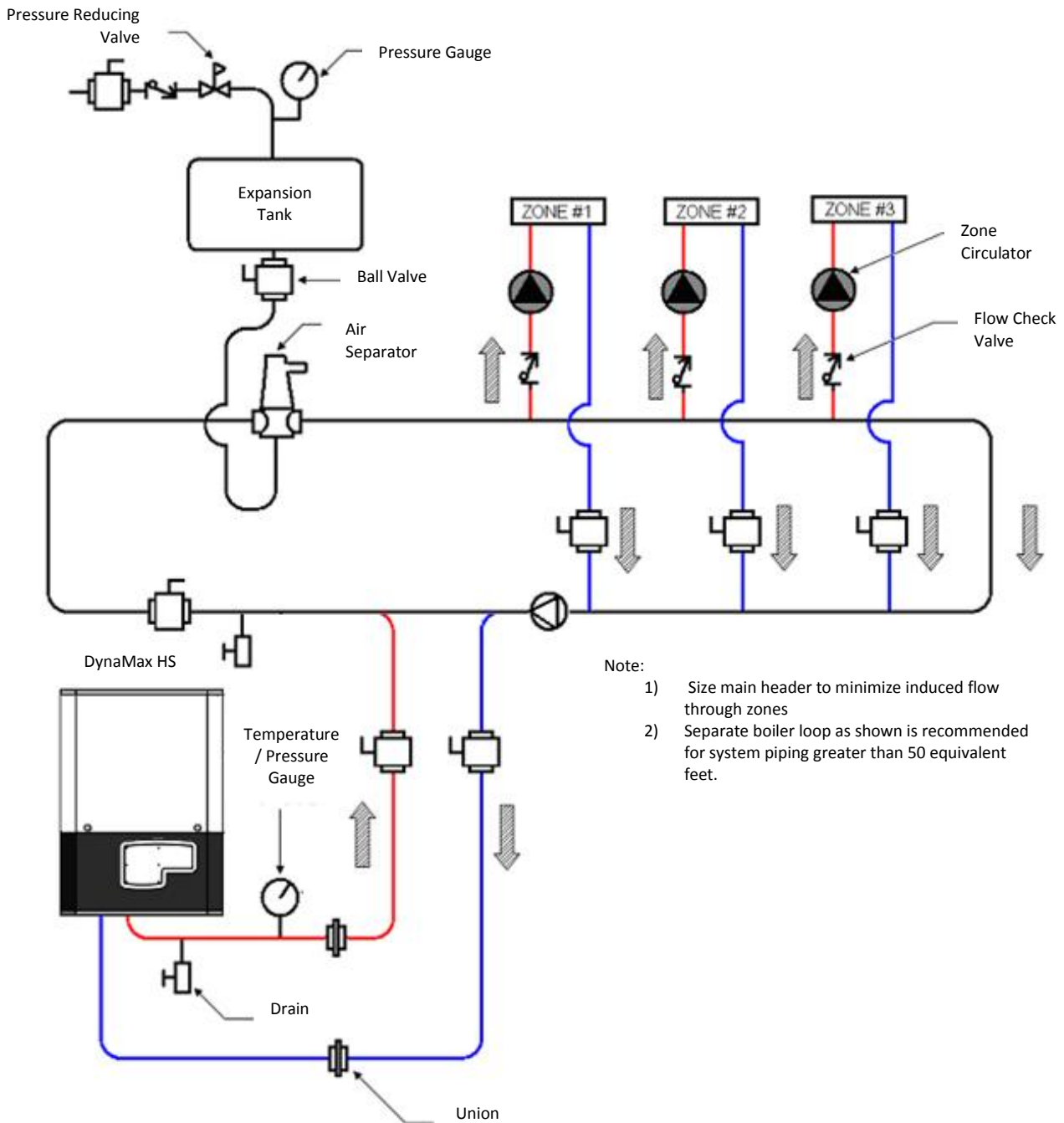
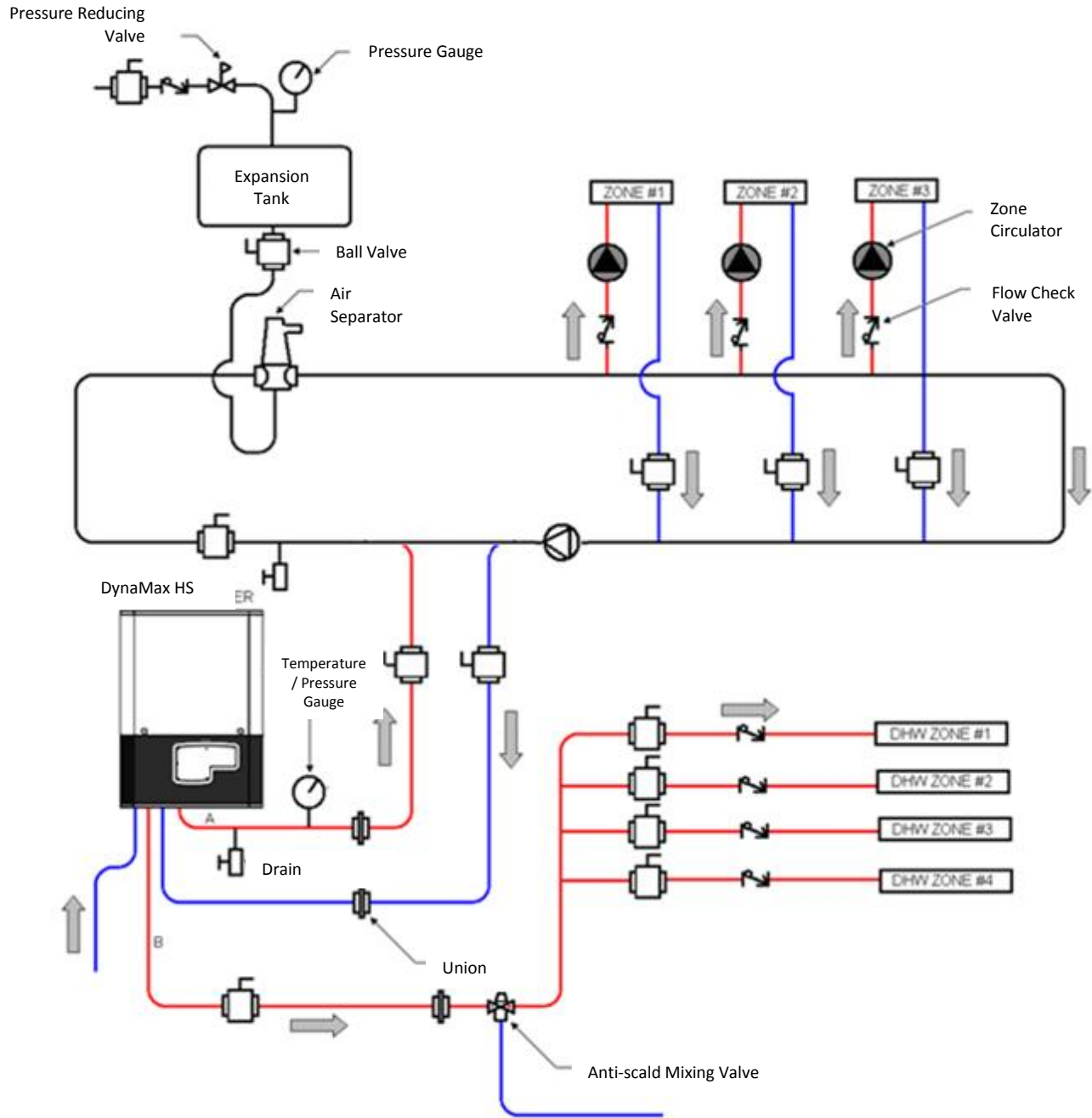

Figure 32: Single Combination Boiler Zoned Piping Arrangement



Note:

- 1) Size main header to minimize induced flow through zones
- 2) Separate boiler loop as shown is recommended for system piping greater than 50 equivalent feet.

Figure 33: Single Boiler Hydronic Heating & Indirect Storage Tank Zoned Piping Arrangement

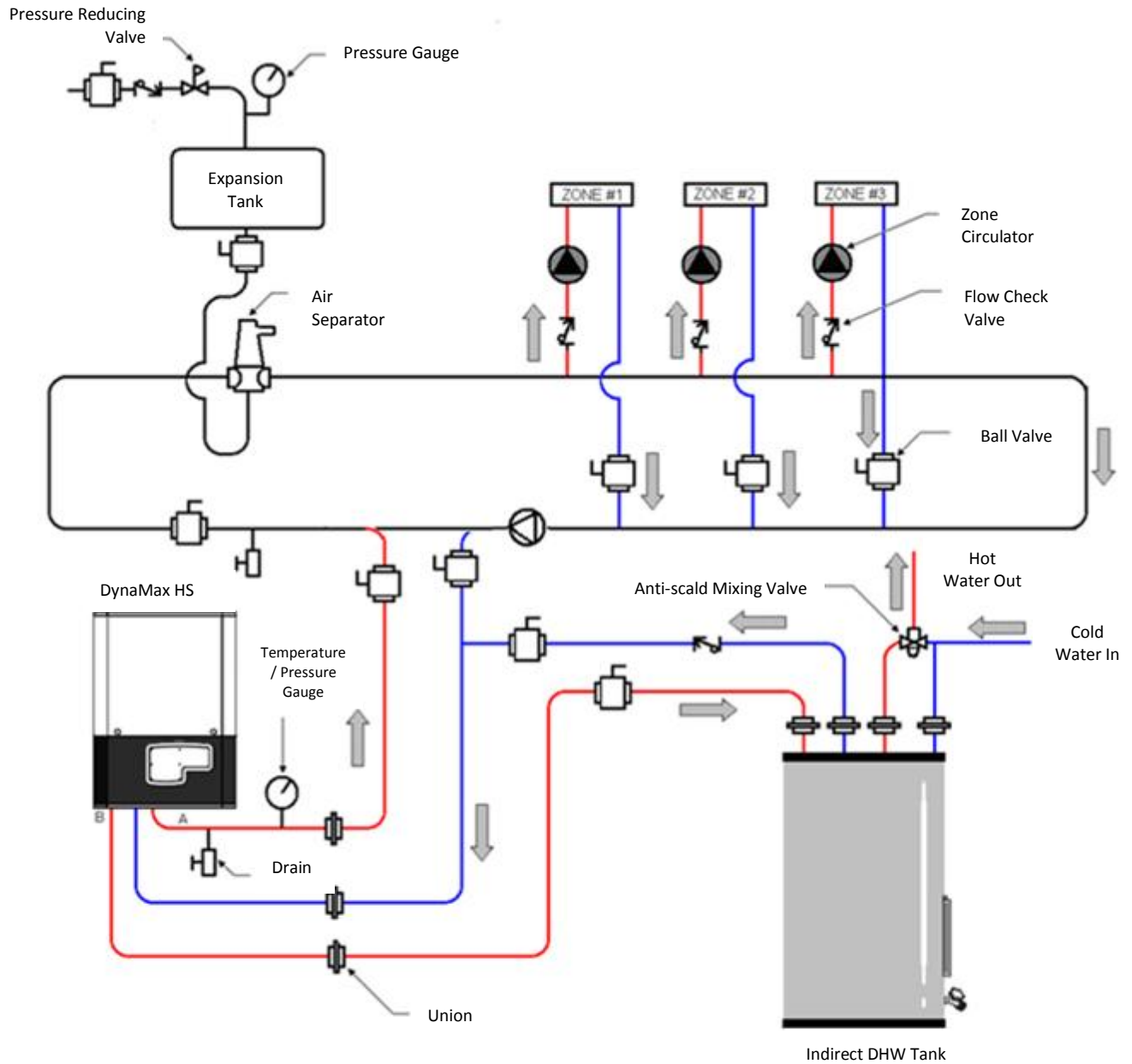

Note:

- 1) Size main header to minimize induced flow through zones
- 2) Separate boiler loop as shown is recommended for system piping greater than 50 equivalent feet.

Figure 34: Single Boiler Hydronic Heating & Direct Storage Tank Zoned Piping Arrangement

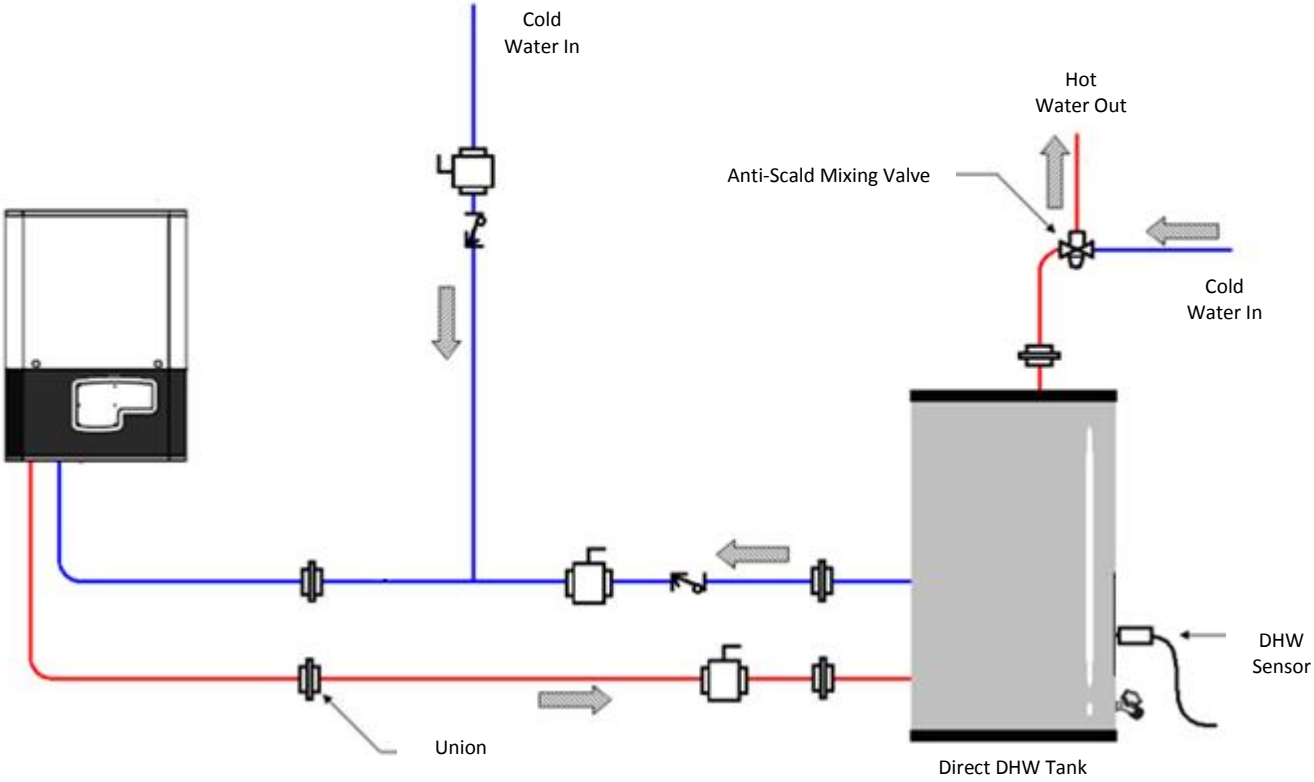
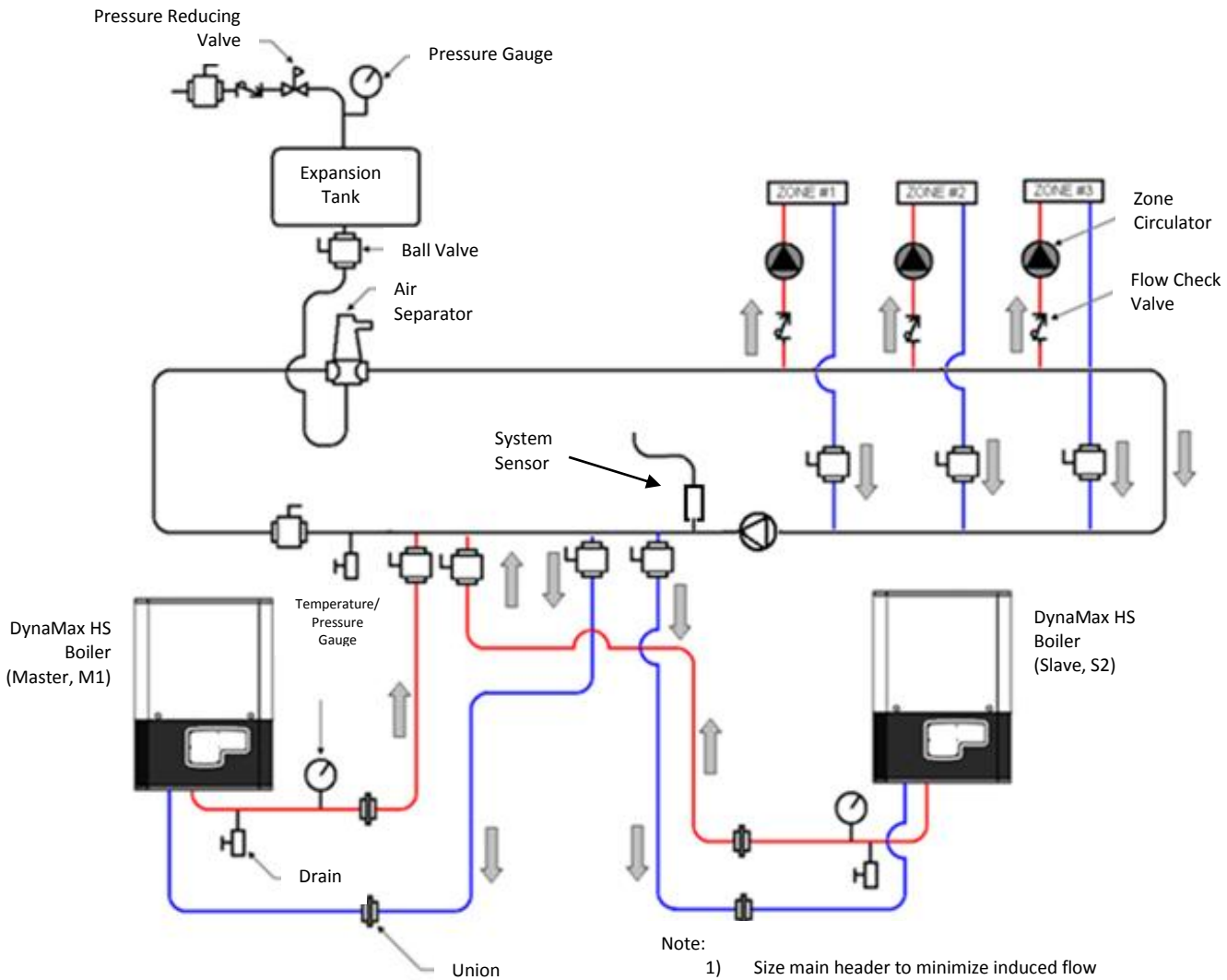

Figure 35: Multiple Boiler Hydronic Heating Zoned Piping Arrangement



- Note:
- 1) Size main header to minimize induced flow through zones
 - 2) Location of system sensor is based on single speed building circulator. If a variable speed building circulator is used, the system sensor must be placed in the building supply.

PART 14 EXPLODED VIEW & PARTS LIST

DYNAMAX HS WALL HUNG

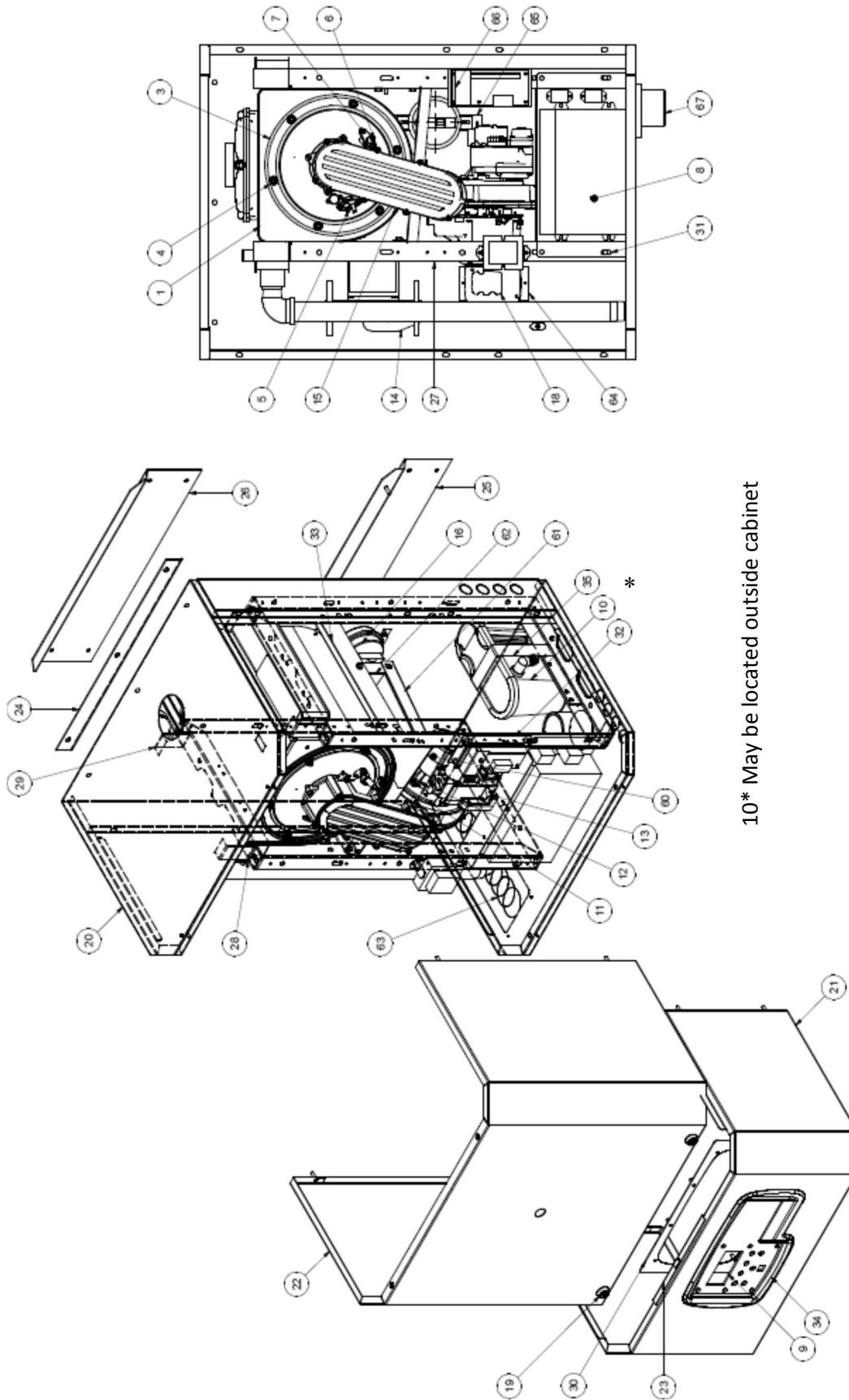

DYNAMAX HS FLOOR MOUNT

10* May be located outside cabinet

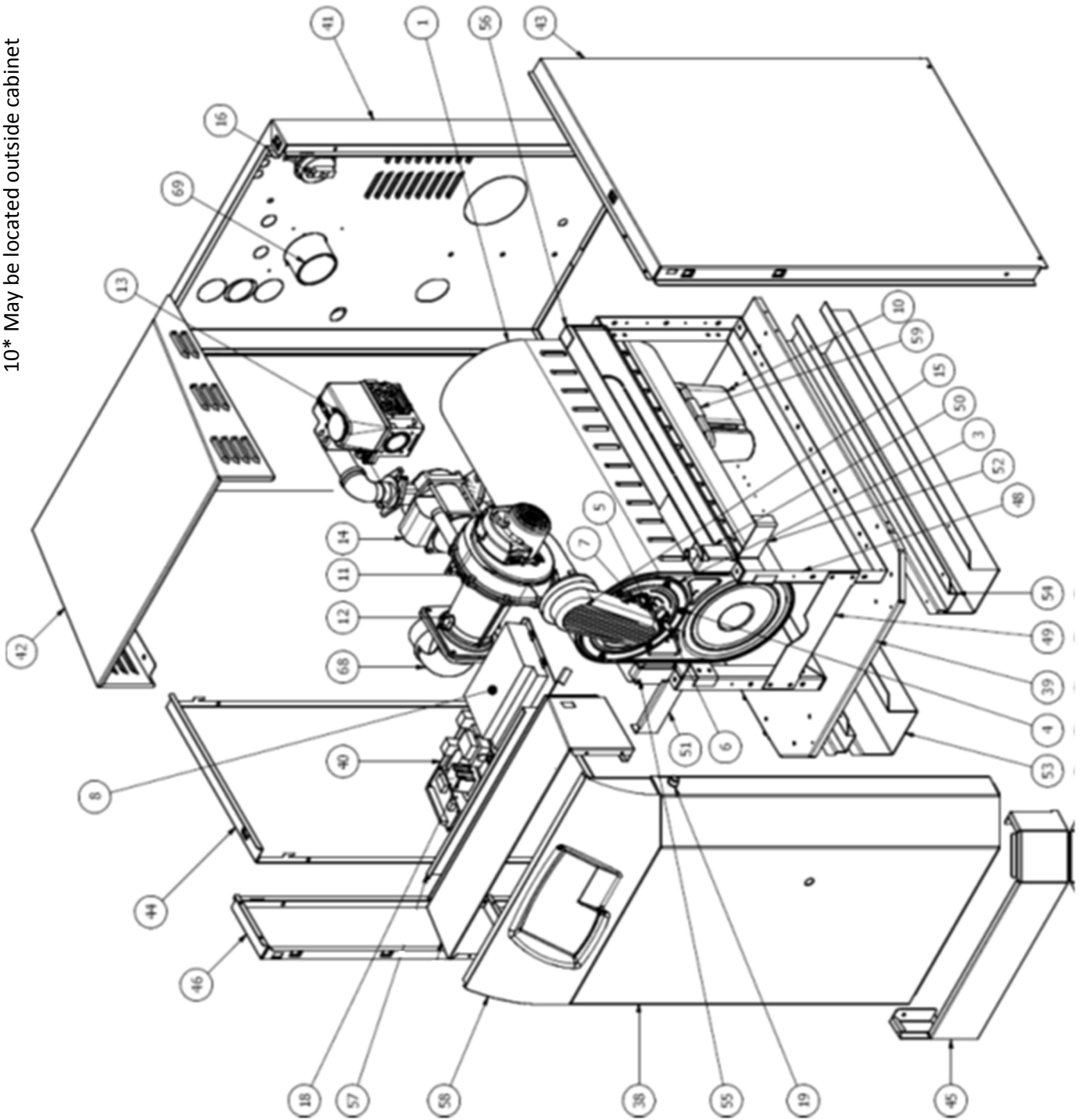

Ref #	Name of Part	Part ID	DynaMax HS Models													
			ALL	80	100	150	200	210	250	260	299	399	500	600	700	800
1	Heat Exchanger	4 + 1 Wall		X	X											
		5 + 2 Wall				X										
		8 + 4 Wall					X		X							
		8 + 4 Floor						X		X						
		10 + 6 Floor									X					
		15 + 8 Floor										X				
		18 + 10 Floor											X			
		21 + 11 Floor												X	X	
		24 + 12 Floor														
2	Burner	221.042.001-A		X	X											
		221.039.001-A				X										
		221.041.001-A					X	X	X	X						
		221.037.001-A									X					
		221.038.001-A										X	X			
		2437.003												X	X	
		2416.001														
3	Heat Exchanger Flange (complete with gaskets)	GM20-65-033-01		X	X	X										
		GM20-65-033-01					X	X	X	X	X	X	X			
		GM20-40-154-00												X	X	X
4	Heat Exchanger Flange Nuts	GM10-05-012	X													
5	Igniter	GM10-35-108-03		X	X	X	X	X	X	X	X	X	X			
		GM10-35-161-01												X	X	X
6	Flame Sensor	GM10-35-109-03		X	X	X	X	X	X	X	X	X	X			
		GM10-35-162-00												X	X	X
7	Igniter/Flame Sensor Screws	GM10-05-020	X													
8	DynaMax HS Controller	R7910B1009	X													
9	DynaMax HS Display	DSP49G2094B	X													
10	Condensate Neutralizer Box	90-15100-00		X	X	X	X		X							
		90-10030-01						X		X	X	X	X	X	X	
11	Combustion Fan	150503-00		X	X											
		150563-00				X	X	X	X	X						
		150563-05									X	X				
		55667.14002											X			
		150232-07												X	X	X
12	Venturi	45900-444-003		X	X											
		45900-444-001				X										
		45900-446-051					X	X	X	X						
		45900450-010									X	X				
		VMU300A1046											X	X	X	X
13	Gas Valve	VK8115V1341		X	X	X	X	X	X	X						
		VR8615VB1044									X	X				
		V8730C1015											X			

Ref #	Name of Part	Part ID	DynaMax HS Models													
			ALL	80	100	150	200	210	250	260	299	399	500	600	700	800
		V8730C1023												X	X	X
14	Hydronic Heating/Combination Pump	59896343 (UPS15-58FRC)		X	X	X	X	X								
		52722512 (UPS26-99FC)								X	X					
		PL30										X				
		PL36											X	X		
		E12													X	
		182212-667 (E22)														X
	DHW Pump	E7B		X	X											
		E9B				X	X	X	X	X						
		E12B									X	X				
		E33B											X			
		127091.1.1												X	X	X
15	Mixing Chamber	GM20-70-011-01		X	X	X										
		GM20-70-020-02					X	X	X	X	X	X				
		GM10-20-114											X			
		14-5540												X	X	X
16	Blocked Flue Switch	8021205256	X													
17	3-Way Valve Actuator	VC4011ZZ02/E		X	X	X	X	X	X	X	X					
		FSLF24										X	X	X	X	X
	3-Way Valve Body	VCZMR6100/E		X	X	X	X	X	X	X						
		VCZND6100/U									X					
		VBN3EM3POX										X	X			
		VBN3FP3POX											X	X	X	
18	High Limit	TCL085A	X													
		TCL110A	X													
19	¼ Turn Lock	Wall Hung	X													
		Floor Mount	X													
20	Wall Mount Back Panel	14-5402		X	X	X										
		14-5402-250					X		X							
21	Wall Mount Front Bottom Wrap	14-5403		X	X	X										
		14-5403-250					X		X							
22	Front Upper Wrap	14-5404		X	X	X										
		14-5404-250					X		X							
23	Restrain	14-5405		X	X	X	X		X							
24	Mounting Bracket	14-5406		X	X	X	X		X							
25	Lower Bracket	14-5407		X	X	X	X		X							
26	Wall Top Bracket	14-5408		X	X	X	X		X							
27	Support Frame Assembly	14-5409		X	X	X										
		14-5409-250					X		X							
28	Bracket Front	14-5410		X	X	X	X		X							
29	Rear Bracket	14-5411		X	X	X	X		X							
30	Bezel Stiffener Plate	14-5412		X	X	X	X		X							
31	Controller Plate	14-5413		X	X	X	X		X							
32	Electrical Conduit	14-5415		X	X	X										

Ref #	Name of Part	Part ID	DynaMax HS Models													
			ALL	80	100	150	200	210	250	260	299	399	500	600	700	800
	Plate	14-5415-250					X		X							
34	Plastic Bezel	Bezel HS		X	X	X	X		X							
35	Bracket for Neutralizer Box	14-5419		X	X	X	X		X							
36	Air Inlet/ Vent Adapter	FSA-HEX03		X	X	X	X	X	X	X	X	X				
37	Plate Heat Exchanger (Combination Models ONLY)	LB31-20X		X	X	X										
		LB31-40X					X	X	X	X	X	X				
		LB31-50X												X		
		LB31-80X													X	X
38	DynaMax HS Floor Front Panel	14-5501-20-25						X		X						
		14-5501									X	X	X	X	X	X
39	DynaMax HS Floor Base Panel	14-5502						X		X	X	X	X			
		14-5502-60-75												X	X	X
40	Control Panel Plate	14-5521						X		X	X	X	X	X	X	X
41	Floor Back Panel	14-5504-20-25						X		X						
		14-5504									X	X	X			
		14-5504-60-75												X	X	X
42	Top Cover Back	14-5505						X		X	X	X	X			
		14-5505-60-75												X	X	X
43	Side Panel Right	14-5506-20-25						X		X						
		14-5506									X	X	X			
		14-5506-60-75												X	X	X
44	Side Panel Left	14-5507-20-25						X		X						
		14-5507									X	X	X			
		14-5507-60-75												X	X	X
45	Front Panel Bottom	14-5508						X		X	X	X	X	X	X	
46	Side Panel Left Front	14-5509-20-25						X		X						
		14-5509									X	X	X	X	X	X
48	HX Support Frame	14-5511						X		X	X	X	X			
		14-5511-60-75												X	X	X
49	Support Plate	14-5512						X		X	X	X	X	X	X	
50	Bracket Right	14-5513-20-25						X		X						
		14-5513									X	X	X	X	X	X
51	Stand Off Left	14-5514						X		X	X	X	X	X	X	
52	Stand Off Right	14-5515						X		X	X	X	X	X	X	
53	Support Leg	14-5516						X		X	X	X	X			
		14-5516-60-75												X	X	X
54	Stiffener under Leg	14-5517						X		X	X	X	X			
		14-5517-60-75												X	X	X
55	Floor Bracket Left	14-5518-20-25						X		X						
		14-5518									X	X	X	X	X	X
56	Floor Rear Bracket	14-5520-20-25						X		X						
		14-5520									X	X	X	X	X	X

Ref #	Name of Part	Part ID	DynaMax HS Models														
			ALL	80	100	150	200	210	250	260	299	399	500	600	700	800	
57	Top Cover Assembly	14-5521							X		X	X	X	X	X	X	X
58	Dashboard	DASHBOARD HS							X		X	X	X	X	X	X	X
59	Bracket for Neutralizer Box	14-5525							X		X	X	X	X	X	X	X
60	Rubber Bushing	33-0101		X	X	X	X	X	X	X	X						
62	Condensate Pan Brace	14-5417		X	X	X	X			X							
		14-5417-250							X		X						
63	Cover Plate	14-5421		X	X	X											
		14-5421-250					X			X							
66	Electrical Strip Plate Protector	14-5420	X														
67	Air Intake Adapter	44-0008		X	X	X	X			X							
68	Plastic Flange with 3" Street Elbow	44-0009											X				
	4" Air Intake Box	14-5551												X	X		
	5" Air Intake Box	14-5546															X
69	3" Air Intake Adapter	44-0010											X				
	4" Air Intake Adapter	14-5559												X	X		
	5" Air Intake Adapter	14-5556															X
70	Condensate Pan	14-5418		X	X												
		14-5414				X											
		14-5414-250					X			X							
72	Plate Heat Exchanger Bracket	14-5424		X	X	X											
		14-5424-200					X			X							
73	Transformer Mounting Plate	14-5541		X	X	X	X			X							
74	Igniter Gasket	GM10-25-018	X														
75	Flame Sensor Gasket	GM10-25-004	X														
76	Burner Refractory	GM10-25-098-01		X	X	X	X			X							
		GM10-25-107-02							X		X	X	X	X			
		GM10-25-128-03													X	X	X
77	Automatic Air Vent	FV-4M1	X														
78	Terminal Board	TB-SOLA	X														
79	On/Off Switch	ESWRB141D1121/ACC-F	X														
80	75VA Transformer	HCT-01E0BB06	X														
81	Inlet Sensor	NTC-SENSOR-002	X														
82	Outlet/System Sensor	NTC-SENSOR-002	X														

Ref #	Name of Part	Part ID	DynaMax HS Models														
			ALL	80	100	150	200	210	250	260	299	399	500	600	700	800	
83	Flue Sensor	NTC-SENSOR-003	X														
84	Outdoor Sensor	NTC-SENSOR-004	X														
85	DHW Sensor (Clip on)	NTC-SENSOR-001	X														
86	Gas Valve Elbow	45900400-132/B		X	X	X	X	X	X	X							
		45900400-144/B									X	X					
87	Gas Valve Wire Harness	45900441-015B		X	X	X											
		45900429-007B					X	X	X	X	X	X					
88	Relief Valve	10-407-05		X	X	X	X	X	X	X							
		10-604-10									X	X	X				
89	Wiring Harness	77-0035		X	X	X	X		X								
		77-0036						X		X	X	X	X	X	X	X	X
90	Firing Valve	USA0509101T		X	X	X	X	X	X	X							
		13105									X	X					
		13106											X	X	X	X	
91	DynaMax HS Fan Discharge Orifice	14-0377-80		X	X												
		14-0377-100				X											
		14-0377-250					X	X									
92	Expandable Air Inlet Adapter w/o Pressure Test Point	14-0378		X	X	X	X		X								
93	Expandable Air Inlet Adapter	1056-22		X	X	X	X		X								
94	Flex Pipe	2" Diameter		X	X	X	X	X	X	X	X	X					
		3" Diameter											X				
		4" Diameter												X	X		
		5" Diameter															X
95	Flexible Stainless Steel Pipe 1" X 11"	66-0075	X														
96	Flexible Stainless Steel Pipe 1/2" X 11"	66-0073	X														
97	Manual Shutoff Valve Kit	50002653-001	X														
98	Rear Vent Adapter	GM10-15-991-01						X		X							
		GM10-15-992-01									X	X	X				
99	Metal Latch	6521-00-0551-YT						X		X	X	X	X	X	X	X	X
100	Strike	7800-02						X		X	X	X	X	X	X	X	X
102	Plastic to Stainless Steel Vent Adapter	300566		X	X	X	X	X	X	X							
		300611									X	X	X				

Ref #	Name of Part	Part ID	DynaMax HS Models														
			ALL	80	100	150	200	210	250	260	299	399	500	600	700	800	
	Stainless to Plastic Vent Adapter	FS0604PVCR												X			
		300537													X	X	
103	Rubber Air Sleeve	1056-22		X	X	X	X	X	X	X	X	X	X				
		1056-33												X			
		1056-44													X	X	
		1056-55															X
104	Burner Gasket	GM10-25-074-09		X	X	X	X	X	X	X	X	X	X				
		GM10-25-135-02													X	X	X
105	Fan Gasket/ Mixing Chamber Gasket	33-0036		X	X	X	X	X	X	X							
		33-0037		X	X	X	X	X	X	X	X	X					
		33-0038												X			
		33-0057													X	X	X
106	Current Transformer (Combination Models only)	RIBXRA	X														
107	Target disk	GM10-25-189-00	X														
108	Washer for Target disk	GM10-15-014-01	X														
109	Counter sunk head screw M4x16 for target disk	GM10-05-021	X														
110	Vent Gasket	GM10-25-153-00 (Black)													X	X	X
		GM10-25-178-01 (Blue)													X	X	X
111	Pump Delay Relay	LY1F	X														
112	Gas Valve Relay	1649341-8	X														
113	Rear Thermal Fuse	GM10-35-263-00										X	X	X	X	X	X
114	Mixing Chamber Screws	GM10-05-011	X														
115	Front Thermal Fuse	GM10-35-377-00										X	X	X	X	X	X
116	Front Strut	14-8037		X	X	X	X		X								

Not shown in Exploded View
Part Recommended spare parts

PART 15 ELECTRICAL DIAGRAMS

15.1 DM 80- 299 INTERNAL WIRING DIAGRAM

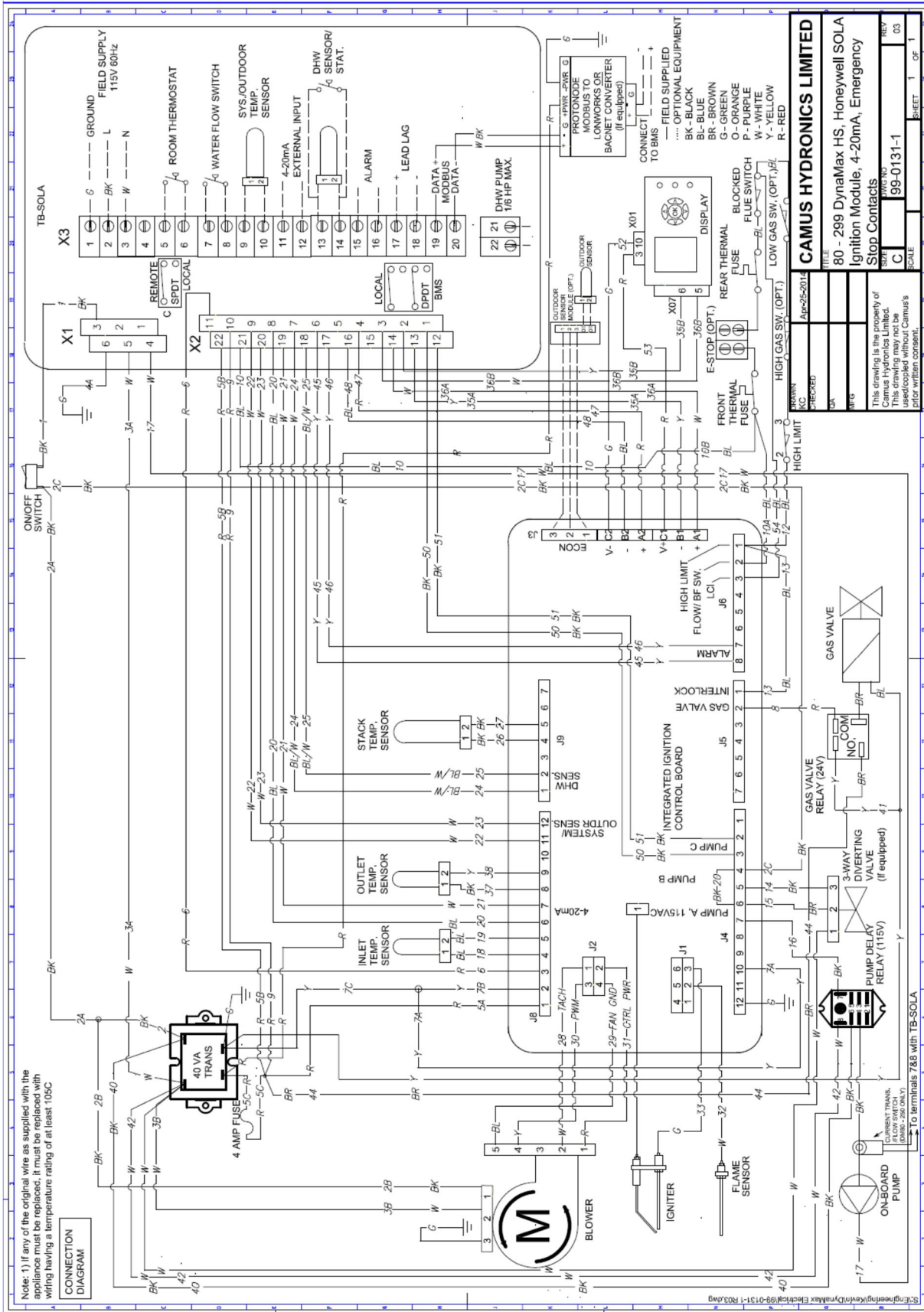

15.2 DM 399 – 800 INTERNAL WIRING DIAGRAM

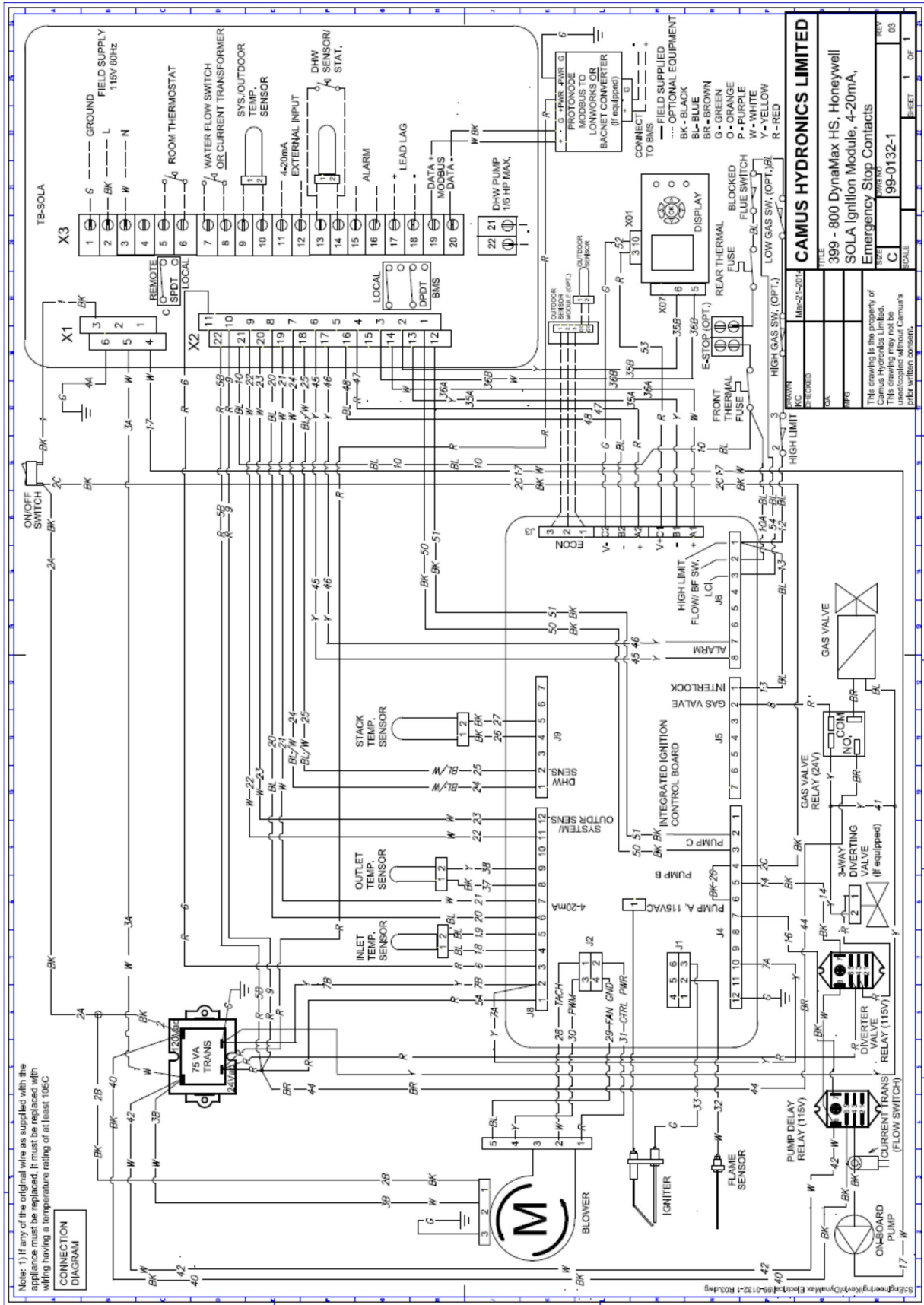

Note: 1) If any of the original wire as supplied with the appliance must be replaced, it must be replaced with wiring having a temperature rating of at least 105C

CONNECTION DIAGRAM

CAMUS HYDRONICS LIMITED	
TITLE	399 - 800 DynaMax HS, Honeywell SOLA Ignition Module, 4-20mA, Emergency Stop Contacts
REV	03
SCALE	1 OF 1
SHEET	1 OF 1

This drawing is the property of Camus Hydraulics Limited. It is to be used only for the specific application and must not be reproduced or used in any way without Camus's prior written consent.

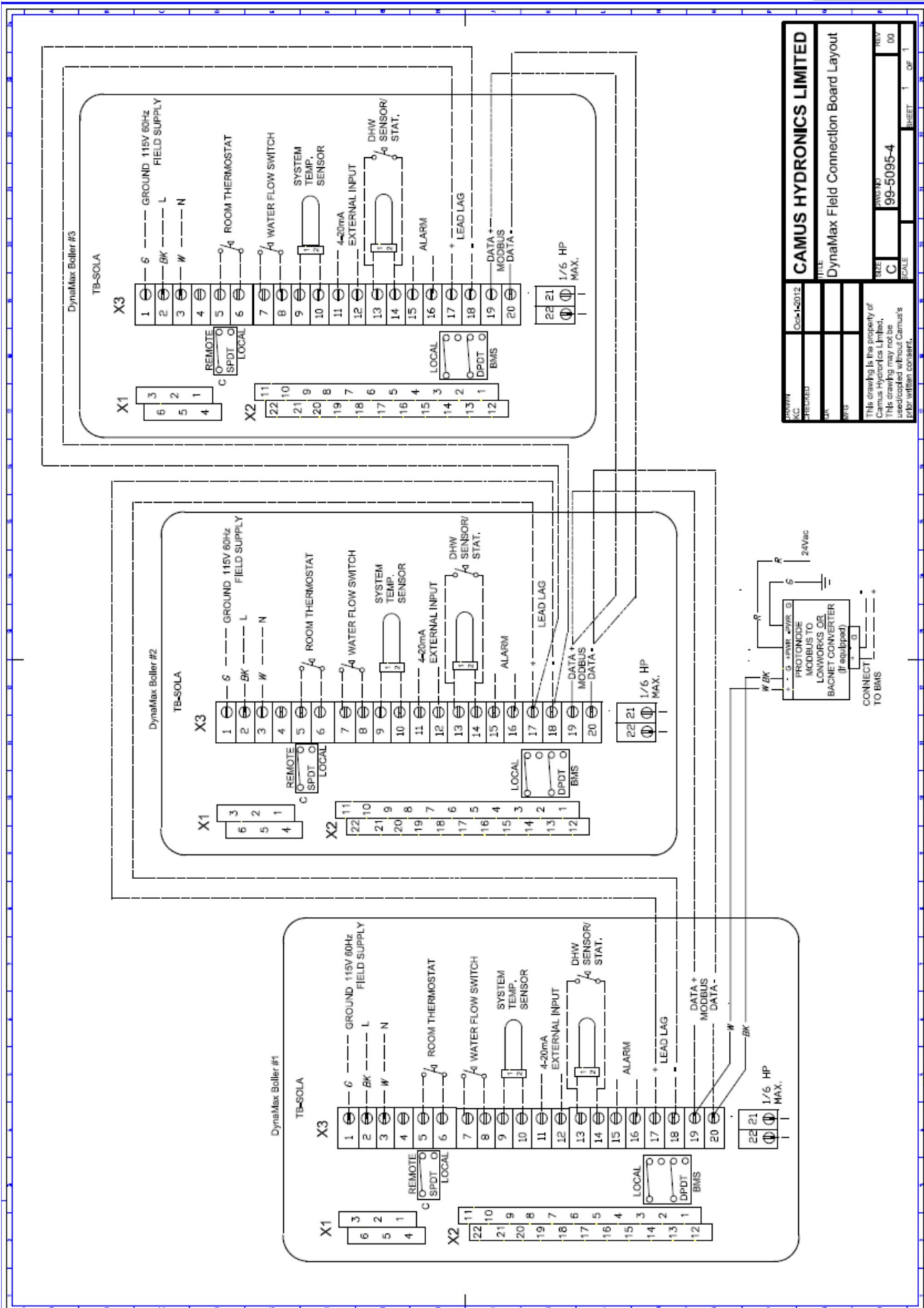

REV	00	DATE	09-14-2013
BY		SCALE	
CHK		PROJECT	
APP		DESCRIPTION	
CAMUS HYDRONICS LIMITED			
DynaMax Field Connection Board Layout			
DRAWING NO.		REV	00
PROJECT NO.		SCALE	
DATE		PROJECT	
BY		DESCRIPTION	
CHK		PROJECT	
APP		DESCRIPTION	
This drawing is the property of Camus Hydronics Limited. This drawing may not be used or reproduced without Camus's written consent.			

15.2 FIELD WIRING

All wires being placed into the terminal block should be horizontal for at least an inch to ensure sufficient electrical conductivity.

15.2.1 System Sensor

The temperature of the primary return can be controlled by installing a system sensor. The system sensor must be used in all lead lag modes, and must be enabled through the DynaMax HS controller.

15.2.2 Lead Lag Setup

To setup a lead lag system a master boiler must be chosen, and the other boilers connected to it in this system are designated as slaves through sequential Modbus addresses.

Connect the system sensor to the master boiler. The master boiler will use the water temperature in the primary loop to control the operation of the lead lag setup.

If outdoor reset is desired, the outdoor sensor needs to be connected to the Outdoor Sensor location on the DynaMax HS terminal board on boiler 2 (B-2). If the outdoor sensor is not connected to the Master boiler the DynaMax HS Controller will maintain a fixed water temperature that is programmed into the control.

If a remote enable signal is available, it needs to be connected to the Remote Operator terminals on the DynaMax HS terminal board. If the boiler is required to run continuously the switch can be placed in the 'Local' position.

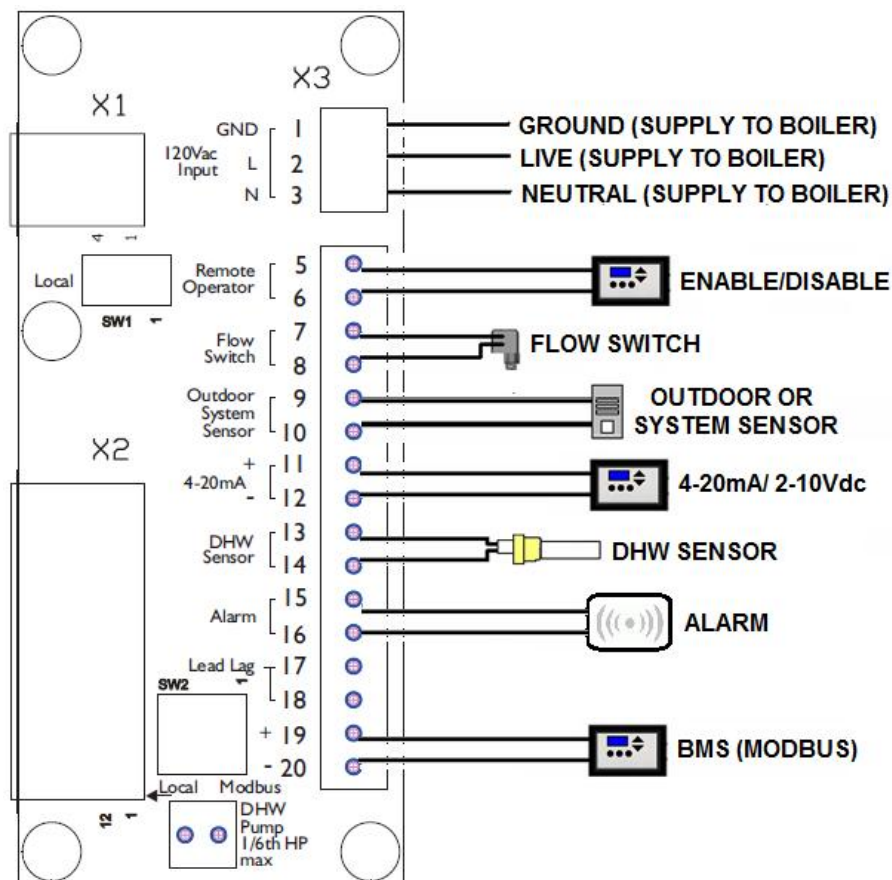

15.5 DETAILED CONNECTOR DESCRIPTION

Connector	Pin #	Connector Description
J1	2	Flame sensor
	3	Igniter ground
J2	1	Blower tach signal
	2	Blower Vdc power
	3	Blower PWM signal
	4	Blower ground signal
J3	A1	Modbus +
	B1	Modbus -
	C1	+Vdc Display
	A2	Lead Lag, Modbus +
	B2	Lead Lag, Modbus -
	C2	-Vdc Display
J4	2, 3	DHW Pump, 1/6hp
	4	24Vac or 115Vac for pump contact
	5,6	3-way diverter valve
	7	Boiler pump contact
	10	24Vac return
	12	Ground
J5	1	Interlock
	2	Gas Valve contact
J6	1	Blocked Flue
	2	Flow switch
	3	Load Control Input (LCI)
	7,8	Alarm, dry contacts

Connector	Pin #	Connector Description
J8	1	24Vac for SOLA
	2	24Vac return
	3	Remote enable/disable signal
	4,5	Inlet sensor
	6,7	4-20mA Input
	8,9,10	Outlet sensor, high limit
	11, 12	System or Outdoor sensor
J9	1,2	DHW sensor
	4,5	Stack sensor

CONDENSING BOILER LIMITED WARRANTY

Camus® Hydronics Limited ("Camus®") extends the following LIMITED WARRANTY to the owner of this appliance, provided that the product has been installed and operated in accordance with the Installation Manual provided with the equipment. Camus® will furnish a replacement for, or at Camus® option repair, any part that within the period specified below, shall fail in normal use and service at its original installation location due to any defect in workmanship, material or design. The repaired or replacement part will be warranted for only the unexpired portion of the original warranty.

THIS LIMITED WARRANTY DOES NOT COVER

1. Failure to properly install, operate or maintain the equipment in accordance with Camus® manual
2. Abuse, alteration, accident, fire, flood, foundation problems and the like
3. Sediment or lime build-up, freezing, or other conditions causing inadequate water circulation
4. Pitting and erosion caused by high water velocity;
5. Failure of connected systems devices, such as pump or controller
6. Use of non-factory authorized accessories or other components in conjunction with the system;
7. Failing to eliminate air from, or replenish water in, the connected water system
8. Chemical contamination of combustion air or use of chemical additives to water
9. Production of noise, odours, discolouration or rusty water
10. Damage to surroundings or property caused by leakage or malfunction
11. All labour costs associated with the replacement and/or repair of the unit
12. Any failed component of the hydronic system not manufactured as part of the boiler.

HEAT EXCHANGER

If within TWELVE years after initial installation of the appliance, a heat exchanger shall prove upon examination by Camus® to be defective in material, thermal shock, leakage or workmanship, Camus® will exchange or repair such part or portion on the following pro rated limited warranty

Years into Warranty	% of List Price
8	30
9	40
10	50
11	60
12	70

This term is reduced to SIX years if the appliance is used for other than hydronic space heating. Heat Exchanger shall be warranted for (20) years from date of installation against "Thermal Shock" (excluded, however, if caused by appliance operation at large changes exceeding 150°F between the water temperature at inlet and appliance temperature or operating at temperatures exceeding 210°F).

BURNER

If within FIVE years after initial installation of the appliance a burner shall prove upon examination by Camus® to be defective in material or workmanship, Camus® will exchange or repair such part or portion.

ANY OTHER PART

If any other part fails within one (1) year after installation, or eighteen (18) months from date of factory shipment based on

Camus® records, whichever comes first. Camus® will furnish a replacement or repair that part. Replacement parts will be shipped f.o.b. our factory.

DURATION OF LIMITED WARRANTY

Any limited warranty, including the warranty of merchantability imposed on the sale of the boiler under the laws of the state or province of sale are limited in duration to one year from date of original installation.

STATE LAW & LIMITED WARRANTY

Some states or provinces do not allow:

- a) Limitations on how long an implied warranty lasts
 - b) Limitations on incidental or consequential damages.
- The listed limitations may or may not apply to you. This warranty gives you specific legal rights, and you may also have other rights which may vary from state to state and province to province.

CONDITIONS

We will not:

- a) Repair or replace any boiler, or part, subject to conditions outlined in 'This Limited Warranty Does Not Cover'
- b) Reimburse any costs associated with repair and/or replacement
- c) Replace and/or repair any boiler without complete model number/serial number
- d) Replace any boiler without prior receipt of actual rating plate from the appliance.

HOW TO MAKE A CLAIM

Any claim under this warranty shall be made directly to Camus® Hydronics Limited Canadian Head Office

SERVICE LABOR RESPONSIBILITY

Camus® shall not be responsible for any labour expenses to service, repair or replace the components supplied. Such costs are the responsibility of the owner.

DISCLAIMERS

Camus® shall not be responsible for any water damage. Provisions should be made that in the event of a water/appliance or fitting leak, the resulting flow of water will not cause damage to its surroundings.

Name of Owner			
Name of Dealer			
Address			
Model No.			
Serial #:			
Date of Installation:		Date of Initial Operation:	

6226 Netherhart Road, Mississauga, Ontario, L5T 1B7, CANADA

CAMUS® Hydronics is a manufacturer of replacement parts for most copper finned

water heaters and heating boilers as well as a

supplier of specialty HVAC products. Our service line is open 24 hours, 7 days a week!

The CAMUS® CERTIFIED! Seal assures you that Reliability, Efficiency & serviceability are built

into every single unit! For more information



on our innovative products from CAMUS® Hydronics Limited, call 905-696-7800 today.



CAMUS® HYDRONICS LTD.

6226 Netherhart Road, Mississauga, Ontario L5T 1B7

TEL: 905-696-7800 FAX: 905-696-8801