

INSTALLATION OPERATION AND SERVICE MANUAL MICOFLAME GRANDE SERIES



GAS FIRED COMMERCIAL COPPER TUBE BOILERS

FOR HYDRONIC HEATING
Models; MFH2010, 2500, 3000, 3500, 4000

HOT WATER SUPPLY
Models; MFW2010, 2500, 3000, 3500, 4000

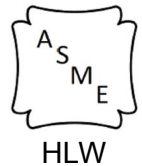
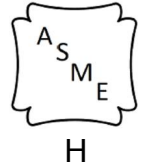

WARNING:

If the information in these instructions is not followed exactly, a fire or explosion may result causing property damage, personal injury or death

Do not store or use gasoline or other flammable vapours and liquids in the vicinity of this or any other appliance.

WHAT TO DO IF YOU SMELL GAS

- Do not try to light any appliance,
- Do not touch any electrical switch; do not use any phone in your building,
- Immediately call your gas supplier from a neighbour's phone. Follow the gas supplier's instructions,
- If you cannot reach your gas supplier, call the fire department.

Qualified installer, service agency or the gas supplier must perform installation and service.

To the installer: After installation, these instructions must be given to the end user or left on or near the heater.

To the End User: This booklet contains important information about this heater. Retain for future reference.

CAMUS HYDRONICS LTD.
6226 Netherhart Road, Mississauga, Ontario, L5T 1B7

Table of Contents

1	GENERAL INSTRUCTIONS	1
2.	LOCATION	1
3.	AIR REQUIRED FOR COMBUSTION AND VENTILATION	2
4.	ELECTRICAL WIRING.....	3
5.	GAS SUPPLY	3
6.	VENTING	4
6.1	OUTDOOR VENTING	5
6.2	STANDARD VENTING	6
6.3	SIDEWALL VENTING	6
6.4	OUTDOOR AIR KIT.....	6
6.5	FILTER KIT.....	6
6.6	CONDENSER HEAT RECOVERY MODULE (CHRM)	7
7	WATER PIPING	9
7.1	PROTECTION DEVICES.....	9
7.2	FREEZE PROTECTION.....	10
7.3	CHILLED WATER SYSTEMS	10
7.4	HEATING SYSTEM PIPING	11
7.5	LOW WATER TEMPERATURE SYSTEMS.....	11
7.6	INSTANTANEOUS WATER HEATER.....	11
7.7	HOT WATER SYSTEM PIPING	11
8	INSTRUMENTATION AND CONTROLS	14
8.1	SAFETY CONTROLS.....	15
8.2	CONTROL PANEL.....	15
8.3	CONTROL DEVICES.....	18
8.4	MODE 1 & 2: SETPOINT OPERATION: VIEW DISPLAY	19
8.5	MODE 1 & 2: SETPOINT OPERATION: ADJUST DISPLAY	20
8.6	MODE 3: SETPOINT OPERATION: VIEW DISPLAY.....	21
8.7	MODE 3: SETPOINT OPERATION: ADJUST DISPLAY	22
8.8	MODE 4 & 5: OUTDOOR RESET OPERATION: VIEW DISPLAY	23
8.9	MODE 4 & 5: OUTDOOR RESET OPERATION: ADJUST DISPLAY.....	24
8.10	MODE 6: OUTDOOR RESET OPERATION: VIEW DISPLAY.....	26
8.11	MODE 6: OUTDOOR RESET OPERATION: ADJUST DISPLAY	27
8.12	MODE 7 & 8: EXTERNAL TEMPERATURE TARGET OPERATION: VIEW DISPLAY.....	27
8.13	MODE 7 & 8: EXTERNAL TEMPERATURE TARGET OPERATION: ADJUST DISPLAY.....	28
9	OPERATION.....	30
9.1	START-UP	30
9.2	STAGING OPERATION	31
9.3	OPERATION SQUENCE	33
10	PILOT AND MAIN BURNER FLAMES	34
10.1.	MAIN BURNER	34
10.2.	PILOT BURNER	35
11	OPERATION AND SERVICE	36
12	LIGHTING INSTRUCTIONS	37
13	TROUBLE SHOOTING GUIDE	38
14	TYPICAL GAS TRAIN.....	39
15	ELECTRICAL DIAGRAMS	39
16	EXPLODED VIEW MicoFlame Grande.....	42
17	EXPLODED VIEW MicoFlame Grande Outdoor and/or Condensing	43
18	MICOFLAME GRANDE REPLACEMENT PARTS LIST.....	44
	WARRANTY	47

Camus Hydronics proudly introduces MicoFlame Grande commercial water heaters / hydronic boilers. The MicoFlame Grande boiler is a fan assisted boiler based on a push through design which offers several venting options. These gas-burning appliances are thoughtfully designed for easy operation and maintenance. We are confident that you will come to appreciate the benefits of our product.

1 GENERAL INSTRUCTIONS

The installation of this heater must conform to the requirements of the authority having jurisdiction or, in the absence of such requirements, to the current National Fuel Gas Code, ANSI Z223.1 or current CAN/CGA B149 Installation Codes. All electrical wiring must be done in accordance with the requirements of the authority having jurisdiction or, in the absence of such requirements, with the National Electrical Code, ANSI/NFPA 70 or the Canadian Electrical Code Part I, CSA C22.1 Electrical Code.

Vent installations must be in accordance with Part 7, Venting of Equipment, of the current National Fuel Gas Code, ANSI Z223.1, or Section 7, Venting Systems and Air Supply for Appliances, of the current CAN/CGA B149, Installation Codes and applicable provisions of the local building codes.

When required by the authority having jurisdiction, the installation must conform to the Standard for Controls and Safety Devices for Automatically Fired Boilers, ANSI/ASME CSD-1.

The qualified installer shall instruct the end user in the safe and correct operation of this appliance and shall ensure that the heater is in safe working order prior to leaving the job site.

WARRANTY:

Factory warranty shall apply only when the boiler is installed in accordance with local plumbing and building codes, ordinances and regulations, the printed instructions provided with it and good industry practices.

Excessive water hardness causing a lime build-up in the copper coils or tubes is not a fault of the boiler and is not covered by warranty. Consult the factory for recommendations for use in hard water areas.

Excessive pitting and erosion on the inside of the copper tube may be caused by high water velocity or the use of an undersized boiler for a

DHW application and is not covered by warranty.

Using or storing corrosive chemicals in the vicinity of this boiler can rapidly attack the copper tubes and voids warranty.

The primary heat exchanger of this boiler is intended to operate under non-condensing conditions. Inlet temperatures must be maintained at 115°F or higher. Warranty is void if the primary heat exchanger is allowed to operate in condensing mode.

Damage caused by freezing or dry firing voids warranty.

This boiler is not to be used for temporary heating of buildings under construction.

2. LOCATION

Install this appliance in a clean, dry location with adequate air supply and close to a good vent connection.

Do not locate this appliance in an area where it will be subject to freezing unless precautions are taken.

The appliance is approved for installation directly on combustible flooring and should be located close to a floor drain in an area where leakage from the appliance or connections will not result in damage to the adjacent area or to lower floors in the structure.

If necessary a suitable drain pan must be installed under the appliance.

If the appliance is installed above the level of the building's radiation system, a low water cutoff device must be installed in the appliance outlet at the time of installation. Some local codes require the installation of a low water cutoff on all systems.

Locate the appliance so as to provide adequate clearance for inspection and service all around the unit. It is recommended that 24" be provided for the top and sides and 48" for the front.

This appliance is suitable for alcove installation with minimum clearances to combustibles as follows:

Table 1 – Clearance to Combustibles

TOP:	12"
SIDES:	12"
REAR:	12"
VENT:	6"
FLOOR	0"

Figure 1 – Appliance Dimensions

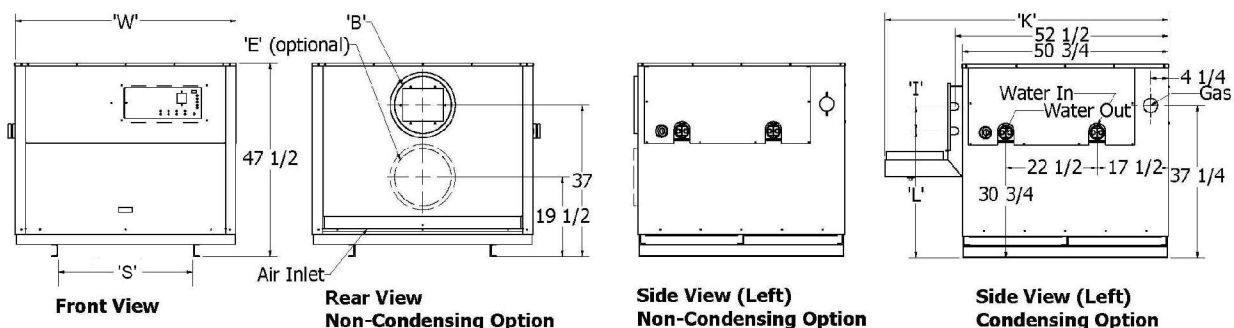

Table 2 – Appliance Dimensions

Model	'I'	'K'	'L'	'W'	'S'	Water Connection**	Gas Connection	B' Dia. Venting*			E' Dia. Air Inlet (Optional)
								Outdoor	Condensing or Sidewall	Standard	
MF2000	6"	68"	34 5/8"	54 5/8"	33 3/8"	3"	1 1/2"	12"	12"	14"	12"
MF2500	6"	72"	34 5/8"	78 7/8"	58"	3"	2"	14"	14"	16"	14"
MF3000	6"	72"	34 5/8"	78 7/8"	58"	3"	2"	14"	14"	16"	14"
MF3500	6"	72"	34 5/8"	103"	81 3/4"	4"	2 1/2"	16"	16"	18"	16"
MF4000	6"	72"	34 5/8"	103"	81 3/4"	4"	2 1/2"	16"	16"	18"	16"

* Non-condensing models are shipped with standard vent opening size unless sidewall vent is specified.

** Water connections are 3" grooved at header

3. AIR REQUIRED FOR COMBUSTION AND VENTILATION

Provisions for combustion and ventilation air must be in accordance with:

- Section 5.3. Air for combustion and Ventilation, of the current National Fuel Gas Code, ANSI Z223.1, or;
- Sections 7.2, 7.3 or 7.4 of the current CAN/CGA B149 Installation Codes, and;
- Applicable provisions of the local building codes.

The operation of exhaust fans, compressors, air handling units etc. can rob air from the room, creating a negative pressure condition leading to reversal of the natural draft action of the venting system. Under these circumstances an engineered air supply is necessary.

If the heater is to be installed near a corrosive or potentially corrosive air supply, the heater must

be isolated from it and outside air should be supplied as per code.

Potentially corrosive atmospheres will result from exposure to permanent wave solution, chlorinated waxes and cleaners, chlorine, water softening chemicals, carbon tetrachloride, halogen based refrigerants, Freon cleaning solvents, hydrochloric acid, cements and glues, masonry washing materials, antistatic fabric softeners, dry cleaning solvents, degreasing liquids, printing inks, paint removers, etc.

4. ELECTRICAL WIRING

All electrical wiring to the appliance must be electrically bonded to ground in accordance with the requirements of the authority having jurisdiction or, in the absence of such requirements, with the National Electrical Code, ANSI/NFPA 70 or the Canadian Electrical Code Part I, CSA C22.1, Electrical Code.

Provide disconnecting means of sufficient rating within sight of the appliance. These heaters require an 115V 60 Hz supply. A 15-amp breaker is sufficient for appliances with input up to 3,000 MBTUH. For appliances with input over 3,000 MBTUH, use a 20-amp breaker. The pump requires a separate power supply.

Electrical connections must be made so that the circulator will operate before the gas valve can open. At no time may the control system allow the burner to fire without water flowing in the system.

Use minimum 18-gauge conductor for 24-volt field wiring to appliance. Splicing of wires is not recommended. Use sealed tight conduit suitable for outdoor use for outdoor installations. Use terminal strip provided inside control panel for low water cut-off and remote controller. Refer to wiring diagram provided with appliance.

5. GAS SUPPLY

This appliance is intended to operate at inlet gas pressures not exceeding ½ PSI (14"W.C.).

The appliance and its individual gas shut-off valve must be disconnected from the supply piping, when pressure testing the gas supply piping at pressures above ½ PSI. Provide a trap (drip leg) as close to the heater as possible. Install a good joint union and manual shut-off valve in the gas line near the heater to allow easy removal of the gas control assembly. The gas pressure at the appliance's inlet must be set in accordance with Table 3.

Table 3 – Gas Pressures at Inlet to Appliance

	PROPANE	NATURAL GAS
Minimum (inches W.C.)	11	4
Maximum (inches W.C.)	11	7

The gas supply line must be of adequate size to prevent undue pressure drop and must never be smaller than the size of the connection on the heater. Table 4 lists recommendation for gas pipe sizes. Before operating the appliance, the complete gas train and all connections must be tested using non-corrosive soap solution.

Table 4 – Gas pipe size for distance from natural gas meter or propane second stage regulator

Input Btu/Hr	0-100 FT*	
	NAT.	L.P.
2,000,000	2 ½"	2"
2,500,000	3"	2 ½"
3,000,000	3"	2 ½"
3,500,000	3"	2 ½"
4,000,000	4"	2 ½"
Input Btu/Hr	100-200 FT*	
	NAT.	L.P.
2,000,000	3"	2 ½"
2,500,000	3"	2 ½"
3,000,000	4"	3"
3,500,000	4"	3"
4,000,000	4"	3"
Input Btu/Hr	200-300 FT*	
	NAT.	L.P.
2,000,000	3"	2 ½"
2,500,000	4"	3"
3,000,000	4"	3"
3,500,000	4"	3"
4,000,000	4"	3"

6. VENTING

Appliances for outdoor installation are intended to vent using a listed vent cap.

For indoor installations venting must be in accordance with Part 7, Venting of Equipment, of the current National Fuel Gas Code, ANSI Z223.1, or Section 7, Venting of Equipment and Air Supply for Appliances, of the current CAN/CGA B149, Installation Codes, and applicable provisions of the local building codes.

Vent connectors serving appliances vented by natural draft shall not be connected into any portion of mechanical draft systems operating under positive pressure.

Horizontal runs of vent pipe shall be securely supported (approximately every 4 feet) to prevent sagging and maintain a minimum upward slope of 1/4" per foot from the appliance to the vent terminal.

When an existing appliance is removed from a common venting system, the common venting system is likely to be too large for proper venting of the appliances remaining connected to it. At the time of removal of an existing appliance, the following steps must be followed with each appliance remaining connected to the common venting system placed in operation, while the other appliances remaining connected to the common venting system are not in operation.

- a) Seal any unused openings in the common venting system.
- b) Visually inspect the venting system for proper size and horizontal pitch and determine that there is no blockage, restriction, leakage, corrosion or other deficiency, which could cause an unsafe condition.
- c) Insofar as is practical, close all building doors and windows and all doors between the space in which the appliances remaining connected to the common venting system are located and other spaces of the building. Turn on the clothes dryers and any appliances not connected to the common venting system. Turn on any exhaust fans, such as range hoods and bathroom exhausts, so they will operate at maximum speed, do not operate a summer exhaust fan. Close fireplace dampers.

- d) Place in operation the appliance being inspected. Follow the lighting instructions. Adjust thermostat so that appliance operates continuously.
- e) Test for spillage at the draft control device relief opening after 5 minutes of main burner operation. Use the flame of a match or candle or smoke from a cigarette.
- f) After it has been determined that each appliance remaining connected to the common venting system properly vents when tested as outlined above, return doors, windows, exhaust fans, fireplace dampers and any other gas-burning appliance to their previous condition of use.
- g) Any improper operation of the common venting system must be corrected so that the installation conforms to the current National Fuel Gas Code, ANSI Z223.1 or the current CAN/CGA B149, Installation Codes. When resizing any portion of the common venting system, the common venting system should be resized to approach the minimum size as determined using the appropriate tables in Part 11 of the current National Fuel Gas Code, ANSI Z223, 1 or the current CAN/CGA B149, Installation Codes.

Hydronic heating heat exchanger surfaces and vent piping should be checked at least yearly for deterioration and carbon deposits. Domestic hot water heat exchanger surfaces and vent piping should be checked every 6 (six) months. Remove all soot or other obstructions from the chimney and flue, which might impede draft action. Replace any damaged or deteriorated parts of the venting system.

A qualified service technician should follow this procedure when inspecting and cleaning the heat exchanger and vent pipe.

1. Turn off electrical power and close main manual gas shut-off and allow appliance to cool down
2. Remove the vent pipe running to chimney. Remove top outer panel and flue collector access panel. Check heat exchanger, vent and chimney for obstruction and clean as necessary.

3. Remove burner from appliance and vacuum the burner, and the heat exchanger. If heat exchanger is excessively dirty it may be necessary to remove it from the appliance and wash it down with proper detergent cleaner. Be aware that the combustion chamber base is insulated with ½" thick ceramic blanket. If this material is damaged or displaced it must be replaced before starting up the appliance.
4. Reinstall parts removed in steps 2 and 3. Be sure that vent pipe has proper pitch and is properly sealed. Repair or replace any gaskets, which may have been damaged in steps 2 and 3.
5. **CAUTION:** When replacing the burner be careful to fully engage the back of the burner box into the retaining slot in the combustion chamber base. Failure to properly locate the burner will result in erratic flame operation with the possibility of delayed ignition on light off. Once in place make sure that the burner box is sealed against the seal gasket provided at the mixing tube.
6. Restore electrical power and gas supply to the appliance.
7. Place appliance in operation using lighting instructions provided.
8. While the appliance is operating, check for flue gas leaks and proper vent operation. Seal any flue gas leaks using appropriate gasket or sealing material. Carefully examine the flue collector access panel and heat exchanger ends.

The MicoFlame Grande is category 1, 85% efficient when supplied as a non-condensing appliance. When supplied with the optional condensing cartridge, the MicoFlame Grande is 95% efficient and is considered to be a category II or IV appliance. Three venting options are available for this appliance in both condensing and non-condensing configurations. See Figure 2 for details. (Please refer to Table 2 for vent dimensions)

Figure 2 – Venting Arrangement

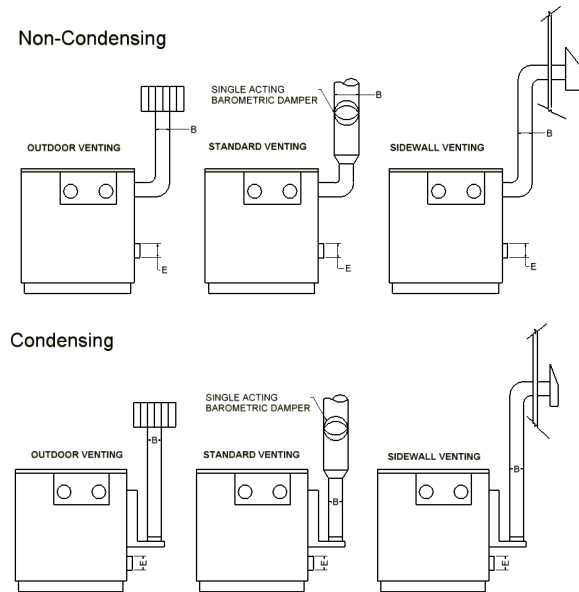

6.1 OUTDOOR VENTING

When fitted with the factory supplied rain shields and UL approved vent cap, the MicoFlame Grande is self-venting. The following applies to outdoor installations:

1. Use only factory supplied rain shields.
2. Periodically check to ensure that air intake and vent cap are not obstructed.
3. Locate appliance at least 3 feet away from any overhang.
4. Locate appliance at least ten feet from building air intake.
5. Avoid installation in areas where runoff from adjacent building can spill onto appliance.

6.2 STANDARD VENTING

The MicoFlame Grande is a category I appliance and is approved for venting into a common chimney provided it is in good condition and meeting the local Codes. Typically, the chimney will be 'B' vent or brick with clay or metal liner. If the chimney height is much greater than 30 feet or if drafts are in excess of negative 0.05" W.C., it may be beneficial to provide a single acting barometric damper directly above the vent collar. This damper will ensure smooth light off and minimize standby loss through the appliance. Be sure to position the damper at least 6" away from the wall of the vent connector.

6.3 SIDEWALL VENTING

When fitted with the factory supplied vent terminal, the MicoFlame Grande can vent up to 60 equivalent feet. Elbows can range from 8 to 15 feet in equivalent length depending on centreline radius. See Table 2 for vent sizes.

Appliances may be installed with either a horizontal sidewall vent or vertical roof top terminal. Terminals differ with each application. Horizontal lengths over 5 feet must be installed using corrosion resistant stainless steel. Use single wall vent and seal all joints or use pressure rated double wall vent.

Refer to local codes for proper installation and location of vent terminals.

When using sidewall vent, all vent connector seams and joints must be sealed with pressure sensitive aluminium tape or silicone sealant as specified by the vent manufacturer. Aluminium tape must meet the provisions of SMACNA AFTS-100-73 Standard.

When venting through unheated spaces with single wall vent, insulation must be properly wrapped around the vent pipe to prevent flue gas condensation inside the vent.

Periodically check to ensure that the vent terminal is unobstructed.

6.4 OUTDOOR AIR KIT

When fitted with the factory supplied air inlet ring and air intake terminal, the MicoFlame Grande can draw outdoor air over an equivalent length of 60 feet. See Table 2 for vent sizes.

Appliances may be installed with either a horizontal sidewall vent or vertical roof top terminal. Terminals differ with each application.

The following applies to outdoor air installations:

1. Use only factory supplied air intake terminal.
2. Periodically check to ensure that air intake is not obstructed.
3. Refer to local codes for proper installation and location of vent terminals. Vertical vent terminal must be at least 3 feet above the highest point where it is located above the roof of a building
4. Locate the air intake at least five feet away from the vent discharge. For sidewall venting locate the air intake below the vent outlet if possible.

6.5 FILTER KIT

A slot at the bottom of the rear panel is the standard air inlet configuration for the MicoFlame Grande. As an option, outside air could be introduced directly through the back or top panels. A filter kit is available. The filter is washable and accounts for an additional pressure loss of less than 0.05" W.C. Highly recommended for dusty environments. The filter kit can also be provided when using the outdoor air kit.

6.6 CONDENSER HEAT RECOVERY MODULE (CHRM)

The MicoFlame Grande All Stainless Steel CHRM is mounted in a stainless steel inner jacket chamber at the back of the appliance. The CHRM is constructed from all stainless steel headers and special multiple horizontal stainless tubes. This CHRM is designed to maximize heat transfer efficiency by fully condensing flue products and is suitable to resist the low PH of condensate.

The CHRM must be supplied with adequate water flow at all times during operation. Do not operate the appliance with the CHRM piped out or isolated.

The CHRM is mounted in the discharge of the flue products from the primary heat exchanger. This allows additional heat to be absorbed from the flue products exhausted from the combustion process. If isolation valves are provided on the CHRM, the provision of a relief valve at the outlet of the CHRM is recommended. This valve is to be sized at minimum for 10% of the input of the appliance and is to be piped to drain.

When cold water supply with temperatures less than 110°F (44°C) passes through the CHRM it will cool the flue products below dew points resulting in the formation of condensation. Furthermore, the volumetric flow rate of the flue gases will be reduced.

The appliance CHRM loop may be used in condensing mode for a variety of application including domestic hot water and hydronic space heating. Recommended piping arrangement is shown in Figure 3. Maximum capacity through the CHRM is summarized in Table 5; flows in excess of 60 GPM must be bypassed.

Figure 3 – Typical Condensing System

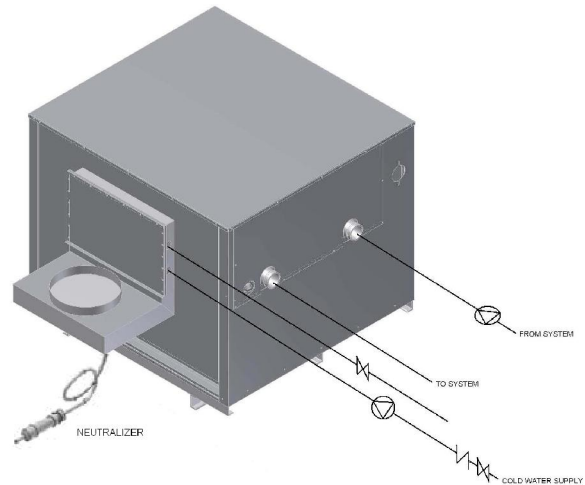

Condensate from the MicoFlame Grande must be treated before being discharged to drain. pH level of the condensate is to be checked regularly and the neutralizing medium is to be replaced as required. A neutralizing cartridge is available from the factory. The condensing MicoFlame Grande must be vented using only special venting type AL29-4C stainless steel or equivalent, please follow instructions detailed below.

When supplied with the CHRM, the MicoFlame Grande is 95% efficient (category II or IV appliance) which requires the use of a special venting system fabricated from AL29-4C or equivalent material. Only venting components listed by a nationally recognized testing agency may be used.

This appliance may be installed with conventional, sidewall or vertical venting. Conventional vented appliances operate with negative pressure in the vent pipe and require a special vent adapter to increase the flue outlet diameter. Sidewall and vertically vented appliances operate with positive pressure in the vent pipe and may be directly connected to the flue outlet without the use of an increaser. Consult the vent pipe manufacturer's instructions for minimum clearances to combustible material for vent components. In the absence of instructions, the minimum clearance to combustible material is six inches.

Consult vent pipe manufacturer's instructions for proper method of sealing vent pipe sections and fittings. In the absence of instructions, make sure that pipe and fittings are clean by swabbing with alcohol. Use Dow Corning 736 or 732 RTV, Polybar # 500 RTV or Sil-bond 4500 or 6500 to seal vent pipe. Do not use other sealants or adhesives except as expressly permitted by vent manufacturer's instructions.

Consult vent pipe manufacturer's instructions for vent system assembly. Follow vent pipe manufacturer's instructions if those instructions differ from this section.

Conventional Venting

Multiple appliances may be vented into a conventional chimney. The chimney must be lined with AL29-4C or equivalent and a single acting barometric damper must be provided for each appliance. Vent diameters are to be increased by one size over the recommended size downstream of the barometric damper.

A qualified professional using a proven vent-sizing program with input of accurate operating parameters must properly calculate sizing of the venting system. In applications where flue gas temperatures are lower than can support a Category II with conventional negative draft, it will be determined at the venting design stage that a positive pressure will be developed in the vent. It will then be necessary to either provide separate vents as for Category IV, to pressurize the boiler room, or to provide an extractor at the chimney outlet in order to maintain a negative draft in the chimney and allow common venting.

The chimney must be protected from down drafts, rain and debris by using a listed chimney cap. Approval of the installation will be at the discretion of authorities having jurisdiction.

Sidewall and Vertical Venting

The maximum vent length is 100 equivalent feet. Vent pipe may be run through a vertical or horizontal chase provided that minimum clearances to combustible materials are maintained. The vent should terminate a minimum 12 inches above grade plus normally expected snow accumulation, or 7 feet above grade if located adjacent to public walkways. Do not install over public walkway where local experience indicates condensation or vapour from the boiler creates a nuisance or hazard.

Minimum 3 feet above any forced air inlet located within 10 feet of vent termination. Minimum 4 feet below, 4 feet horizontally or above any door window or gravity air inlet. Minimum 4 feet horizontally from electric meters, gas meters, regulators and relief valves. Use appropriately designed thimbles when passing through combustible walls or roofs. Install fire stops where vent passes through floors, ceilings or framed walls. The fire stop must close the opening between the vent pipe and the structure. Locate vent terminal above combustion air intake terminal (if used) and no closer than 2 feet vertically or horizontally. Vertical venting requires flashing and a storm collar to prevent moisture from entering the structure. Vertical vent termination must be at least 2 feet plus the expected snow accumulation above the roof penetration height.

Figure 4 – Secondary Heat Exchanger

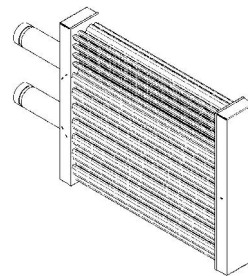

Table 5 – CHRMs Head Loss & Flow for 10°F Rise

Model	US GPM	ΔP - Ft.
2000	40.0	5.5
2500	50.0	8.0
3000	60.0	11.5
3500	40.0*	8.5
4000	46.0*	11.0

*Flow for 15°F rise at high fire

7 WATER PIPING

CAUTION

The MicoFlame Grande Series should be installed by qualified personnel.

Check all applicable local heating, plumbing and building safety codes before proceeding.

The circulating pump must be installed at the appliance inlet. Always pump toward the heat exchanger. Minimum operating system pressure when cold is to be 15 PSIG and when hot must not drop below 30 PSIG.

Improper piping of this appliance will void the manufacturer's warranty. Improper piping arrangement may cause heat exchanger tube failure resulting in flooding and extensive property damage. Excessive water hardness causing scaling in the copper heat exchanger tubes is not covered under the manufacturer's warranty. Excessive pitting and erosion of the internal surface of the copper heat exchanger tubes due to high water velocity or chemicals is not covered under the manufacturer's warranty. Improper operation of this appliance by permitting return water temperature below 115°F will result in flue gas condensation leading to corrosion deposits on the heat exchanger tubes and will void the warranty.

To eliminate trapped air, install venting devices at high points in the system as well as in the piping on the suction of the pump and in the piping on the discharge of the appliance.

Suitable pipe hangers or floor stands must support the weight of all water and gas piping.

The appliance must be installed so that the gas ignition system components are protected from water (dripping, spraying, rain, etc.) during appliance operation and service (circulator replacement, control replacement, etc.)

Shut off valves must be installed at the inlet and outlet connections of the appliance to provide for isolation of the heat exchanger for servicing. If the appliance is installed above radiation level, it must be provided with a low water cutoff device at the time of appliance installation.

This appliance is of a low mass design, which provides for instant heat transfer. Special attention to water flow rates will ensure that temperature rise does not exceed 35 °F (19.4 °C).

The following Table 6 is provided as a guide. For application in areas known to have hard water conditions, or for soft water contact factory for recommendations.

Table 6 – Flow vs. Head Loss for Various Temperature Rise

20 °F		
Model	USGPM	ΔP ft.
2000	170	5.1
2500	200*	8.2
3000	200*	8.2
3500	200*	10.2
4000	200*	10.2
30 °F		
Model	USGPM	ΔP ft.
2000	113	2.4
2500	141	4.3
3000	170	6.2
3500	198	10.2
4000	200*	10.2
35 °F		
Model	USGPM	ΔP ft.
2000	97.0	1.8
2500	121.0	3.3
3000	146.0	4.5
3500	170.0	7.7
4000	194.0	9.8

* Maximum flow recommended. Temperature rise will be exceeded. CuNi heat exchanger should be considered for flow rates exceeding maximum recommended flows.

7.1 PROTECTION DEVICES

PRESSURE RELIEF VALVE (shipped loose)

This appliance is supplied with a relief valve sized in accordance with ASME Boiler and Pressure Vessel Code, Section IV ("Heating Boilers"). The relief valve is to be installed in the vertical position and mounted in the hot water outlet. No valve is to be placed between the relief valve, and the appliance. To prevent water damage, the discharge from the relief valve shall be piped to a suitable floor drain for disposal when relief occurs. No reducing couplings or other restrictions shall be installed in the discharge line. The discharge line shall allow complete drainage of the valve and line. Relief valves should be manually operated at least once a year.

CAUTION

Avoid contact with hot discharge water

LOW WATER CUT-OFF (if equipped)

If this boiler is installed above radiation level, a low water cut-off device must be installed at the time of boiler installation. Some local codes require the installation of a low water cut-off on all systems. Electronic low water cut-offs are available as a factory supplied option on all models. Low water cut-offs should be tested at least yearly. The normally open switch contact of the low water cutoff is to be wired in series with the flow switch. A diagnostic light will be indicated on the control display on a low flow condition.

CAUTION
Remove jumper between H & P1 when connecting to 24 VAC circuit.

Figure 5 – Low Water Cutoff Electrical Connections

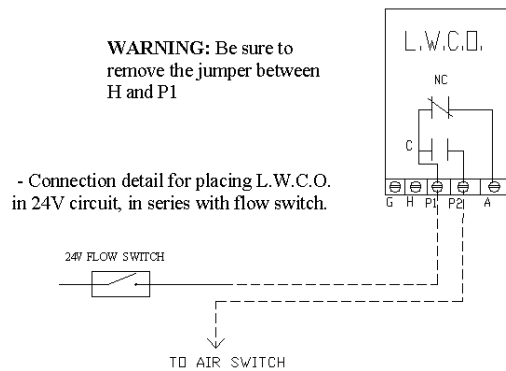

FLOW SWITCH (shipped loose)

A water flow switch is shipped loose and is to be installed in the outlet piping on all heating boilers and hot water supply boilers. The flow switch is wired in series with the 24VAC safety control circuit. A diagnostic light will be indicated on the control display on a low flow condition.

7.2 FREEZE PROTECTION

- Appliance installations are not recommended outdoors or in areas where danger of freezing exists unless precautions are taken. Maintaining a mixture of 50% water and 50% propylene glycol is the preferred method of freeze protection in hydronic systems. This mixture will protect the appliance to approximately -35°F (-37°C). To maintain the same temperature rise across the appliance increase the GPM flow by 15% and the head loss by 20%.

The following example demonstrates the procedure to follow for calculating the revised head for the heat exchanger when using a water / glycol mixture.

- Given that Camus is showing a heat exchanger flow and head loss of 100 gpm @ 10 feet
- Increasing the flow by 15% now results in a head loss of 13 feet at 115 gpm (from B&G system syzer). At this increased flow Camus now recommends to increase the head loss by 20%.
- The requirement for the heat exchanger with water / glycol mixture will now be 115 gpm @ 15.6 feet. (ie. $1.2 \times 13\text{ft.} = 15.6 \text{ ft.}$)
- A similar procedure must be followed to calculate the additional head loss in pipe and fittings in order to arrive at the proper pump selection.

For Outdoor installations regular inspections should be made to ensure that air intake and vent are clear. Always consider the use of a shelter such as a garden shed in lieu of direct exposure of the appliance to the elements. The additional protection afforded by the shelter will help to minimize nuisance problems with electrical connections and will allow easier servicing of the appliance under severe weather conditions.

7.3 CHILLED WATER SYSTEMS

When an appliance is connected to an air conditioning system where the same water is used for heating and cooling, the chiller must be piped in parallel with the appliance. Appropriate flow control valves; manual or motorized must be provided to prevent the chilled water from entering the appliance. (See figure 6)

Figure 6 – Typical Chilled Water System

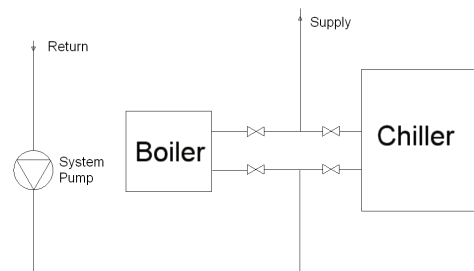

When an appliance is connected to heating coils located in air handling units (where they

may be exposed to refrigerated air circulation), the appliance piping system shall be equipped with a flow control valve or other automatic means to prevent gravity circulation of chilled water through the appliance. Chilled water in the appliance will create condensate on the appliance tubes, which will collect in the combustion chamber causing corrosion.

7.4 HEATING SYSTEM PIPING

In larger systems, it is advisable to connect the appliance to the piping employing the primary-secondary pumping system. This system is used to provide system advantages that would not be available with a single pumping system. Primary-secondary pumping is illustrated in Figure 7.

The following are some advantages of the primary-secondary pumping system:

- Greatly reduce the stand by losses through the appliance
- Minimize heat exchanger wear.
- Reduce power consumption

7.5 LOW WATER TEMPERATURE SYSTEMS

In applications where the heating system requires supply water temperatures below 115°F, a recirculation line must be installed upstream of the appliance pump so that outlet water can be re-circulated to raise the inlet temp to a minimum of 115 °F. Balancing valves, preferably globe valves are used to adjust flow. (See figure 8)

- Adjustment procedure.
 - a. Fully open bypass and outlet valves.
 - b. With appliance running, read inlet temperature after 15 minutes.
 - c. If the inlet temperature is less than 115°F slowly close outlet valve until the inlet temperature climbs to 115°F
 - d. If the inlet temperature is greater than 115°F but not greater than

140°F no further adjustment is required.

- e. Check the inlet temperature after 5 minutes and make final adjustments.

7.6 INSTANTANEOUS WATER HEATER

An instantaneous appliance is designed to deliver hot water without the use of a storage tank. It is suitable for applications with variable load such as restaurants, condominiums, apartments and motels. (See figure 9) Call manufacturer for recommendations.

7.7 HOT WATER SYSTEM PIPING

Piping and components connected to the appliance must be suitable for use with potable water. The appliance should not be connected to any heating system piping or components previously used with non-potable water. Hot water storage tanks used in potable water system must be equipped with temperature and pressure relief valve. Figure 10 and 11 illustrates typical water heating piping arrangement for single appliance and multiple appliances.

The storage tanks must be located as close as possible to the appliance to prevent excessive pressure drop. The required flow through the appliance is based on normal water hardness. Water hardness above normal levels will require higher flow rates to prevent scaling and Copper Nickel heat exchanger tubes to prevent erosion. Choose a pump for the local water hardness conditions. Alternatively soften the water to normal hardness level.

The appliance could be fitted with an economizer (secondary heat exchanger) to achieve nominal efficiency of 95%. This heat exchanger is fabricated from stainless steel and can accept inlet water temperature as low as 40°F.

Figure 7 – Typical Heating System

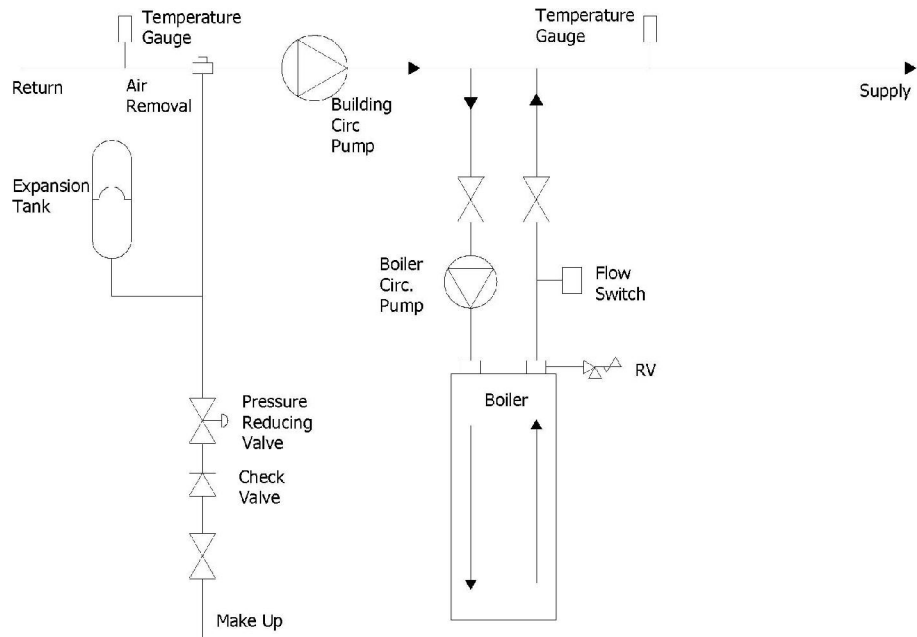

Figure 8 – Typical Low Water Temperature System

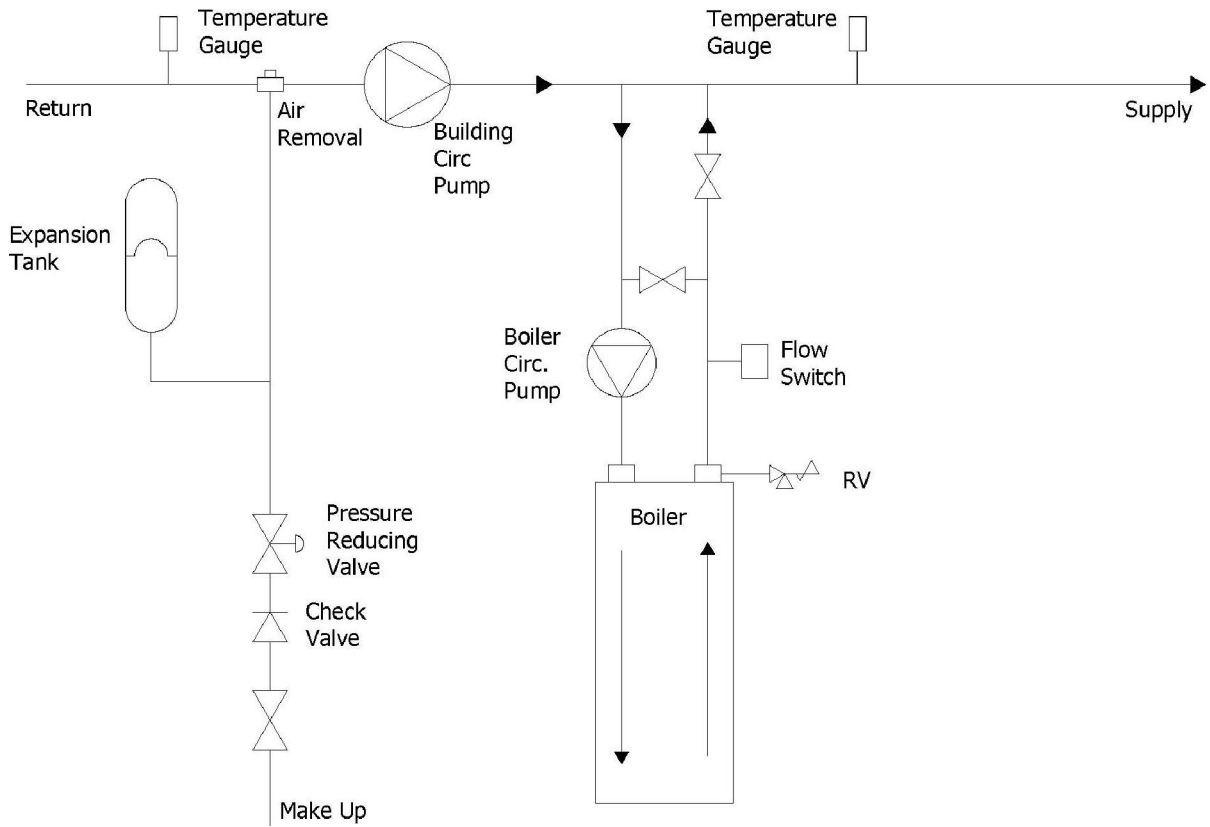

Figure 9 – Typical Instantaneous Water System

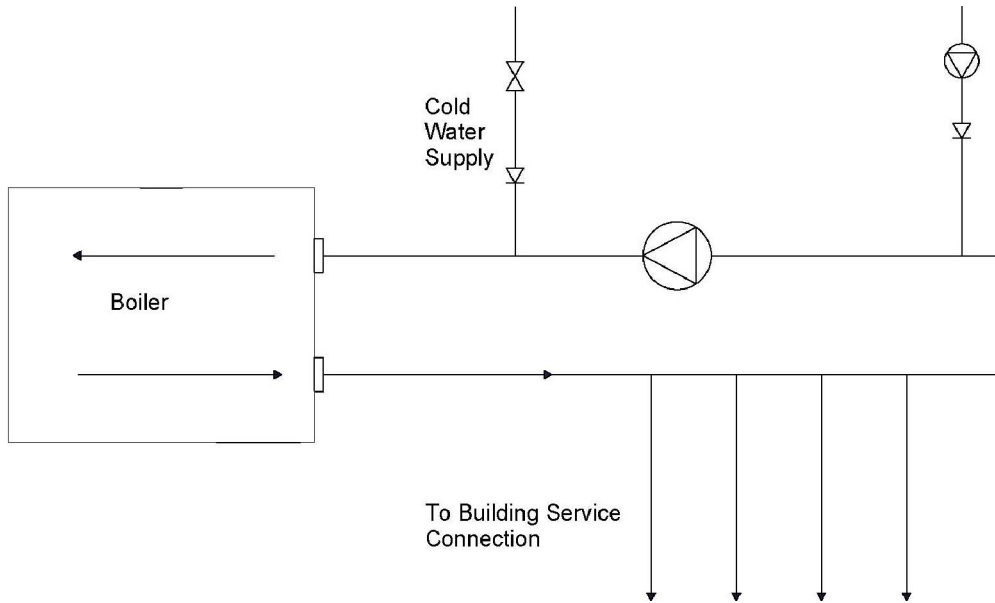

Figure 10 – Typical Water Heating System

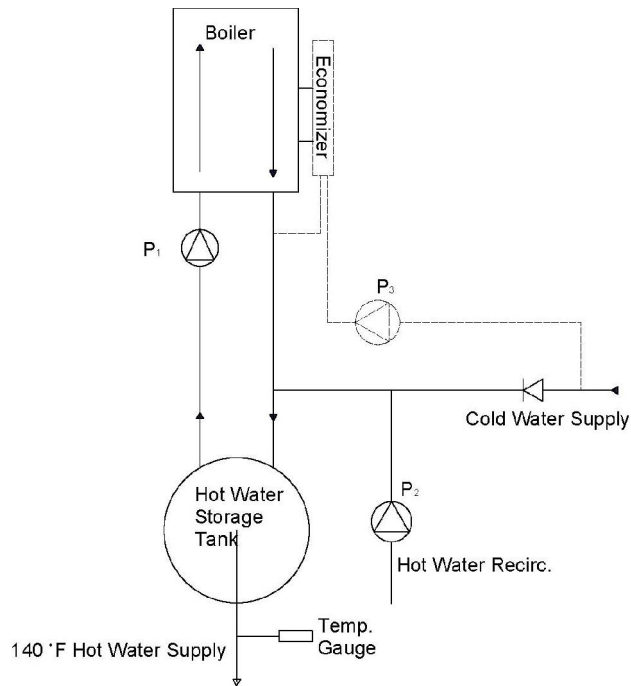
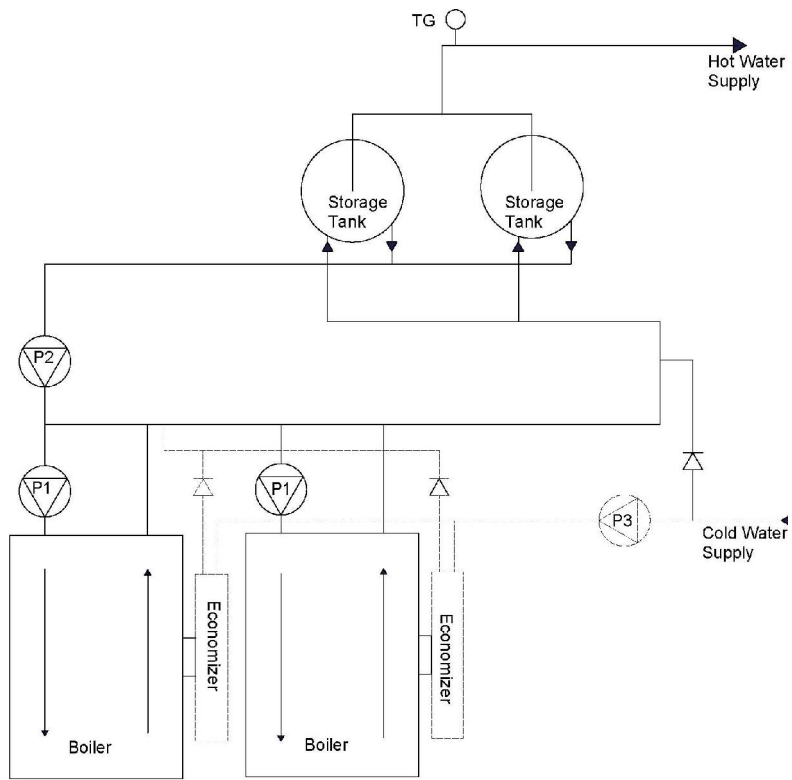

Figure 11 – Typical Water Heating System



8 INSTRUMENTATION AND CONTROLS

The appliance is equipped with safety controls as well as operational controls.

8.1 SAFETY CONTROLS

High Temperature Limit

The high temperature limit is located behind the appliance's access doors. A remote capillary bulb runs to a thermo-well on the outlet side of the inlet/outlet header. The appliance high limit is set at the factory to 210°F for hot water and 230°F for heating.

Air Flow Switch

A differential air pressure switch is provided to prove the operation of the fan and adequate air flow to the burner. The pressure switch sensing point is at the inlet to the mixing tube where the air and gas mixes. The LED indicator for air flow will not illuminate should the pressure switch detect a sustained low air condition. The appliance is provided with one air switch per burner module.

8.2 CONTROL PANEL

The appliance is provided with a control panel at the front. Operating controls are installed inside the control box and are accessible by undoing the thumb screw and opening the door. The diagnostic information centre as well as the on/off switch, 24V fuse, and the appliance temperature controls reside on the control box door.

Figure 12 – Display, Appliance Temperature Controller and Indicating LED

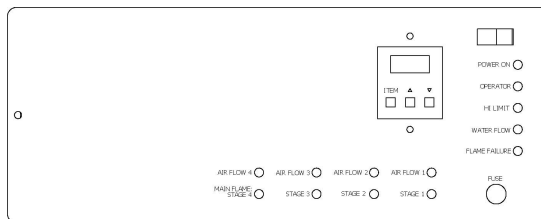

The Boiler Temperature Controller (BTC) for this appliance is a Camus 780014 SmartFlame control. This controller accommodates up to four-stage control with six modes of operation which provides setpoint as well as rest control. It provides the following:

1. Readings of inlet and outlet water temperatures as well as ΔT temperature rise.
2. Six pre-set modes of operation; mode 1, 2, 4, and 5 for heating, mode 3 for DHW and mode 6 for operation by a remote controller.
3. Operation as an auto reset limit.

4. Operation as a control for inlet water temperature.
5. Optional tank mounted sensor used in conjunction with inlet sensor.
6. Adjustable pump delay feature based on ΔT temperature difference between inlet and outlet temperatures. Accepts 1/6 hp. pump directly across terminals 13 & 14.
7. Adjustable; target temp, inter-stage differential, on delay between stages, minimum on time per stage, minimum off time per stage.
8. Display of run hours for maintenance purposes. Counter wraps around at 1000 hours.
9. Flame failure signal 24 V.
10. Molex connector for ease of service.
11. Error message display.
12. Test override feature to test pump operation, stages 1, 2, 3, 4, and 5 and alarm.
13. Pump exercising feature runs pump 10 seconds every three days of no pump operation.

Setting the Appliance Temperature Control

Press and hold the ITEM, UP and DOWN buttons simultaneously for 1 second. The appliance will shut down and pressing the ITEM key and then selecting the desired setting using the UP, DOWN buttons, can now make the settings. Pressing the ITEM key again will cause the last setting to be accepted. Once all settings have been made wait for 30 seconds for the control to return to normal operating mode. In normal operating mode the inlet temperature, outlet temperature, ΔT temperature and ON hours can be viewed by repeatedly pressing the ITEM key only. If you wish to check the setting you will have to start again by pressing and holding the ITEM, UP and DOWN buttons simultaneously for 1 second, and then use only the ITEM key to scroll through the settings. After checking the settings allow the control to return to normal operation on its own.

Mode 1 is intended for hydronic heating. The set-point for inlet water control is pre-set to 180°F and the auto re-set limit is set to 230°F. The inlet set-point can be adjusted, however the limit is fixed. In addition to the auto reset limit the factory installs a manual re-set limit set to 250°F. The control turns on the appliance pump and

stages the appliance to maintain set-point target temperature at the **appliance inlet** temperature whenever an external heat demand is present. Once the external heat demand is removed, the control turns off the appliance and operates the appliance pump based on the purge feature

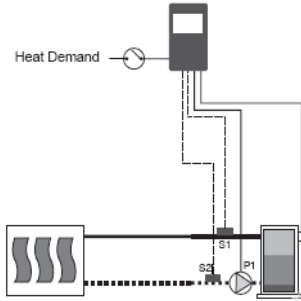

Mode 2 is intended for hydronic heating. The set-point for inlet water control is pre-set to 180°F and the auto re-set limit is set to 230°F. The inlet set-point can be adjusted, however the limit is fixed. In addition to the auto reset limit the factory installs a manual re-set limit set to 250°F. The control turns on the appliance pump and stages the appliance to maintain set-point target temperature at the appliance inlet temperature whenever an external heat demand is present. Once the external heat demand is removed, the control turns off the appliance and operates the appliance pump based on the purge feature. The control turns on the appliance pump and stages the appliance to the set-point target temperature at the **system** temperature whenever an external heat demand is present. Once the last appliance stage turns off and the heat demand is still present, the control then operates the appliance pump based on the purge feature. In this case, it is imperative that the system pump operates continuously in order to provide constant circulation past the system sensor. The appliance pump then turns back on with the first stage of the appliance. If the heat demand is removed, the appliance is turned off and the control operates the appliance pump P1 based on the purge feature.

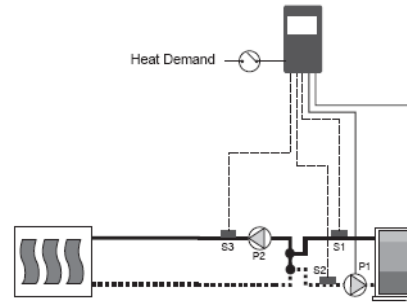

Mode 3 is intended for domestic water heating. The set-point for inlet water control is pre-set to 140°F and the auto re-set limit is set to 200°F. The inlet set-point can be adjusted, however the limit is fixed. In addition to the auto reset limit the factory installs a manual re-set limit set to 210°F. The control turns on the appliance pump and stages the appliance to maintain set-point target temperature at the **appliance inlet** temperature. An internal demand is generated from the DHW sensor which could be placed in the storage tank while the external heat demand is permanently wired or through a timer. Once the DHW tank is satisfied (internal demand is removed), the control turns off the appliance and operates the appliance pump based on the purge feature.

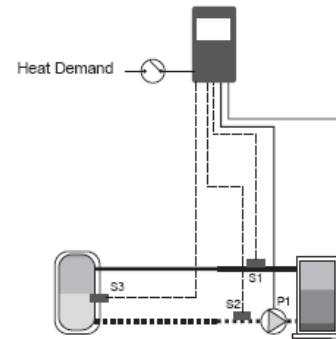

Mode 4 is intended for hydronic heating. The set-point for inlet water control is pre-set to 180°F and the auto re-set limit is set to 230°F. The inlet set-point can be adjusted, however the limit is fixed. In addition to the auto reset limit the factory installs a manual re-set limit set to 250°F. The control turns on the appliance pump and stages the appliance to maintain outdoor reset

target temperature at the **appliance** inlet temperature whenever an external heat demand is present. Once the external heat demand is removed, the control turns off the appliance and operates the appliance pump based on the purge feature.

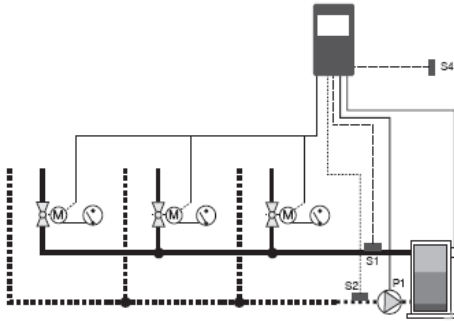

Mode 5 is intended for hydronic heating. The set-point for inlet water control is pre-set to 180°F and the auto re-set limit is set to 230°F. The inlet set-point can be adjusted, however the limit is fixed. In addition to the auto reset limit the factory installs a manual re-set limit set to 250°F. The control turns on the appliance pump and stages the appliance to maintain outdoor reset target temperature at the **system** temperature whenever an external heat demand is present. Once the last appliance stage turns off and the heat demand is still present, the control then operates the appliance pump based on the purge feature. In this case, it is imperative that the system pump operates continuously in order to provide constant circulation past the system sensor. The appliance pump then turns back on with the first stage of the appliance. If the heat demand is removed, the appliance is turned off and the control operates the appliance pump based on the purge feature.

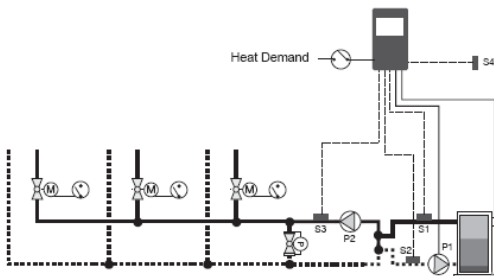

Mode 6 is intended for multiple appliance application and all stages are closed at all times. In essence there is no operator at the appliance. A removable jumper is provided in the electrical enclosure across the contacts to be used for connection to the remote operator. The fixed

auto re-set limit is set to 230°F. In addition to the auto reset limit the factory installs a manual re-set limit set to 250°F. The control provides pump operation. Staging operation is provided by an external sequencing control. Heat demand provided via external analog input signal from Tekmar sequencing control (275). The control turns on the boiler pump and adjusts the number of stages being fired in proportion to the analog input signal. Note: Existing Tekmar sequencing control (264, 268) can be used to control the boiler staging. In this case, the BTC turns on the boiler pump and Stage 1 when an external heat demand is present. Stage 2, 3, and 4 are controlled by the sequencing control. Each control turns on its respective appliance pump and stage 1 contact whenever an external heat demand is present. Once the external heat demand is removed from the control, the control turns off the stage 1 contact and operates the pump to provide purging. Once the purge period is complete, the control turns off the appliance pump.

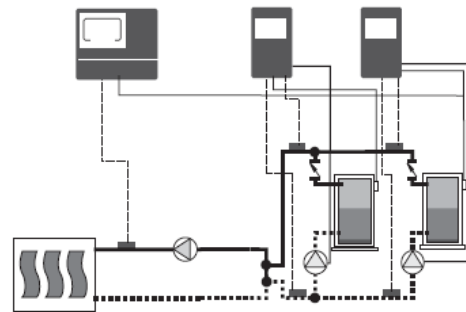

If this setting is inadvertently chosen the appliance will cycle on the limits. There is a danger of scalding if this setting is used in a DHW application.

Mode 7 A removable jumper is provided in the electrical enclosure across the contacts to be used for connection to the remote operator. Heat demand provided via external analog input signal from EMS or tN4 system control (e.g. 420). The control turns on the boiler pump and operates the boiler to maintain the boiler target at the boiler **inlet** sensor whenever a heat demand is present. Once the external heat demand is removed from the control, the control turns off the stage 1 contact and operates the pump to provide purging. Once the purge period is complete, the control turns off the appliance pump.

Mode 8 A removable jumper is provided in the electrical enclosure across the contacts to be used for connection to the remote operator. Heat demand provided via external analog input signal from EMS or tN4 system control (e.g. 420). The control turns on the boiler pump and operates the boiler to maintain the boiler target at the **system** sensor whenever a heat demand

is present. Once the external heat demand is removed from the control, the control turns off the stage 1 contact and operates the pump to provide purging. Once the purge period is complete, the control turns off the appliance pump.

Figure 13 – Components and Auxiliary Control Connections

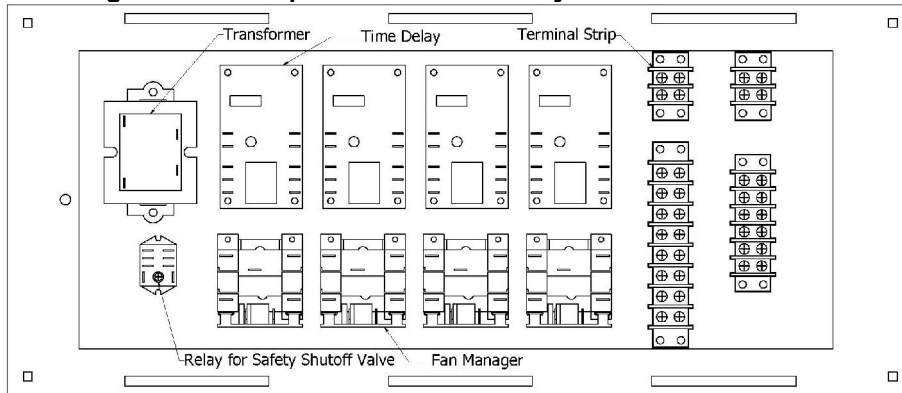

8.3 CONTROL DEVICES

Ignition Module

There is one ignition module provided per burner. The ignition module is mounted on a rail just behind the outer jacket front access door. The ignition module provide ignition sequence, flame monitoring and safety shutoff for the pilot.

Fan Manager

There is one fan manager provided in the control box per fan. The fan manager provides start and stop time delay for pre-purge and post-purge duties.

8.4 MODE 1 & 2: SETPOINT OPERATION: VIEW DISPLAY

From the Home display;



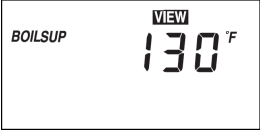
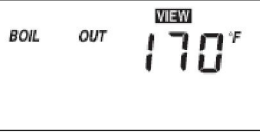
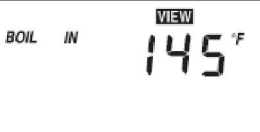
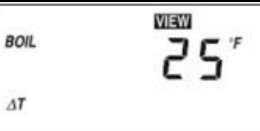
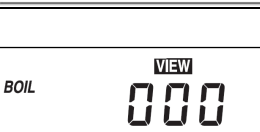

- 1) Press [ITEM] to view the following parameters:

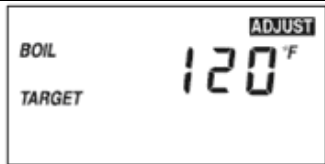
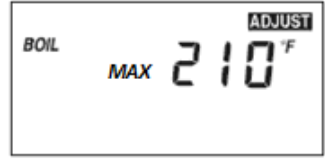
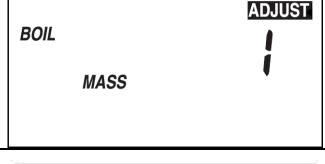

Display	Parameter Name	Parameter Description	Parameter Range
	Boiler System Temperature (Mode 2 ONLY)	Real-time System Temperature to Boiler	14 to 266°F (-10 to 130°C)
	Boiler Outlet Temperature	Real-time Outlet Temperature to Boiler	14 to 266°F (-10 to 130°C)
	Boiler Inlet Temperature	Real-time Inlet Temperature to Boiler	14 to 266°F (-10 to 130°C)
	Boiler Delta T	Real-time temperature difference between the outlet sensor and the inlet sensor.	-99 to 252°F (-72 to 140°C)
	Total Run Time Since Installation	Monitors the amount of operational time since the unit was installed. The two digits are the thousands of hours and the three digit display shows the hundreds of hours. Press (▲, ▼) simultaneously to reset the counter	Alternates between 00 and 999

8.5 MODE 1 & 2: SETPOINT OPERATION: ADJUST DISPLAY

From the Home display;

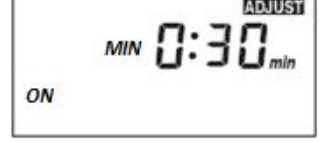
- 1) Press (Item, ▲, ▼) simultaneously to view the following parameters:



Display	Parameter Name	Parameter Description	Parameter Range
 The display shows the word "MODE" on the left and a large digit "1" in the center. A small "ADJUST" label is in the top right corner.	Mode	Operating mode for the boiler. NOTE: A complete description of each mode can be found in section 8.4 Modes of Operation in this manual.	1 to 8 Default = 1
 The display shows "BOIL" and "TARGET" on the left. A large "120" is in the center with a small "°F" to its right. A small "ADJUST" label is in the top right corner.	Boiler Target Temperature	To provide a target setpoint for the heating system. Setpoint is controlled to the inlet sensor	70 to 220°F (21 to 104°C) Default = 120°F (49°C)
 The display shows "BOIL" and "MAX" on the left. A large "210" is in the center with a small "°F" to its right. A small "ADJUST" label is in the top right corner.	Boil Max	Maximum boiler target temperature	120 to 225°F (48 to 107°C) Default = 210°F (99°C)
 The display shows "BOIL" and "MASS" on the left. A large digit "1" is in the center. A small "ADJUST" label is in the top right corner.	Boil Mass (Mode 2 ONLY)	Thermal mass of boiler. This determines interstage delay and minimum on and minimum off times.	1 to 3 Default = 1
 The display shows "DIFF" on the left. A large "10" is in the center with a small "°F" to its right. A small "ADJUST" label is in the top right corner.	Differential Temperature	To start the boiler below the Boiler Target temperature. For example, if the value is 10°F and the Boiler Target is 160°F the boiler will begin to modulate at 150°F and shut off at 170°F.	Au, 2 to 42°F (Au, -17 to 6°C) Default = 10°F
 The display shows "DIFF" and "STG" on the left. A large "3" is in the center with a small "°F" to its right. A small "ADJUST" label is in the top right corner.	Stage Differential	Dictates the staging of the boiler and each stage is iterative. For example, if the value is 3°F. Stage 1 will be active 3°F below setpoint, Stage 1 & 2 will be active 6°F below setpoint.	Au, 2 to 42°F (Au, -17 to 6°C) Default = 10°F
 The display shows "ON" and "DLY" on the left. A large "1:00" is in the center with a small "min" to its right. A small "ADJUST" label is in the top right corner.	On Delay	Interstage delay to activate the next stage	0:10 to 8:00 minutes Default = 1:00 minute
 The display shows "ON" and "MIN" on the left. A large "0:30" is in the center with a small "min" to its right. A small "ADJUST" label is in the top right corner.	Minimum On Time	Minimum on time for each stage	0:10 to 5:00 minutes Default = 0:30 minute

	Minimum Off Time	Minimum off time for each stage	0:10 to 5:00 minutes Default = 0:50 minutes
	Pump Delay	Boiler post pump time after burner has shut off, in seconds.	OFF, 0:20 to 9:55 min, On Default = 1:00 min
	Temperature Units	Select the desired unit of measurement	°F, °C Default = °F

8.6 MODE 3: SETPOINT OPERATION: VIEW DISPLAY

From the Home display;

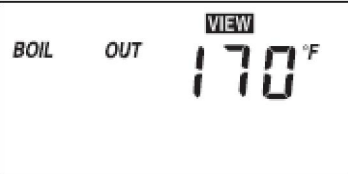
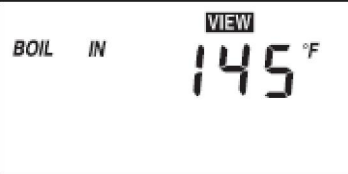

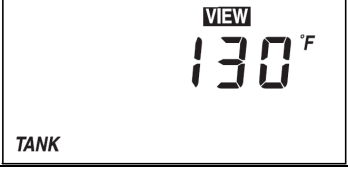
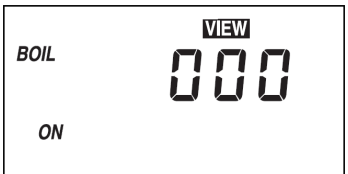





- 1) Press [ITEM] to view the following parameters:



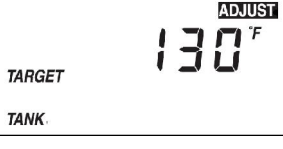

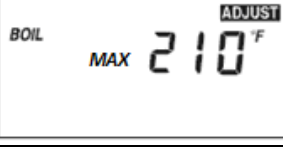
Display	Parameter Name	Parameter Description	Parameter Range
	Boiler Outlet Temperature	Real-time Outlet Temperature to Boiler	14 to 266°F (-10 to 130°C)
	Boiler Inlet Temperature	Real-time Inlet Temperature to Boiler	14 to 266°F (-10 to 130°C)
	Boiler Delta T	Real-time temperature difference between the outlet sensor and the inlet sensor.	-99 to 252°F (-72 to 140°C)
	Tank Temperature	Real-time Tank Temperature to Boiler	14 to 266°F (-10 to 130°C)
	Total Run Time Since Installation	Monitors the amount of operational time since the unit was installed. The two digits are the thousands of hours and the three digit display shows the hundreds of hours. Press (▲, ▼) simultaneously to reset the counter	Alternates between 00 and 999

8.7 MODE 3: SETPOINT OPERATION: ADJUST DISPLAY

From the Home display;

- 1) Press (Item, ▲, ▼) simultaneously to view the following parameters:



Display	Parameter Name	Parameter Description	Parameter Range
 The display shows the word "MODE" on the left and the number "3" in the center. Above the number is the word "ADJUST".	Mode	Operating mode for the boiler. NOTE: A complete description of each mode can be found in section 8.4 Modes of Operation in this manual.	1 to 8 Default = 1
 The display shows the word "BOIL" on the left and "TARGET" below it. In the center is "120" followed by a superscript "F". Above the number is the word "ADJUST".	Boiler Target Temperature	To provide a target setpoint for the heating system. Setpoint is controlled to the inlet sensor	OFF, 70 to 220°F (OFF, 21 to 104°C) Default = 140°F (82°C)
 The display shows the word "TARGET" on the left and "TANK" below it. In the center is "130" followed by a superscript "F". Above the number is the word "ADJUST".	Tank Target Temperature	To provide a target setpoint for the Tank. Setpoint is controlled to the Tank sensor	OFF, 70 to 190°F (OFF, 21 to 88°C) Default = 130°F (54°C)
 The display shows the word "DIFF" on the left and "TANK" below it. In the center is "3" followed by a superscript "F". Above the number is the word "ADJUST".	Tank Differential	To provide a modulation rate above and below the Tank Target Temperature. For example, if the value is 10°F and the Tank Target Temperature is 160°F the boiler will begin to modulate at 150°F and shut off at 170°F.	2 to 10°F (1 to 5°C) Default = 3°F (1°C)
 The display shows the word "BOIL" on the left and "MAX" below it. In the center is "210" followed by a superscript "F". Above the number is the word "ADJUST".	Boil Max	Maximum boiler target temperature	120 to 225°F (48 to 107°C) Default = 210°F (99°C)
 The display shows the word "DIFF" on the left. In the center is "10" followed by a superscript "F". Above the number is the word "ADJUST".	Differential Temperature	To start the boiler below the Boiler Target temperature. For example, if the value is 10°F and the Boiler Target is 160°F the boiler will begin to modulate at 150°F and shut off at 170°F.	Au, 2 to 42°F (Au, -17 to 5°C) Default = 10°F
 The display shows the word "DIFF" on the left and "STG" below it. In the center is "3" followed by a superscript "F". Above the number is the word "ADJUST".	Stage Differential	Dictates the staging of the boiler and each stage is iterative. For example, if the value is 3°F. Stage 1 will be active 3°F below setpoint, Stage 1 & 2 will be active 6°F below setpoint.	Au, 2 to 42°F (Au, -17 to 6°C) Default = 10°F
 The display shows the word "ON" on the left and "DLY" below it. In the center is "1:00" followed by "min". Above the number is the word "ADJUST".	On Delay	Interstage delay to activate the next stage	0:10 to 8:00 minutes Default = 1:00 minute

	Minimum On Time	Minimum on time for each stage	0:10 to 5:00 minutes Default = 0:30 minute
	Minimum Off Time	Minimum off time for each stage	0:10 to 5:00 minutes Default = 0:50 minutes
	Pump Delay	Boiler post pump time after burner has shut off, in seconds.	OFF, 0:20 to 9:55 min, On Default = 1:00 min
	Temperature Units	Select the desired unit of measurement	°F, °C Default = °F

8.8 MODE 4 & 5: OUTDOOR RESET OPERATION: VIEW DISPLAY

From the Home display;



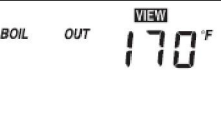
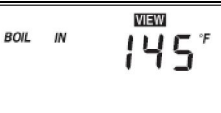
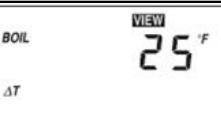
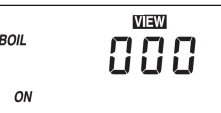

- 1) Press [ITEM] to view the following parameters:







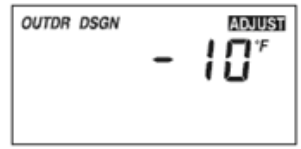
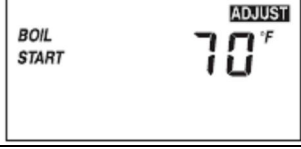

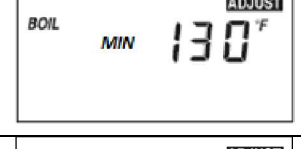
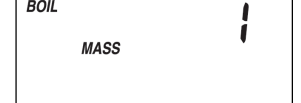
Display		Parameter Name	Parameter Description	Parameter Range
		Outdoor Temperature	Real-time Outdoor Temperature	-60 to 190°F (-51 to 88°C)
		Boiler System Temperature	Real-time System Temperature to Boiler (Mode 5 ONLY)	14 to 266°F (-10 to 130°C)
		Boiler Outlet Temperature	Real-time Outlet Temperature to Boiler	14 to 266°F (-10 to 130°C)
		Boiler Inlet Temperature	Real-time Inlet Temperature to Boiler	14 to 266°F (-10 to 130°C)
		Boiler Delta T	Real-time temperature difference between the outlet sensor and the inlet sensor.	-99 to 252°F (-72 to 140°C)
		Total Run Time Since Installation	Monitors the amount of operational time since the unit was installed. The two digits are the thousands of hours and the three digit display shows the hundreds of hours. Press (▲, ▼) simultaneously to reset the counter	Alternates between 00 and 999

8.9 MODE 4 & 5: OUTDOOR RESET OPERATION: ADJUST DISPLAY

From the Home display;

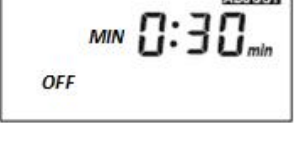
- 1) Press (Item, ▲, ▼) simultaneously to view the following parameters:

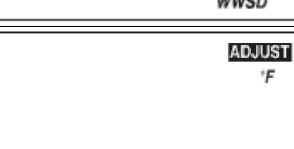

Display	Parameter Name	Parameter Description	Parameter Range
	Mode	Operating mode for the boiler. NOTE: A complete description of each mode can be found in section 8.4 Modes of Operation in this manual.	1 to 8 Default = 1
	Outdoor Start Temperature	Outdoor starting temperature used in the reset ratio for the heating system. Typically set to the desired building temperature.	35 to 85°F (2 to 29°C) Default = 60°F (21°C)
	Outdoor Design Temperature	Outdoor design temperature used in the reset ratio for the heating system. Set to the coldest annual outdoor temperature in the local area.	-60 to 50°F (-51 to 10°C) Default = -10°F (-23°C)
	Boiler Start Temperature	Starting water temperature used in the reset ratio calculation for the heating system. Typically set to the desired building temperature.	35 to 150°F (2 to 66°C) Default = 70°F (21°C)
	Boiler Design Temperature	Boiler design water temperature used in the reset ratio calculation for the heating system. Set to the boiler water temperature required to heat the building on the coldest annual outdoor temperature.	70 to 230°F (21 to 110°C) Default = 180°F (82°C)
	Boil Max	Maximum boiler target temperature	120 to 225°F (48 to 107°C) Default = 210°F (99°C)
	Boil Min	Minimum boiler target temperature	80 to 180°F (26 to 82°C) Default = 130°F (54°C)
	Boil Mass (Mode 5 ONLY)	Thermal mass of boiler. This determines interstage delay and minimum on and minimum off times.	1 to 3 Default = 1

	Differential Temperature	To provide a modulation rate above and below the Boiler Target temperature. For example, if the value is 10°F and the Boiler Target is 160°F the boiler will begin to modulate at 150°F and shut off at 170°F.	Au, 2 to 42°F (Au, -16 to 5°C) Default = 10°F
	Stage Differential	Dictates the staging of the boiler and each stage is iterative. For example, if the value is 3°F. Stage 1 will be active 3°F below setpoint, Stage 1 & 2 will be active 6°F below setpoint.	Au, 2 to 42°F (Au, -17 to 6°C) Default = 10°F
	On Delay	Interstage delay to activate the next stage	0:10 to 8:00 minutes Default = 1:00 minute
	Minimum On Time	Minimum on time for each stage	0:10 to 5:00 minutes Default = 0:30 minute
	Minimum Off Time	Minimum off time for each stage	0:10 to 5:00 minutes Default = 0:50 minutes
	Pump Delay	Boiler post pump time after burner has shut off, in seconds.	OFF, 0:20 to 9:55 min, On Default = 1:00 min
	Warm Weather Shutdown Temperature	Warm weather shutdown temperature using outdoor reset.	35 to 105°F, OFF (2 to 41°C, OFF) Default = 0:20 min
	Temperature Units	Select the desired unit of measurement	°F, °C Default = °F

8.10 MODE 6: OUTDOOR RESET OPERATION: VIEW DISPLAY

From the Home display;

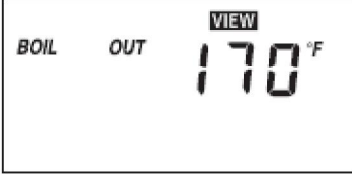
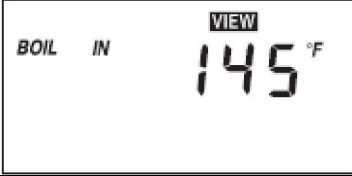
- 1) Press [ITEM] to view the following parameters:

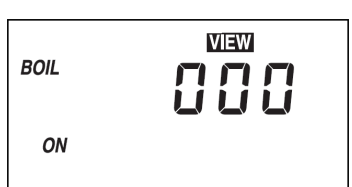
Display	Parameter Name	Parameter Description	Parameter Range
	Boiler Outlet Temperature	Real-time Outlet Temperature to Boiler	14 to 266°F (-10 to 130°C)
	Boiler Inlet Temperature	Real-time Inlet Temperature to Boiler	14 to 266°F (-10 to 130°C)
	Boiler Delta T	Real-time temperature difference between the outlet sensor and the inlet sensor.	-99 to 252°F (-72 to 140°C)
	Total Run Time Since Installation	Monitors the amount of operational time since the unit was installed. The two digits are the thousands of hours and the three digit display shows the hundreds of hours. Press (▲, ▼) simultaneously to reset the counter	Alternates between 00 and 999

8.11 MODE 6: OUTDOOR RESET OPERATION: ADJUST DISPLAY

From the Home display;

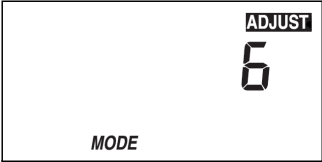
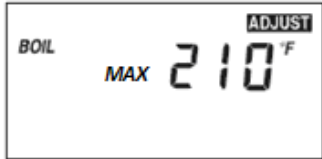
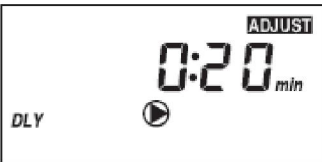
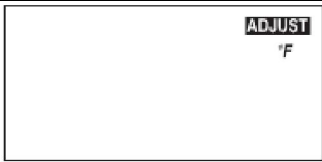

- 1) Press (Item, ▲, ▼) simultaneously to view the following parameters:

Display	Parameter Name	Parameter Description	Parameter Range
 The display shows the word "MODE" at the bottom left, a large number "6" in the center, and the word "ADJUST" in a small box at the top right.	Mode	Operating mode for the boiler. NOTE: A complete description of each mode can be found in section 8.4 Modes of Operation in this manual.	1 to 8 Default = 1
 The display shows "BOIL" on the left, "MAX" below it, a large "210" in the center, and "°F" on the right. "ADJUST" is in a small box at the top right.	Boil Max	Maximum boiler target temperature	120 to 225°F (48 to 107°C) Default = 210°F (99°C)
 The display shows "DLY" on the left, "0:20" in the center, and "min" on the right. "ADJUST" is in a small box at the top right.	Pump Delay	Boiler post pump time after burner has shut off, in seconds.	OFF, 0:20 to 9:55 min, On Default = 1:00 min
 The display shows "ADJUST" in a small box at the top right and "°F" in the center.	Temperature Units	Select the desired unit of measurement	°F, °C Default = °F

8.12 MODE 7 & 8: EXTERNAL TEMPERATURE TARGET OPERATION: VIEW DISPLAY

From the Home display;

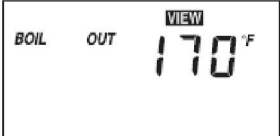
- 1) Press [ITEM] to view the following parameters:



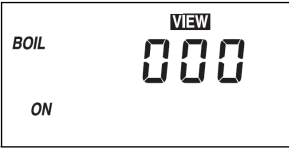
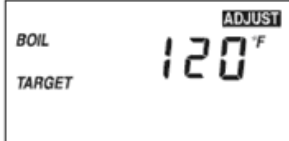



Display	Parameter Name	Parameter Description	Parameter Range
 The display shows "BOIL" on the left, "OUT" below it, a large "170" in the center, and "°F" on the right. "VIEW" is in a small box at the top right.	Boiler Outlet Temperature	Real-time Outlet Temperature to Boiler	14 to 266°F (-10 to 130°C)
 The display shows "BOIL" on the left, "IN" below it, a large "145" in the center, and "°F" on the right. "VIEW" is in a small box at the top right.	Boiler Inlet Temperature	Real-time Inlet Temperature to Boiler	14 to 266°F (-10 to 130°C)
 The display shows "BOIL" on the left, "ΔT" below it, a large "25" in the center, and "°F" on the right. "VIEW" is in a small box at the top right.	Boiler Delta T	Real-time temperature difference between the outlet sensor and the inlet sensor.	-99 to 252°F (-72 to 140°C)





	Total Run Time Since Installation	Monitors the amount of operational time since the unit was installed. The two digits are the thousands of hours and the three digit display shows the hundreds of hours. Press (▲, ▼) simultaneously to reset the counter	Alternates between 00 and 999
	Boiler Target Temperature	To provide a target setpoint for the heating system. Setpoint is controlled to the inlet sensor	OFF, 70 to 220°F (OFF, 21 to 104°C)

8.13 MODE 7 & 8: EXTERNAL TEMPERATURE TARGET OPERATION: ADJUST DISPLAY

From the Home display;

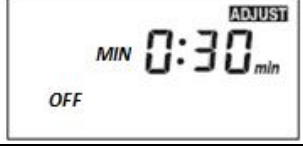
- 1) Press (Item, ▲, ▼) simultaneously to view the following parameters:

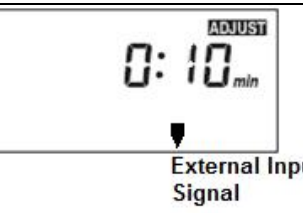
Display	Parameter Name	Parameter Description	Parameter Range
	Mode	Operating mode for the boiler.	1 to 8 Default = 1
	Boil Max	Maximum boiler target temperature	120 to 225°F (48 to 107°C) Default = 210°F (99°C)
	Boil Min	Minimum boiler target temperature	80 to 180°F (26 to 82°C) Default = 130°F (54°C)
	Differential Temperature	To start the boiler below the Boiler Target temperature. For example, if the value is 10°F and the Boiler Target is 160°F the boiler will begin to modulate at 150°F and shut off at 170°F.	Au, 2 to 42°F (Au, -17 to 5°C) Default = 10°F
	Stage Differential	Dictates the staging of the boiler and each stage is iterative. For example, if the value is 3°F. Stage 1 will be active 3°F below setpoint, Stage 1 & 2 will be active 6°F below setpoint.	Au, 2 to 42°F (Au, -17 to 6°C) Default = 10°F
	On Delay	Interstage delay to activate the next stage	0:10 to 8:00 minutes Default = 1:00 minute

	Minimum On Time	Minimum on time for each stage	0:10 to 5:00 minutes Default = 0:30 minute
	Minimum Off Time	Minimum off time for each stage	0:10 to 5:00 minutes Default = 0:50 minutes
	Pump Delay	Boiler post pump time after burner has shut off, in seconds.	OFF, 0:20 to 9:55 min, On Default = 1:00 min
	External Input Signal (Mode 8 ONLY)	Select the range for the external input signal that adjusts the boiler target.	0:10 or 2:10 Default = 0:10
	Offset (Mode 8 ONLY)	Select the amount of temperature offset to add to the boiler target calculated from the external input signal.	-10 to 10°F (-5 to 5°C) Default = 0°F
	Temperature Units	Select the desired unit of measurement	°F, °C Default = °F

9 OPERATION

The MicoFlame Grande appliance should be installed and started up by factory qualified personnel.

9.1 START-UP

Gas appliances are rated based on sea level operation with no adjustment required at elevations up to 2000 ft. At elevations above 2000 ft the input rating must be reduced by 4% for each additional 1000 ft elevation. Never increase the input of the appliance above that for which it is rated.

Pilot Pressure Setting

The pilot is preset at the factory. The following description is for the benefit of the start-up technician should minor adjustment be required. The pilot burner is controlled by a separate pilot valve. Pilot pressure setting is as shown in Table 7. A view port is provided on the appliance's return end to view the pilot and the main burners. If adjustment is necessary the following steps must be followed: Remove the lower front jacket panel; Remove the 1/8" plug from the elbow pressure tap and connect a manometer; Remove regulator adjustment screw cap from the pilot valve; Rotate the regulator adjustment screw clockwise to increase the manifold pressure or counter-clockwise to decrease it; Once satisfied replace the regulator adjustment screw cap and the elbow pressure tap plug.

Table 7 – Gas pressures at inlet to pilot

	PROPANE	NATURAL GAS
Minimum (inches W.C.)	3.9	3.5
Maximum (inches W.C.)	9.3	4.5

Pilot Flame Rectification Setting

The pilot flame rectification was preset at the factory. The following description is for the benefit of the start-up technician should minor adjustment be required. Set pilot to obtain best μA reading from flame rectification. Minimum average signal of 1.5 μA is required. If required, test the signal using a DC μA meter following this procedure for Honeywell S8600 ignition module: Disconnect ground wire at appliance transformer; Disconnect the 24V power and ground wires from all S8600 ignition modules

not being tested; Set meter to μA DC: Connect one of the meter's terminals to the burner ground terminal on the S8600 and the other terminal to the burner ground wire; Pilot running without main burner will generate 1.5 μA average for best operation. With main burner running, the signal will be in a range of 4.0 to 7.0 μA .

Gas Pressure Setting

The gas valve pressure regulator is preset at the factory. The following description is for the benefit of the start-up technician should minor adjustment be required.

Optimum results are obtained when the appliance is operated with manifold pressure as indicated on the rating plate. If adjustment is necessary the following steps must be followed (please refer to figure 16): Remove the lower front jacket panel; Remove the 1/8" plug from the elbow pressure tap and connect a manometer; Remove regulator adjustment screw cap from the combination valve; Rotate the regulator adjustment screw clockwise to increase the manifold pressure or counterclockwise to decrease it; Once satisfied replace the regulator adjustment screw cap and the elbow pressure tap plug.

Air Flow Setting

The fan inlet air shutter has been preset at the factory. The following description is for the benefit of the start-up technician should minor adjustment be required.

Optimum results are obtained when the appliance is operated with air box pressure as set in Table 11. If adjustment is necessary the following steps must be followed: Remove the lower front jacket panel; connect a manometer to the air pressure tap provided on the combustion chamber door; with the fan operating the air pressure should be set per Table 11 by adjusting the air inlet shutter on the fan inlet; To adjust the air shutter, first undo the securing nut and rotate the bolt so the shutter will open or close as required; At full input the CO_2 should be between 7.5% and 8.5% for natural gas and 1.5% higher for propane and the CO reading be less than 50 ppm. For a condensing appliance the CO_2 level shall be in the range of 8.5% to 9.0%. For Propane CO_2 level will be approximately 1.5% higher. Once satisfied tighten the nut on the fan's shutter bolt making sure it is secured.

Pressure Switch Settings

The switches have been preset at the factory as per Table 11. The following description is for the benefit of the start-up technician should minor adjustment be required.

Differential air pressure switches are provided to shut down the gas supply line under block flue condition. One pressure switch is provided per burner. If adjustment is necessary the following steps must be followed: Remove the lower front jacket panel; insert allen key into the switch located on the combustion chamber door; with the fan operating the switch should be set per Table 11 by rotating the allen key.

Ignition System Safety Shut-Off Device

After initial fill while the main burner is firing, shut off gas to the pilot and clock the time taken for the main gas valve to shut down. If the safety control is functioning properly, power to the gas valve will be shut off within 4 seconds of the pilot gas being shut off. If shut down takes longer, ignition control or gas valve may be defective. If shutdown does not occur it is possible that the main flow is generating a signal at the pilot in which case the pilot shall not recycle with the pilot gas off.

Appliances Start Up

With the appliance off, open makeup water valve and allow system to fill slowly. With all air vents open, run system circulating pump for a minimum of 30 minutes with the appliance off. Open all strainers in the circulating system and check for debris. Check liquid level in expansion tank. With system full of water at 15 PSIG cold, the level of water in the expansion tank should not exceed $\frac{1}{4}$ of the total volume with the balance filled with air. Start up appliance following instructions provided. Operate entire system including pumps and radiation for at least 1 hour. Check water level in expansion tank. If level exceeds $\frac{1}{2}$ of tank volume, air is still trapped in system. Shut down appliance and continue to run pumps. Within 3 days of start up, recheck all air vents and expansion tank as described above.

9.2 STAGING OPERATION

All MicoFlame Grande models are available as on/off, 2-stage, 3-stage and 4-stage. Model 2000 is provided with two burners. Models 2500 and 3000 are provided with three burners and models 3500 and 4000 are provided with four burners. Each burner is supplied with a dedicated airflow proving signal and separate proved pilot ignition system. All fans must be running in order for the appliance to proceed to trial for ignition.

Each MicoFlame Grande is supplied with the appropriate wiring diagram showing the actual staging sequence provided as well as any special controls or options requested. When converting multiple MicoFlame Grande appliances to an external sequencing control it is absolutely necessary to program the sequencer properly by entering the number of stages provided on the appliance. In this way the sequencer will lead/lag or rotate the appliances properly.

A full diagnostics panel is provided on the MicoFlame Grande. On a call for heat, status lights will light up if the particular safety is working properly. Once all safeties have been proved, the appliance will proceed to trial for ignition and will then sequentially bring on the burner stages (and the corresponding lights). If the safety proving sequence does not proceed to completion, the first safety light to remain off will indicate the cause of the problem. All other lights below the problem indicator light will also remain off.

Burner staging is arranged to allow a minimum firing rate of no less than 50% in order to minimize possibility of condensation in the venting and provide even heat distribution over the heat exchanger. Staging options are as follows:

Table 8 – Firing Modes Model 2000 (Two Burners)

		Burner 1	Burner 2
Two Stages	Stage 1	Low Fire	Low Fire
	Stage 2	High Fire	High Fire
Three Stages	Stage 1	Low Fire	Low Fire
	Stage 2	High Fire	Low Fire
	Stage 3	High Fire	High Fire
Four Stages	Stage 1	Low Fire	Low Fire
	Stage 2	Low Fire	Low Fire
	Stage 3	High Fire	Low Fire
	Stage 4	High Fire	High Fire

Table 9 – Firing Modes Model 2500 and 3000 (Three Burners)

		Burner 1	Burner 2	Burner 3
Two Stages	Stage 1	Low Fire	Low Fire	Low Fire
	Stage 2	High Fire	High Fire	High Fire
Three Stages	Stage 1	Low Fire	Low Fire	Low Fire
	Stage 2	High Fire	Low Fire	Low Fire
	Stage 3	High Fire	High Fire	High Fire
Four Stages	Stage 1	Low Fire	Low Fire	Low Fire
	Stage 2	High Fire	Low Fire	Low Fire
	Stage 3	High Fire	High Fire	Low Fire
	Stage 4	High Fire	High Fire	High Fire

Table 10 – Firing Modes Model 3500 and 4000 (Four Burners)

		Burner 1	Burner 2	Burner 3	Burner 4
Two Stages	Stage 1	Low Fire	Low Fire	Low Fire	Low Fire
	Stage 2	High Fire	High Fire	High Fire	High Fire
Three Stages	Stage 1	Low Fire	Low Fire	Low Fire	Low Fire
	Stage 2	High Fire	High Fire	Low Fire	Low Fire
	Stage 3	High Fire	High Fire	High Fire	High Fire
Four Stages	Stage 1	Low Fire	Low Fire	Low Fire	Low Fire
	Stage 2	High Fire	High Fire	Low Fire	Low Fire
	Stage 3	High Fire	High Fire	High Fire	Low Fire
	Stage 4	High Fire	High Fire	High Fire	High Fire

9.3 OPERATION SEQUENCE

POWER ON

Demand for heat

BTC Staging control 30 seconds count down before energizing the first stage. Next the stage switch closes.

Pre-purge

Fan manager energizes starting 15 seconds of pre-purge cycle.

Ignition Trial

On proof of air flow, the air proving switch closes and energizes the ignition module. The module first initiates a self check and then starts the pilot ignition sequence. The safety shutoff valve opens, which allows gas to flow to the pilot burner. At the same time, the electronic spark generator in the module produces 10,000 Volt spark pulse output. The voltage generates a spark at the igniter that ignites the pilot. If the pilot does not light, or the pilot flame current is not at least, on average, 1.5 μ A and steady, the module will not energize the combination valve and the main burner will not light. The ignition module provides 100% gas shutoff, followed by retry for ignition. If required (e.g. CSD1) a module with lockout feature can be provided.

Main Burner

When the pilot flame is established, a flame rectification circuit is completed between the sensor and the burner ground. The flame sensing circuit in the ignition module detects the flame current, shuts off the spark generator and energizes the combination valve operator. The combination valve opens and gas flows to the main burner, where it is ignited by the pilot burner. On the lock out ignition module, the flame current also holds the safety lockout timer in the reset operating condition. When the call for heat ends, both valve operators are de-energized, and both valves in the gas control close.

Normal Operation

Staging is controlled from the Boiler Temperature Controller (BTC). The BTC operates the boiler stages to maintain the target temperature.

Demand Satisfied

Boiler Temperature Controller senses that the boiler target temperature was reached and de-energizes the stage 1 contact.

Staging Control Alarms

High limit or low water flow will de-energize all gas valves, and the blower. Condition indicators are visible on the control panel. Each burner/blower set is provided with its own air pressure switch. If a low air pressure condition is present, power will not be supplied to the ignition module. The blower will remain on and the air indicator will remain on for as long as there is a call for heat.

10 PILOT AND MAIN BURNER FLAMES

10.1. MAIN BURNER

The main burner, figure 14 should display the following characteristics;

- Acceptable CO and CO₂ levels for complete combustion.
- Light off smoothly.
- Reasonably quiet while running.
- Stable flame with minimum of lifting.
- Blue flame with natural gas, yellow tips with propane gas

Figure 14 - Burner

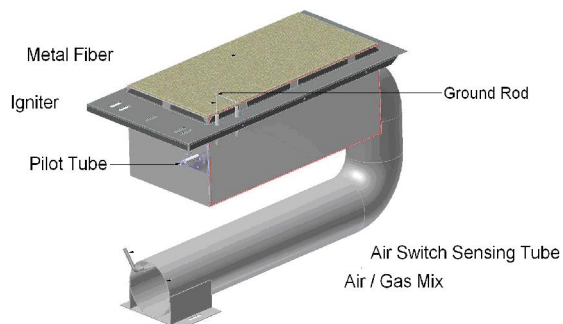

If burner characteristics do not match the above, check for proper air box pressure. Look for accumulation of lint and other foreign material at fan air inlets.

Table 11 – Typical air box settings

MODEL	AIR BOX " W.C. (with burner firing)			
	Burner #1	Burner #2	Burner #3	Burner #4
2000	1.9 (2.2)	1.9 (2.2)		
2500	1.5 (1.8)	1.5 (1.8)	1.5 (1.8)	
3000	1.9 (2.2)	1.9 (2.2)	1.9 (2.2)	
3500	1.6 (1.9)	1.6 (1.9)	1.6 (1.9)	1.6 (1.9)
4000	1.9 (2.2)	1.9 (2.2)	1.9 (2.2)	1.9 (2.2)
MODEL	FLUE SWITCH RECYCLE POINT " W.C			
	Burner #1	Burner #2	Burner #3	Burner #4
2000	1.5 (1.9)	1.5 (1.9)		
2500	1.1 (1.5)	1.1 (1.5)	1.1 (1.5)	
3000	1.5 (1.9)	1.5 (1.9)	1.5 (1.9)	
3500	1.2 (1.6)	1.2 (1.6)	1.2 (1.6)	1.2 (1.6)
4000	1.5 (1.9)	1.5 (1.9)	1.5 (1.9)	1.5 (1.9)

Depending on field conditions air box pressures will have to be adjusted accordingly. Always set the appliance for a CO₂ level in the range of 7.5% to 8.5 %. For a condensing appliance the CO₂ level shall be in the range of 8.5% to 9.0%. For Propane CO₂ level will be approximately 1.5% higher.

A qualified service technician should follow this procedure when burner needs cleaning.

1. Shut off power and close main manual gas valve.
 - Allow burner to cool before removal.
2. Remove access cover screws.
 - Disconnect pilot gas at bulkhead fitting.
 - Disconnect ground wire and ignition wire.
 - Remove nuts holding down burner.
 - Gently pull down and forward to disengage burner.

- Remove burner being careful to not damage the igniter or ground electrodes.
3. Thoroughly clean burner using water or air. Check all ports and air channels for blockage.
 4. Reinstall the burner being careful to fully engage the back of the burner box into the retaining slot in the combustion chamber base. Failure to properly locate the burner will result in erratic flame operation with the possibility of delayed ignition on light off.
 5. Restore electrical power and gas supply to the appliance.
 - Following the lighting instructions put the appliance back into operation
 - Check for gas leaks and proper appliance and vent operation.

10.2. PILOT BURNER

Turn the pilot firing valve to off position and allow the appliance to try for ignition. Observe the spark making sure that it is strong and continuous.

If the spark is not acceptable the igniter will have to be adjusted. This can be readily accomplished after removing the main burner.

The spark gap should be 1/8" to 3/16" between igniter and ground rod and 3/8" between igniter and surface of metal fiber. Make sure that the electrode does not appear overheated or fouled with carbon. It may be necessary to clean the ignition electrode using steel wool. Once the pilot appears to be properly set, reinstall it into the appliance making sure to properly tighten the pilot line connection.

If the pilot is removed from the main burner in the course of servicing the appliance, it is important to reinstall it so that there is no gap between the top surface of the pilot tube and the underside of the metal filter support screen. When properly set it will not be possible to slip a business card between the pilot burner and the support screen. Figure 15 shows the burner box assembly with the metal filter cover removed to expose pilot tube.

Figure 15 – Pilot and Burner Box

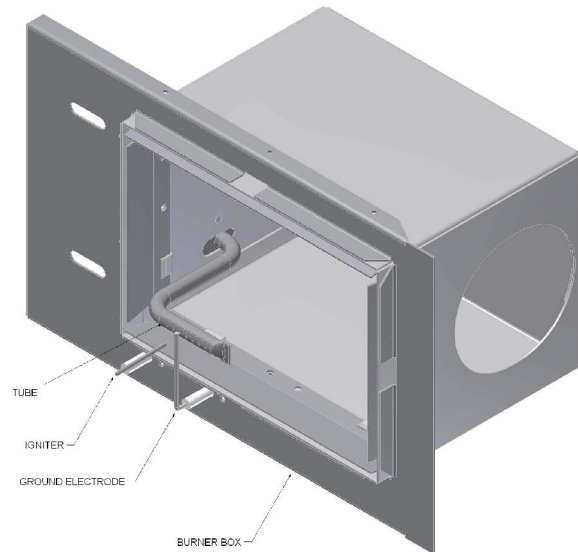

Once the spark is satisfactory, open the pilot gas and allow the pilot burner to light. Once air has been purged from the pilot line, the pilot flame should appear almost instantly at the initiation of spark. Cycle the pilot several times to confirm reliability. A properly set pilot will appear blue and will engulf the igniter and ground electrode.

Open the firing valve and allow the main burner to light. The pilot must not extinguish. After running for 15 minutes, cycle the appliance to ensure that the pilot remains stable.

11 OPERATION AND SERVICE

OPERATION:

Before operating the appliance, the entire system must be filled with water, purged of air and checked for leaks. Do not use Stop leak or other appliance compounds. The gas piping must also be leak tested.

With the boiler off, open makeup water valve and allow system to fill slowly. Adjust the pressure regulator to provide at least 15 PSIG in the system when cold.

With all air vents open, run system circulating pump for a minimum of 30 minutes with the boiler off.

Open all strainers in the circulating system and check for debris.

Check liquid level in expansion tank. With system full of water at 15 PSIG, the level of water in the expansion tank should not exceed $\frac{1}{4}$ of the total volume with the balance filled with air.

Start up boiler following instructions provided. Operate entire system including pumps and radiation for at least 1 hour. Minimum operating system pressure when hot must not drop below 30 PSIG.

Check water level in expansion tank. If level exceeds $\frac{1}{2}$ of tank volume, air is still trapped in system. Shut down boiler and continue to run pumps.

Within 3 days of start up, recheck all air vents and expansion tank as described above.

Any safety devices including low water cutoff, flow switch and high limit used in with this appliance must receive periodic inspection (every six months) to assure proper operation. A low water cutoff of the float type should be flushed every six months. All relief valves should be inspected and manually operated every six months.

For your safety follow the lighting and operating instructions below and on the appliance.

To turn on main burner, slowly open firing valve after pilot is established.

Set primary system controller to desired temperature.

To turn off appliance close main manual gas valve, close pilot manual valve and turn off electric power to system.

SERVICE:

To maintain safe operation and the greatest efficiency of the appliance, check the main burner and pilot burner for proper flame characteristics.

For hydronic heating applications the burner should be checked at least yearly. For domestic hot water applications the burner should be checked every 6 (six) months.

Disconnect main power and turn off gas supply before servicing unit.

To remove and clean the burner, follow the detailed procedure in section 10.1 of this manual

After the first season of operation inspect the heat exchanger and venting. Follow the detailed instructions in section 7 of this manual.

CAUTION: Label all wires prior to disconnection when servicing controls. Wiring errors can cause improper and dangerous operation. Verify proper operation after servicing.

Any audible sounds in the equipment, like pinging, crackling or hissing are indications of scaling or lack of sufficient water flow. Under these conditions the appliance must be shut down immediately and the heat exchanger checked for damage. If the exchanger is damaged from improper installation or operation, it is not covered by warranty.

Should your equipment be subjected to fire, flood or some other unusual condition, turn off all gas and electrical supply. If you are unable to turn off the gas, call your gas company or gas supplier at once. Do not put the unit back in operation until it has been checked by a qualified service technician.

Units that are not operated for a period of 60 days or more are considered seasonal operations. It is recommended that before returning one of these units to service, the proper operation of all controls be checked by a qualified service technician.

12 LIGHTING INSTRUCTIONS

1. Turn off electric power to appliance.
2. Close main manual valve and main firing valve and wait 5 minutes.
3. Set primary system controller to desired temperature.
4. Open pilot valve.
5. Turn on electric power to appliance. The electrode at the pilot should begin to spark after pre-purge is complete. The pilot valve will open to permit gas flow to the pilot.
6. There is a 15 second trial for ignition, which is enough time to light the pilot if air is not present in the pilot line. If pilot fails to light and you suspect air in the

line, close the main manual valve and repeat lighting steps 1 thru 5.

7. Once the pilot lights, it should envelope the ignition rod and ground electrode. The pilot can be adjusted by removing the pilot regulator cover and turning the adjustment screw counter clockwise to increase it or clockwise to decrease it.
8. Open the main manual and main firing valves to allow gas to reach the main burner. If the main burner fails to ignite, turn the firing valve off and check to see that the pilot is burning. If not, repeat lighting procedure steps 1 thru 7.

TO TURN OFF APPLIANCE: Close main manual valve and main firing valve and turn off electric power to system.

13 TROUBLE SHOOTING GUIDE

SYMPTOM	SOLUTION
1. Power light is not lit when switch is flipped to "ON"	<ul style="list-style-type: none"> • Check wiring to switch. • Activate push button for latch relay if provided. • Check circuit breaker. • Check fuse.
2. Water flow light remains off.	<ul style="list-style-type: none"> • Verify that pump is running. • Check wiring to flow switch.
3. Pilot sparks but does not light	<ul style="list-style-type: none"> • Verify that main manual valve is open. • Follow lighting instructions to bleed air out of pilot line. • Remove main burner and inspect for moisture or dirt in pilot or in pilot line. • Verify that pilot is sealed to main burner base. • Verify that gas connections are tight.
4. Pilot lights momentarily, goes out and then sparks again repeatedly	<ul style="list-style-type: none"> • Observe pilot for proper flame. Adjust if necessary. • Check pilot flame signal. Properly set pilot to generate 1.5 μA. D.C. on average. • Remove main burner and ensure that igniter and ground electrodes are positioned properly. Clean with steel wool if necessary. • Verify that back of burner box is fully engaged into the retaining slot in the combustion chamber base.
5. Pilot lights but main burner does not fire.	<ul style="list-style-type: none"> • Verify that main manual valve is in "ON" position. • Check wiring to valve from ignition control.
6. Main burner lights but cycles off after a few minutes	<ul style="list-style-type: none"> • Verify that high limit is set high enough to prevent short cycling. • Check pilot flame signal (μA). • Adjust pilot pressure for steady flame • Remove main burner. Check position of igniter and ground electrode. Clean with steel wool if necessary.
7. Appliance starts to whine as the temperature rise increases.	<ul style="list-style-type: none"> • Verify that all air is bled from system. • Verify that the static pressure in cold system is at least 15 psig. • At system operating temperature static pressure must be no less than 30 PSIG. • Check temperature rise across appliance to ensure adequate water flow. • If necessary, increase static water pressure and decrease gas pressure.

14 TYPICAL GAS TRAIN

Figure 16 – Gas Train

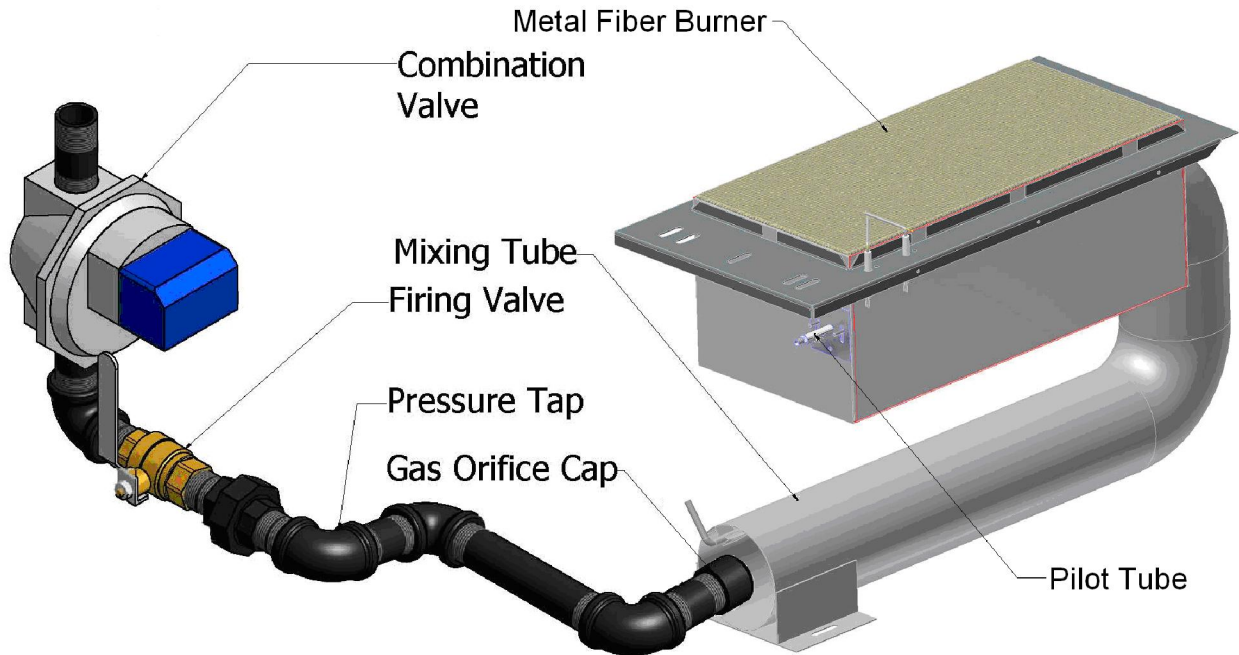

15 ELECTRICAL DIAGRAMS

Each MicoFlame Grande appliance will be provided with its own wiring diagram to guarantee that any options ordered with the unit are properly detailed.

The following diagrams 99-5082-1 and 99-5082 are provided as typical samples only.

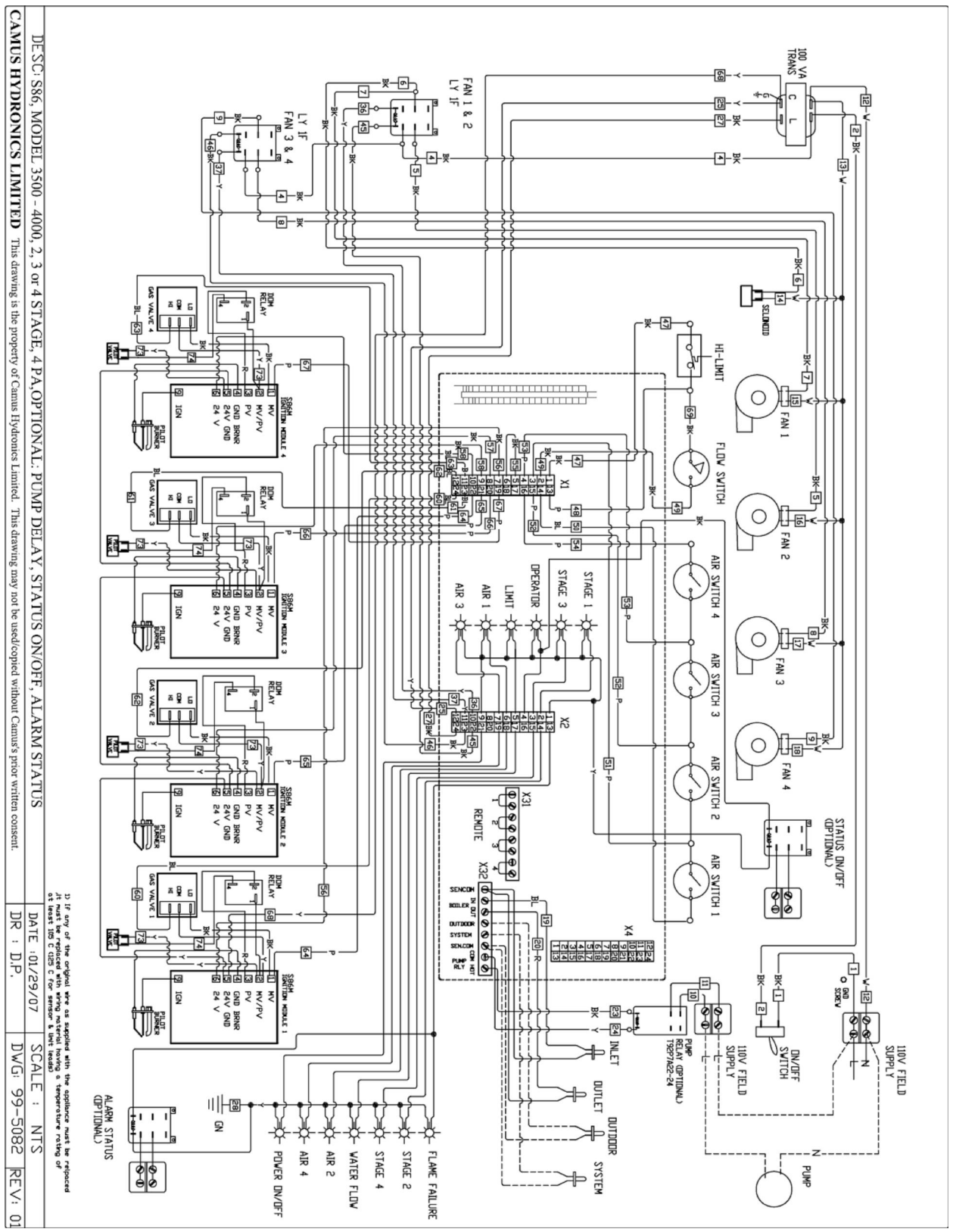

DESC: S86, MODEL 3500 - 4000, 2, 3 or 4 STAGE, 4 PA, OPTIONAL: PUMP DELAY, STATUS ON/OFF, ALARM STATUS
CAMUS HYDRONICS LIMITED This drawing is the property of Camus Hydronics Limited. This drawing may not be used/copied without Camus's prior written consent.

DR : D.P.	SCALE : NTS	REV: 01
DATE : 01/29/07	DWG: 99-5082	

1) If any of the original wire as supplied with the appliance must be replaced
 2) It must be replaced with wire of material having a temperature rating of
 at least 100 C (200 F) for sensor & limit leads

16 EXPLODED VIEW MicoFlame Grande

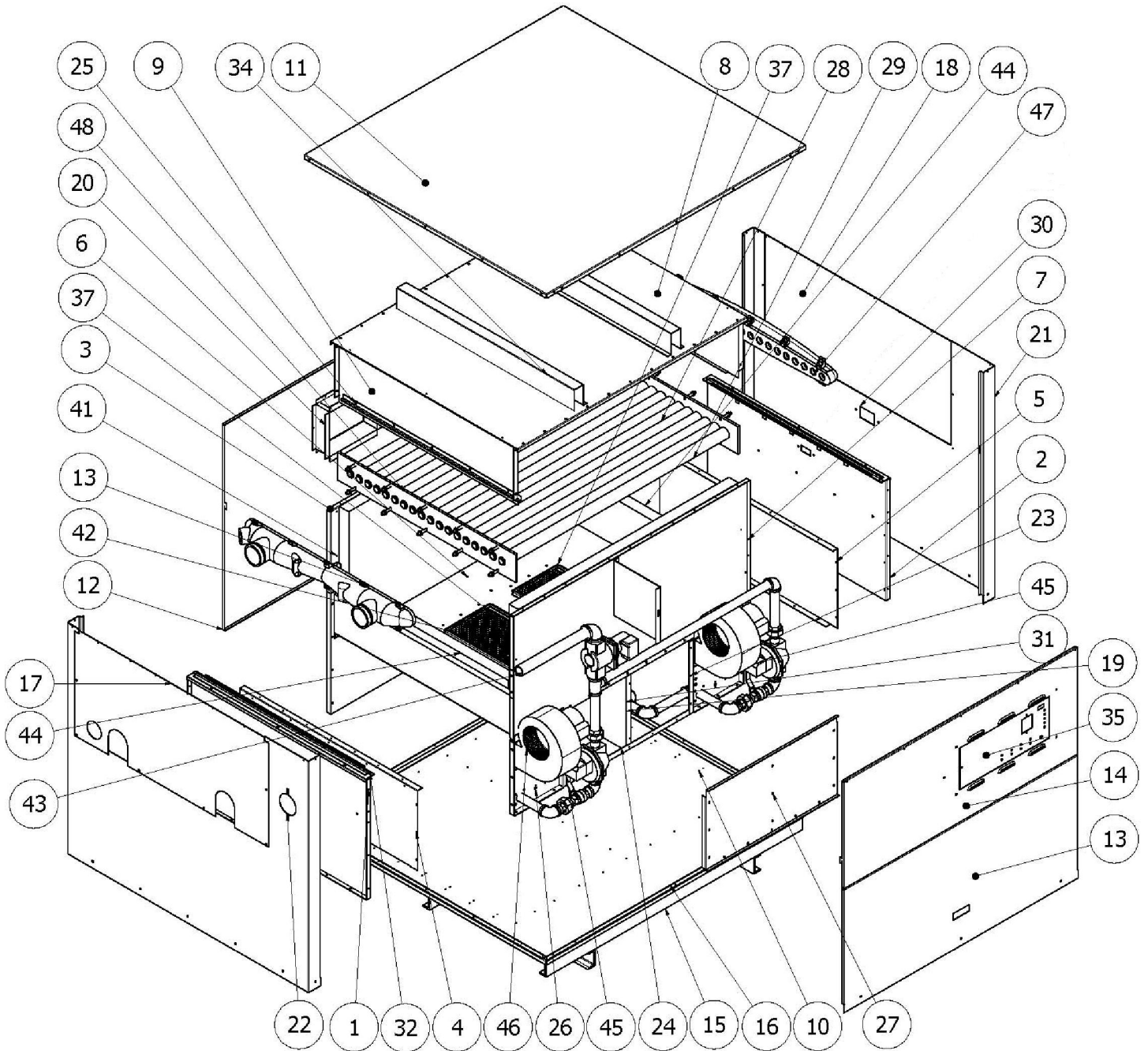

17 EXPLODED VIEW MicoFlame Grande Outdoor and/or Condensing

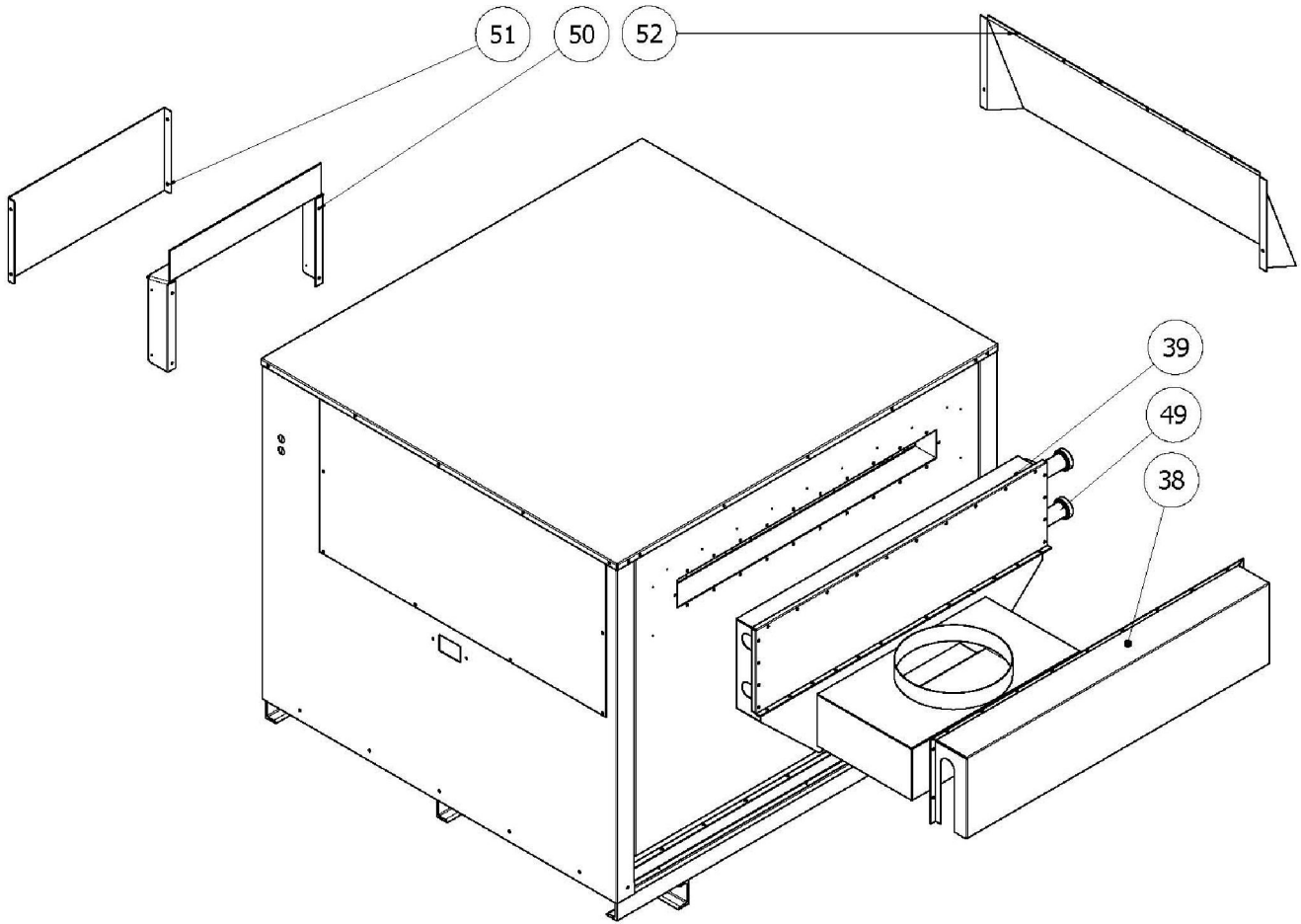

18 MICROFLAME GRANDE REPLACEMENT PARTS LIST

Ref #	Part Name	Model Number				
		2010	2500	3000	3500	4000
1	Combustion Chamber End Panel - Left	14-4200	14-4 200	14-4200	14-4200	14-4200
2	Combustion Chamber End Panel - Right	14-4201	14-4201	14-4201	14-4201	14-4201
3	Combustion Chamber Rear Panel	14-4202-20	14-4202-30	14-4202-30	14-4202-40	14-4202-40
4	Combustion Chamber Support - Left	14-4203	14-4203	14-4203	14-4203	14-4203
5	Combustion Chamber Support - Right	14-4204	14-4204	14-4204	14-4204	14-4204
6	Combustion Chamber Base	14-4205-20	14-4205-30	14-4205-30	14-4205-40	14-4205-40
7	Combustion Chamber Upper Front	14-4206-20	14-4206-30	14-4206-30	14-4206-40	14-4206-40
8	Flue Collector Top	14-4207-20	14-4207-30	14-4207-30	14-4207-40	14-4207-40
9	Flue Collector End Bracket	14-4208	14-4208	14-4208	14-4208	14-4208
10	Base Panel	14-4209-20	14-4209-30	14-4209-30	14-4209-40	14-4209-40
11	Outer Jacket Top Cover	14-4210-20	14-4210-30	14-4210-30	14-4210-40	14-4210-40
12	Outer Jacket Back Panel	14-4211-20	14-4211-30	14-4211-30	14-4211-40	14-4211-40
13	Outer Jacket Front Lower Panel	14-4212-20	14-4212-30	14-4212-30	14-4212-40	14-4212-40
14	Outer Jacket Front Upper Panel	14-4213-20	14-4213-30	14-4213-30	14-4213-40	14-4213-40
15	Base Support Weldment	16-4214-20	16-4214-30	16-4214-30	16-4214-40	16-4214-40
16	Base Panel Lips	14-4215-20	14-4215-30	14-4215-30	14-4215-40	14-4215-40
17	Inlet Outlet Side Access Panel	14-4216	14-4216	14-4216	14-4216	14-4216
18	Return Side Access Panel	14-4217	14-4217	14-4217	14-4217	14-4217
19	Combustion Chamber Centre Divider	N/A	N/A	N/A	14-4218	14-4218
20	Flue Collector Outlet	14-4219-20	14-4219-30	14-4219-30	14-4219-40	14-4219-40
21	Outer Jacket Side Panel - Right	14-4231	14-4231	14-4231	14-4231	14-4231

Ref #	Part Name	Model Number				
		2010	2500	3000	3500	4000
22	Outer Jacket Side Panel - Left	14-4232	14-4232	14-4232	14-4232	14-4232
23	Fan Mounting Support - Right	14-4233	14-4233	14-4233	14-4233	14-4233
24	Burner Door Stop	14-4234	14-4234	14-4234	14-4234	14-4234
25	Heat Exchanger Header Stop Bar	14-4238	14-4238	14-4238	14-4238	14-4238
26	Fan Mounting Support - Left	14-4239	14-4239	14-4239	14-4239	14-4239
27	Burner Door	14-4240	14-4240	14-4240	14-4240	14-4240
28	V Baffles	14-4241-20	14-4241-30	14-4241-30	14-4241-40	14-4241-40
29	HX Front and Back Baffles	14-4242-20	14-4242-30	14-4242-30	14-4242-40	14-4242-40
30	Sight Glass Assembly	MF Sightglass				
31	Outer Jacket Door Jam	N/A	N/A	N/A	14-4252	14-4252
32	Heat Exchanger Support Weldment	14-4253	14-4253	14-4253	14-4253	14-4253
34	Outer Jacket Top Panel Support	14-4255	14-4255	14-4255	14-4255	14-4255
35	Control Panel Assembly	14-4160	14-4160	14-4160	14-4160	14-4160
37	Three Tiles Burner Box Assembly	14-4225	14-4225	14-4225	14-4225	14-4225
38	Economizer Cover*	14-4146	14-4265-01	14-4265-01	14-4265-01	14-4265-01
39	Economizer Assembly*	14-4148-03	14-4266-01	14-4266-01	14-4266-01	14-4266-01
40	Front Refractory	17-0084-01	17-0084-02	17-0084-02	17-0084-03	17-0084-03
41	Rear Refractory	17-0085-01	17-0085-02	17-0085-02	17-0085-03	17-0085-03
42	Inlet Outlet Header	13-0040	13-0040	13-0040	13-0040	13-0040
43	Gas Train	-	-	-	-	-
44	Common End Refractory	17-0083	17-0083	17-0083	17-0083	17-0083
45	Gas Train	-	-	-	-	-
46	Fan	55-0001				
47	Return Header	13-0041	13-0041	13-0041	13-0041	13-0041
48	Primary Heat Exchanger	15-0195-01	15-0195-02	15-0195-02	15-0195-03	15-0195-03
49	Economizer	CAM-2000	CAM-4000	CAM-4000	CAM-4000	CAM-4000
50	Control Panel Outdoor Cover**	14-4245	14-4245	14-4245	14-4245	14-4245
51	Control Panel Outdoor Cover Door**	14-4246	14-4246	14-4246	14-4246	14-4246

Ref #	Part Name	Model Number				
		2010	2500	3000	3500	4000
52	Inlet Outlet Header Outdoor Cover**	14-4247	14-4247	14-4247	14-4247	14-4247
53	Air Inlet Filter	12"	14"		16"	
54	Heat Exchanger	MFG-2000-HTX	MFG-2500-HTX	MFG-3000-HTX	MFG-3500-HTX	MFG-4000-HTX
55	Air Switch	IS20105-5762A				
56	Ignition Module – Continuous Retry	S8610M3017				
57	Ignition Module – Single Try	S8600H3010				
58	Pilot Valve/Combination Valve	CV100B6N-22-0001				

* Condensing Models Only

** Outdoor Models Only

 Not Shown in Exploded View

WARRANTY

GENERAL

Camus Hydronics Limited ("Camus"), extends the following LIMITED WARRANTY to the owner of this appliance, provided that the product has been installed and operated in accordance with the Installation Manual provided with the equipment. Camus will furnish a replacement for, or at Camus option repair, any part that within the period specified below, shall fail in normal use and service at its original installation location due to any defect in workmanship, material or design. The repaired or replacement part will be warranted for only the unexpired portion of the original warranty. This warranty does not cover failures or malfunctions resulting from: (1) Failure to properly install, operate or maintain the equipment in accordance with Camus' manual; (2) Abuse, alteration, accident, fire, flood, foundation problems and the like; (3) Sediment or lime buildup, freezing, or other conditions causing inadequate water circulation; (4) Pitting and erosion caused by high water velocity; (5) Failure of connected systems devices, such as pump or controller; (6) Use of non-factory authorized accessories or other components in conjunction with the system; (7) failing to eliminate air from, or replenish water in, the connected water system; (8) Chemical contamination of combustion air or use of chemical additives to water.

HEAT EXCHANGER

If within TEN years after initial installation of the appliance, a heat exchanger, shall prove upon examination by Camus to be defective in material or workmanship, Camus will exchange or repair such part or portion on the following pro rated limited warranty. (1) Years one through five - standard warranty (2) Years six through ten - replacement purchase price pro rated at the following schedule: Year six - 60%, Year seven - 65%, Year eight -70%, Year nine -75% Year ten -80% of the current list price of the current list price This term is reduced to FIVE years if the appliance is used for other than hydronic space heating.

Heat Exchanger shall be warranted for (20) years from date of installation against "Thermal Shock" (excluded, however, if caused by appliance operation at large changes exceeding 150 °F between the water temperature at intake and appliance temperature, or operating at appliance temperatures exceeding 230 °F).

BURNER

If within FIVE years after initial installation of the appliance a burner shall prove upon examination by Camus to be defective in material or workmanship, Camus will exchange or repair such part or portion.

ANY OTHER PART

If any other part fails within one (1) year after installation, or eighteen (18) months from date of factory shipment based on Camus' records, whichever comes first. Camus will furnish a replacement or repair that part. Replacement parts will be shipped f.o.b. our factory.

HOW TO MAKE A CLAIM

Any claim under this warranty shall be made directly to Camus Hydronics Limited Canadian Head Office

SERVICE LABOR RESPONSIBILITY

Camus shall not be responsible for any labour expenses to service, repair or replace the components supplied. Such costs are the responsibility of the owner.

DISCLAIMERS

Camus shall not be responsible for any water damage. Provisions should be made that in the event of a water/appliance or fitting leak, the resulting flow of water will not cause damage to its surroundings.

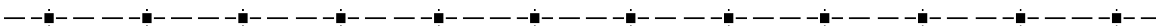

Name of Owner _____ Name of Dealer _____

Address _____ Address _____

Model No. _____ Serial No. _____

Date of Installation: _____ Date of Initial Operation: _____

[6226 Netherhart Road, Mississauga, Ontario, L5T 1B7, CANADA](#)

CAMUS Hydronics is a manufacturer of replacement parts for most copper finned

The CAMUS CERTIFIED! Seal assures you that Reliability, Efficiency & serviceability are built

water heaters and heating boilers as well as a

into every single unit! For more information



supplier of specialty HVAC products. Our service line is open 24 hours, 7 days a week!

on our innovative products from CAMUS Hydronics Limited, call 905-696-7800 today.



**CAMUS HYDRONICS LTD.
6226 Netherhart Road, Mississauga, Ontario L5T 1B7
TEL: 905-696-7800 FAX: 905-696-8801**